

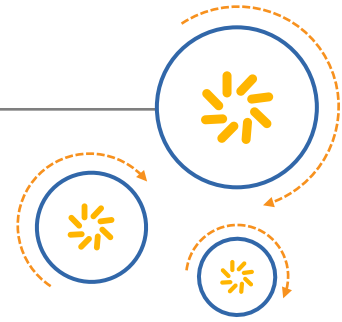

Qualcomm Technologies, Inc.



# WHS9410/WHS9420 (1.0) Evaluation Board

## Reference Schematic

80-PB443-42 Rev. A

June 29, 2017

For additional information or to submit technical questions, go to: <https://createpoint.qti.qualcomm.com>

**Confidential and Proprietary – Qualcomm Technologies, Inc.**

**NO PUBLIC DISCLOSURE PERMITTED:** Please report postings of this document on public servers or websites to: [DocCtrlAgent@qualcomm.com](mailto:DocCtrlAgent@qualcomm.com).

**Restricted Distribution:** Not to be distributed to anyone who is not an employee of either Qualcomm Technologies, Inc. or its affiliated companies without the express approval of Qualcomm Configuration Management.

Not to be used, copied, reproduced, or modified in whole or in part, nor its contents revealed in any manner to others without the express written permission of Qualcomm Technologies, Inc.

Qualcomm is a trademark of Qualcomm Incorporated, registered in the United States and other countries. Other product and brand names may be trademarks or registered trademarks of their respective owners.

This technical data may be subject to U.S. and international export, re-export, or transfer (“export”) laws. Diversion contrary to U.S. and international law is strictly prohibited.

Qualcomm Technologies, Inc.  
5775 Morehouse Drive  
San Diego, CA 92121  
U.S.A.

© 2017 Qualcomm Technologies, Inc. All rights reserved.

## Revision history

Revision	Date	Description
A	June 2017	Initial release

Qualcomm  
2018-05-08 18:01:25 PDT  
husion.zhao@aitgroup.com.cn

# 1 Reference schematic

## 1.1 Introduction

This document includes the placement, schematic, and a parts list of the WHS9410 or WHS9420 (1.0 hardware) evaluation board. The placement, schematic, and parts list included in this document are preliminary and are intended only as a reference. The placement diagram may include other components that are not shown in the schematic because they are solely used for Qualcomm Technologies, Inc. (QTI) internal test, development requirements, or any future expansion of the hardware board.

## 1.2 References

**Table 1** lists the QTI WHS9410 and WHS9420 device specification documents used in this reference design.

**Table 1 Reference documents**

QTI component	Document title	DCN
WHS9410	<i>WHS9410 USB Interface Audio Codec Device Specification (Advance Information)</i>	80-PB269-1
WHS9420	<i>WHS9420 USB Interface Audio Codec Device Specification (Advance Information)</i>	80-PB443-1

## 1.3 Schematic

This schematic is subject to change without notice and is not optimized for production products due to its conservative design approach and QTI internal test requirements. The component placements are shown on the first few sheets.





CONFIDENTIAL AND PROPRIETARY - QUALCOMM TECHNOLOGIES, INC.  
 COPYRIGHT (C) 2017 QUALCOMM TECHNOLOGIES, INC. ALL RIGHTS RESERVED.  
 NOT TO BE USED, COPIED, REPRODUCED, OR MODIFIED IN WHOLE OR IN PART, NOR  
 ITS CONTENTS REVEALED IN ANY MANNER TO OTHERS WITHOUT THE EXPRESS WRITTEN  
 PERMISSION OF QUALCOMM TECHNOLOGIES, INC.

THIS TECHNICAL DATA MAY BE SUBJECT TO U.S. AND INTERNATIONAL EXPORT,  
 RE-EXPORT, OR TRANSFER ("EXPORT") LAWS. DIVERSION CONTRARY TO U.S. AND  
 INTERNATIONAL LAW IS STRICTLY PROHIBITED.

QUALCOMM IS A TRADEMARK OF QUALCOMM INCORPORATED, REGISTERED IN THE  
 UNITED STATES AND OTHER COUNTRIES. OTHER PRODUCT AND BRAND NAMES MAY BE  
 TRADEMARKS OR REGISTERED TRADEMARKS OF THEIR RESPECTIVE OWNERS.

REVISIONS			
REV	DESCRIPTION	DATE	APPROVED
A	INITIAL RELEASE	----	----

# WHS9410/WHS9420 (1.0) EVALUATION BOARD



CONTRACT NO.		QUALCOMM TECHNOLOGIES, INC.		
DRAWN BY	DATE	TITLE SCHEMATIC, WHS9410/WHS9420 (1.0) EVALUATION BOARD SCHEMATIC		
ENGINEER	06-26-2017			
PROJECT ENGINEER				
QUALITY ASSURANCE				
CONFIGURATION		SIZE	DRAWING NO	REV
DESIGN ACTIVITY APPROVAL		D	80-PB443-42	A
DESIGN APPROVAL		SCALE NONE	RELEASE DATE	SHEET 1 OF 12

Title

8

7

6

5

4

3

2

1

CONFIDENTIAL AND PROPRIETARY - QUALCOMM TECHNOLOGIES, INC.  
 NOT TO BE USED, COPIED, REPRODUCED, OR MODIFIED IN WHOLE OR IN PART, NOR  
 ITS CONTENTS REVEALED IN ANY MANNER TO OTHERS WITHOUT THE EXPRESS WRITTEN  
 PERMISSION OF QUALCOMM TECHNOLOGIES, INC.  
 THIS TECHNICAL DATA MAY BE SUBJECT TO U.S. AND INTERNATIONAL EXPORT,  
 RE-EXPORT, OR TRANSFER ("EXPORT") LAWS. DIVERSION CONTRARY TO U.S. AND  
 INTERNATIONAL LAW IS STRICTLY PROHIBITED.

REVISIONS			
LTR	DESCRIPTION	DATE	APPROVED
A	INITIAL RELEASE		

D

SHEET	BLOCK	SCHEMATIC	SHEET	BLOCK	SCHEMATIC	SHEET	BLOCK	SCHEMATIC	SHEET	BLOCK	SCHEMATIC
1	\	TITLE									
2	\	TABLE OF CONTENTS									
3	\	USB-C CONNECTORS									
4	\	BOARD POWER									
5	\	WHS9410/WHS9420 DEVICE									
6	\	SPI NOR FLASH									
7	\	JTAG DEBUG CONNECTORS									
8	\	GPIO BUTTONS									
9	\	AUDIO JACKS									
10	\	LEDS									
11	\	MODE DIP SWITCHES									
12	\	DIGITAL CONFIG									

D

C

C

B

B

A

A

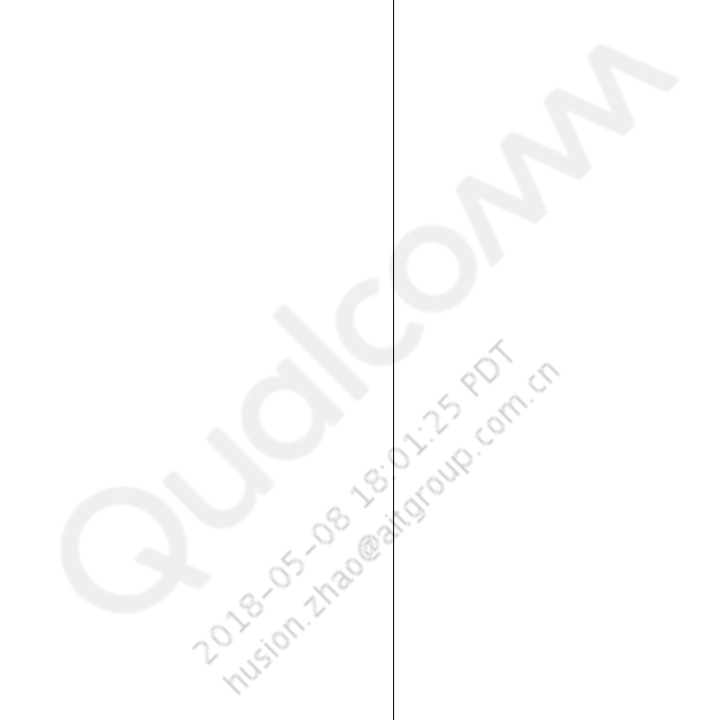

# TABLE OF CONTENTS

SIZE	D	DRAWING NO	80-PB443-42	REV	A
SCALE	NONE	SHEET	2	OF	12

8

7

6

5

4

3

2

1

7

CONFIDENTIAL AND PROPRIETARY - QUALCOMM TECHNOLOGIES, INC.  
 NOT TO BE USED, COPIED, REPRODUCED, OR MODIFIED IN WHOLE OR IN PART, NOR  
 ITS CONTENTS REVEALED IN ANY MANNER TO OTHERS WITHOUT THE EXPRESS WRITTEN  
 PERMISSION OF QUALCOMM TECHNOLOGIES, INC.

THIS TECHNICAL DATA MAY BE SUBJECT TO U.S. AND INTERNATIONAL EXPORT,  
 RE-EXPORT, OR TRANSFER ("EXPORT") LAWS. DIVERSION CONTRARY TO U.S. AND  
 INTERNATIONAL LAW IS STRICTLY PROHIBITED.

REVISIONS			
LTR	DESCRIPTION	DATE	APPROVED
A	INITIAL RELEASE		

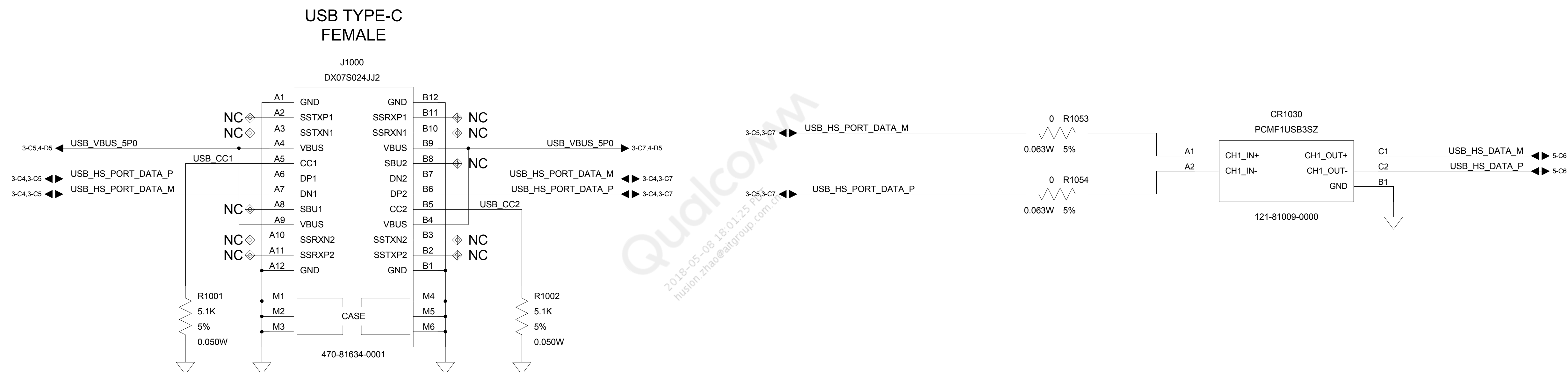



CONFIDENTIAL AND PROPRIETARY - QUALCOMM TECHNOLOGIES, INC.  
 NOT TO BE USED, COPIED, REPRODUCED, OR MODIFIED IN WHOLE OR IN PART, NOR  
 ITS CONTENTS REVEALED IN ANY MANNER TO OTHERS WITHOUT THE EXPRESS WRITTEN  
 PERMISSION OF QUALCOMM TECHNOLOGIES, INC.

THIS TECHNICAL DATA MAY BE SUBJECT TO U.S. AND INTERNATIONAL EXPORT,  
 RE-EXPORT, OR TRANSFER ("EXPORT") LAWS. DIVERSION CONTRARY TO U.S. AND  
 INTERNATIONAL LAW IS STRICTLY PROHIBITED.

REVISIONS			
LTR	DESCRIPTION	DATE	APPROVED
A	INITIAL RELEASE		

### ON BOARD LDOS

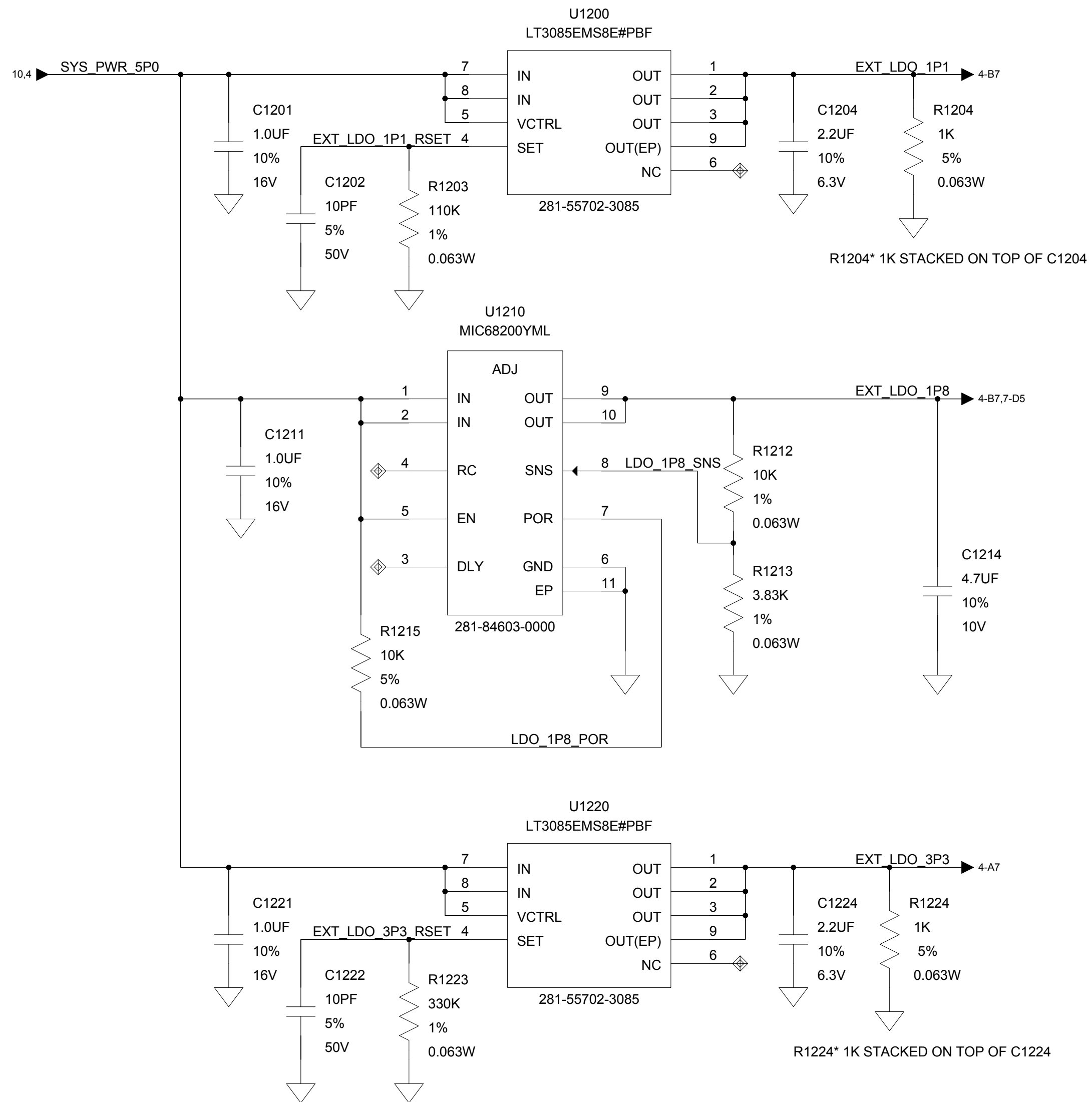

### LDO JUMPERS

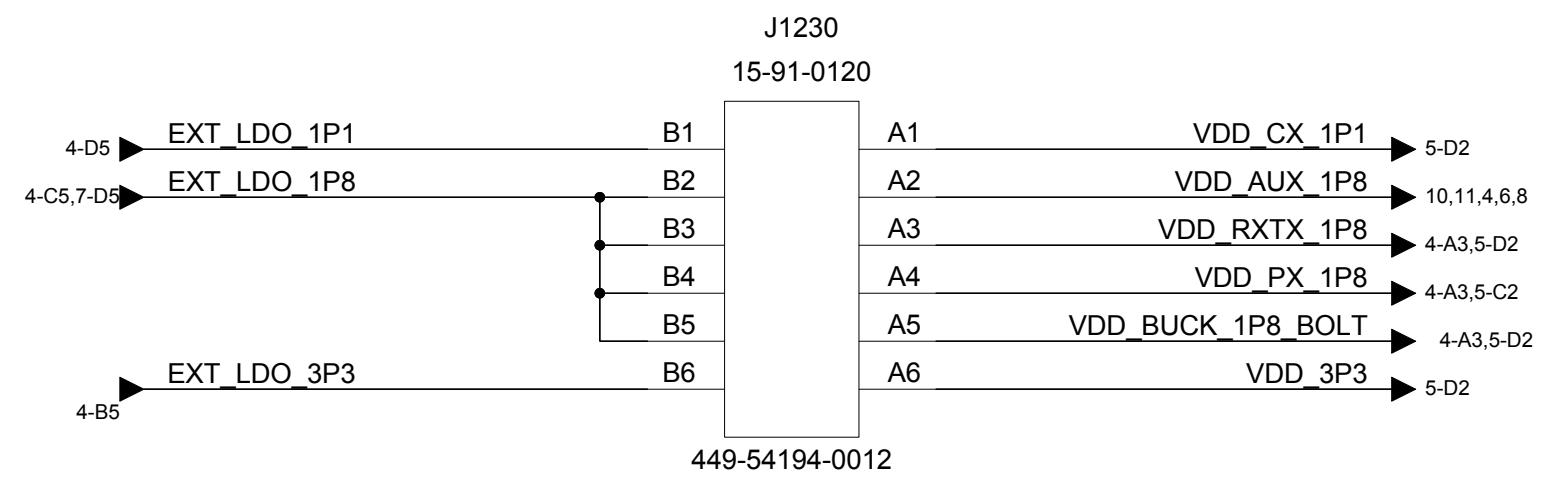

### POWER IN MUX

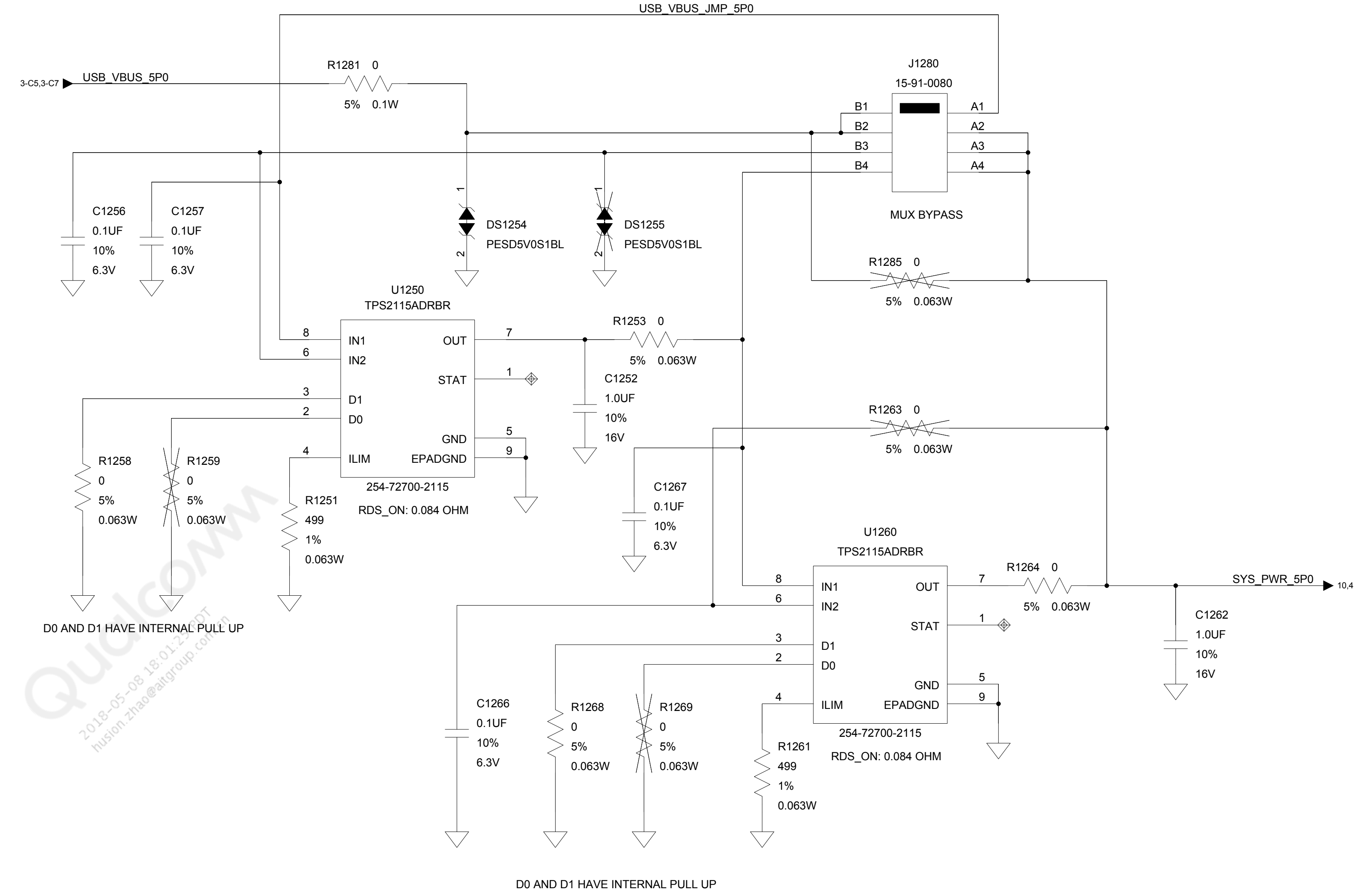

### POWER MEASUREMENT

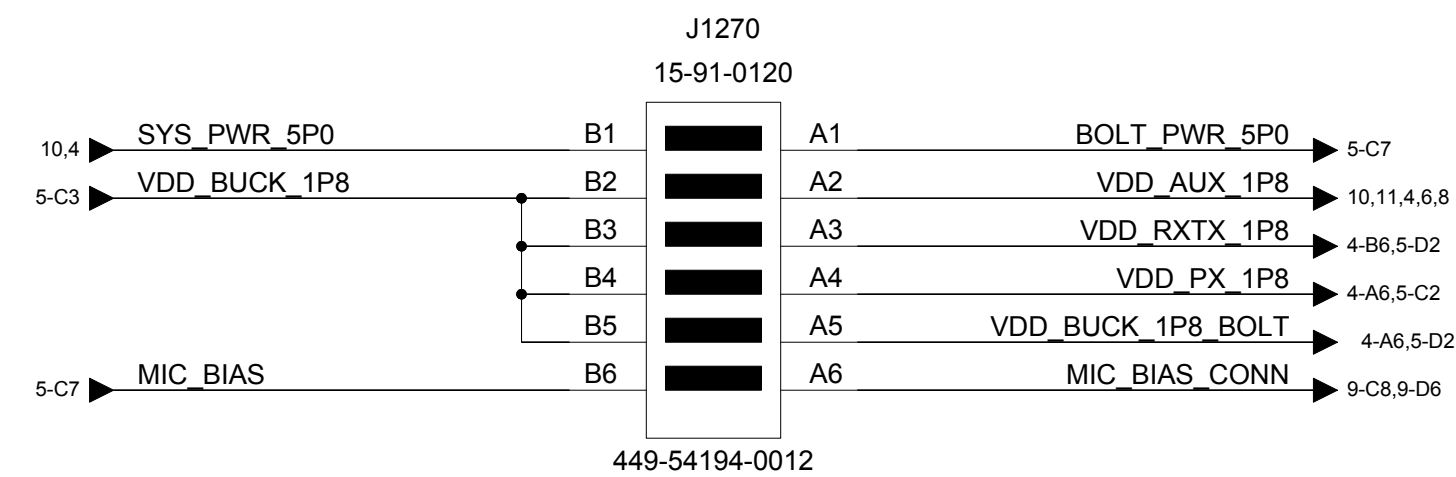

CONFIDENTIAL AND PROPRIETARY - QUALCOMM TECHNOLOGIES, INC.  
 NOT TO BE USED, COPIED, REPRODUCED, OR MODIFIED IN WHOLE OR IN PART, NOR  
 ITS CONTENTS REVEALED IN ANY MANNER TO OTHERS WITHOUT THE EXPRESS WRITTEN  
 PERMISSION OF QUALCOMM TECHNOLOGIES, INC.

THIS TECHNICAL DATA MAY BE SUBJECT TO U.S. AND INTERNATIONAL EXPORT,  
 RE-EXPORT, OR TRANSFER ("EXPORT") LAWS. DIVERSION CONTRARY TO U.S. AND  
 INTERNATIONAL LAW IS STRICTLY PROHIBITED.

Schematic is showing WHS9420 symbol.

For WHS9410 Evaluation Board, L\_MIC, R\_MIC, LED2 and LED3 pins do not have any functions.

REVISIONS			
LTR	DESCRIPTION	DATE	APPROVED
A	INITIAL RELEASE		

D

D

C

C

B

B

A

A

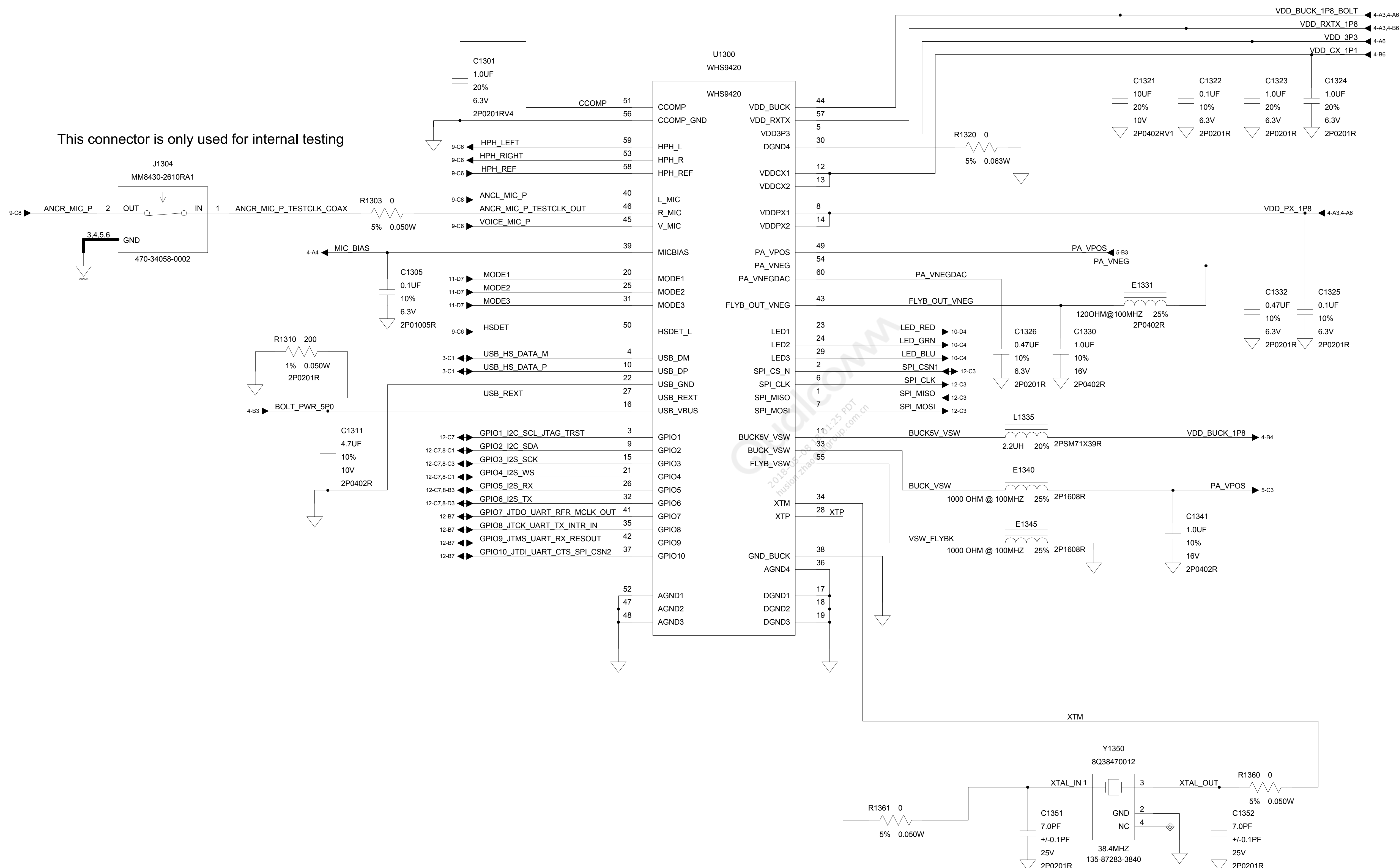

CONFIDENTIAL AND PROPRIETARY - QUALCOMM TECHNOLOGIES, INC.  
 NOT TO BE USED, COPIED, REPRODUCED, OR MODIFIED IN WHOLE OR IN PART, NOR  
 ITS CONTENTS REVEALED IN ANY MANNER TO OTHERS WITHOUT THE EXPRESS WRITTEN  
 PERMISSION OF QUALCOMM TECHNOLOGIES, INC.

THIS TECHNICAL DATA MAY BE SUBJECT TO U.S. AND INTERNATIONAL EXPORT,  
 RE-EXPORT, OR TRANSFER ("EXPORT") LAWS. DIVERSION CONTRARY TO U.S. AND  
 INTERNATIONAL LAW IS STRICTLY PROHIBITED.

REVISIONS			
LTR	DESCRIPTION	DATE	APPROVED
A	INITIAL RELEASE		

### SPI NOR FLASH

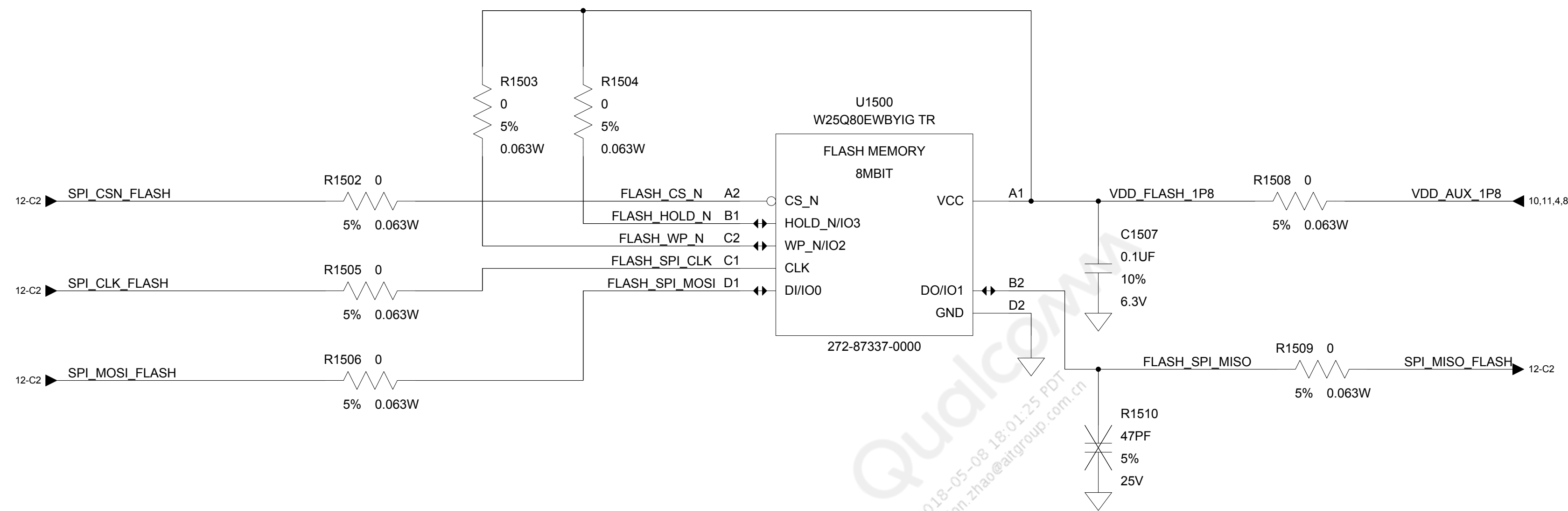

REF 1500-1599  
**SPI NOR FLASH**

SIZE D	DRAWING NO 80-PB443-42	REV A
SCALE NONE	SHEET 6	OF 12

CONFIDENTIAL AND PROPRIETARY - QUALCOMM TECHNOLOGIES, INC.  
 NOT TO BE USED, COPIED, REPRODUCED, OR MODIFIED IN WHOLE OR IN PART, NOR  
 ITS CONTENTS REVEALED IN ANY MANNER TO OTHERS WITHOUT THE EXPRESS WRITTEN  
 PERMISSION OF QUALCOMM TECHNOLOGIES, INC.

THIS TECHNICAL DATA MAY BE SUBJECT TO U.S. AND INTERNATIONAL EXPORT,  
 RE-EXPORT, OR TRANSFER ("EXPORT") LAWS. DIVERSION CONTRARY TO U.S. AND  
 INTERNATIONAL LAW IS STRICTLY PROHIBITED.

REVISIONS			
LTR	DESCRIPTION	DATE	APPROVED
A	INITIAL RELEASE		

### JTAG CONNECTOR

FOR USE WITH FLYSWATTER2 JTAG

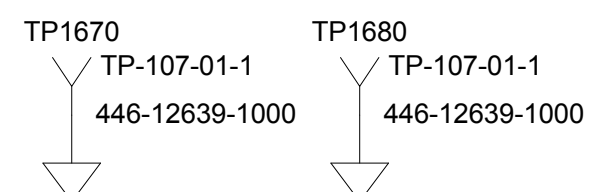
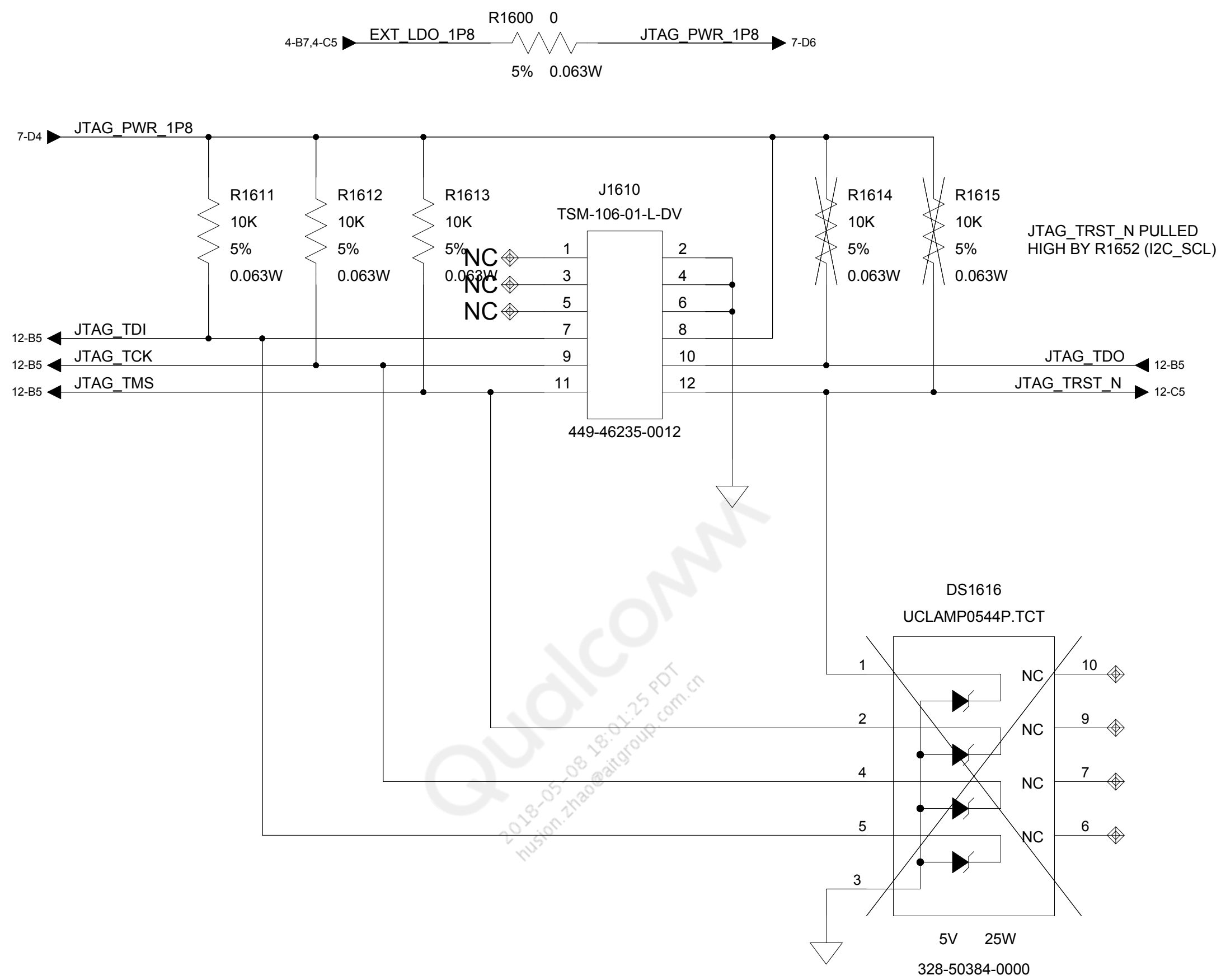

SIZE D	DRAWING NO 80-PB443-42	REV A
SCALE NONE	SHEET 7 OF 12	

CONFIDENTIAL AND PROPRIETARY - QUALCOMM TECHNOLOGIES, INC.  
 NOT TO BE USED, COPIED, REPRODUCED, OR MODIFIED IN WHOLE OR IN PART, NOR  
 ITS CONTENTS REVEALED IN ANY MANNER TO OTHERS WITHOUT THE EXPRESS WRITTEN  
 PERMISSION OF QUALCOMM TECHNOLOGIES, INC.

THIS TECHNICAL DATA MAY BE SUBJECT TO U.S. AND INTERNATIONAL EXPORT,  
 RE-EXPORT, OR TRANSFER ("EXPORT") LAWS. DIVERSION CONTRARY TO U.S. AND  
 INTERNATIONAL LAW IS STRICTLY PROHIBITED.

REVISIONS			
LTR	DESCRIPTION	DATE	APPROVED
A	INITIAL RELEASE		



Note 1: Internal test and future expansion

REF 1700-1799  
**GPIO BUTTONS**

SIZE D	DRAWING NO 80-PB443-42	REV A
SCALE NONE	SHEET 8	OF 12

CONFIDENTIAL AND PROPRIETARY - QUALCOMM TECHNOLOGIES, INC.  
 NOT TO BE USED, COPIED, REPRODUCED, OR MODIFIED IN WHOLE OR IN PART, NOR  
 ITS CONTENTS REVEALED IN ANY MANNER TO OTHERS WITHOUT THE EXPRESS WRITTEN  
 PERMISSION OF QUALCOMM TECHNOLOGIES, INC.

THIS TECHNICAL DATA MAY BE SUBJECT TO U.S. AND INTERNATIONAL EXPORT,  
 RE-EXPORT, OR TRANSFER ("EXPORT") LAWS. DIVERSION CONTRARY TO U.S. AND  
 INTERNATIONAL LAW IS STRICTLY PROHIBITED.

REVISIONS			
LTR	DESCRIPTION	DATE	APPROVED
A	INITIAL RELEASE		

D

D

C

C

B

B

A

A

SMT VOICE MIC

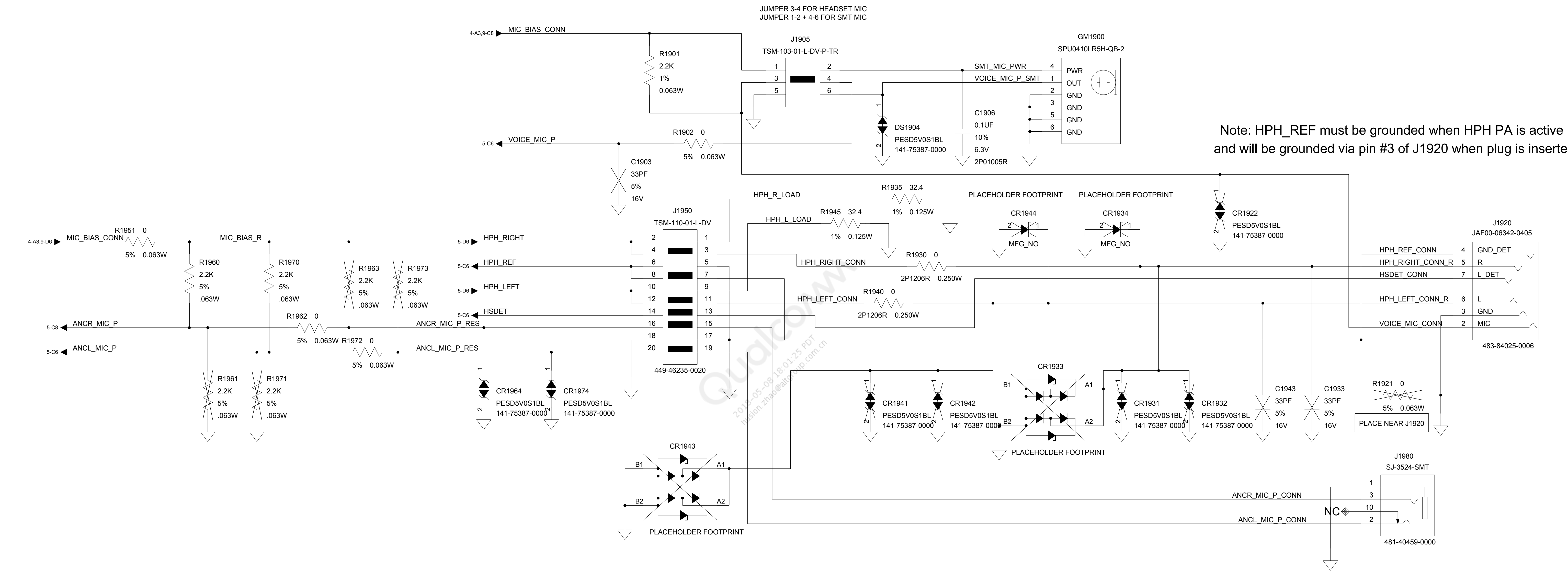

CONFIDENTIAL AND PROPRIETARY - QUALCOMM TECHNOLOGIES, INC.  
NOT TO BE USED, COPIED, REPRODUCED, OR MODIFIED IN WHOLE OR IN PART, NOR  
ITS CONTENTS REVEALED IN ANY MANNER TO OTHERS WITHOUT THE EXPRESS WRITTEN  
PERMISSION OF QUALCOMM TECHNOLOGIES, INC.

THIS TECHNICAL DATA MAY BE SUBJECT TO U.S. AND INTERNATIONAL EXPORT,  
RE-EXPORT, OR TRANSFER ("EXPORT") LAWS. DIVERSION CONTRARY TO U.S. AND  
INTERNATIONAL LAW IS STRICTLY PROHIBITED.

REVISIONS			
LTR	DESCRIPTION	DATE	APPROVED
A	INITIAL RELEASE		

D

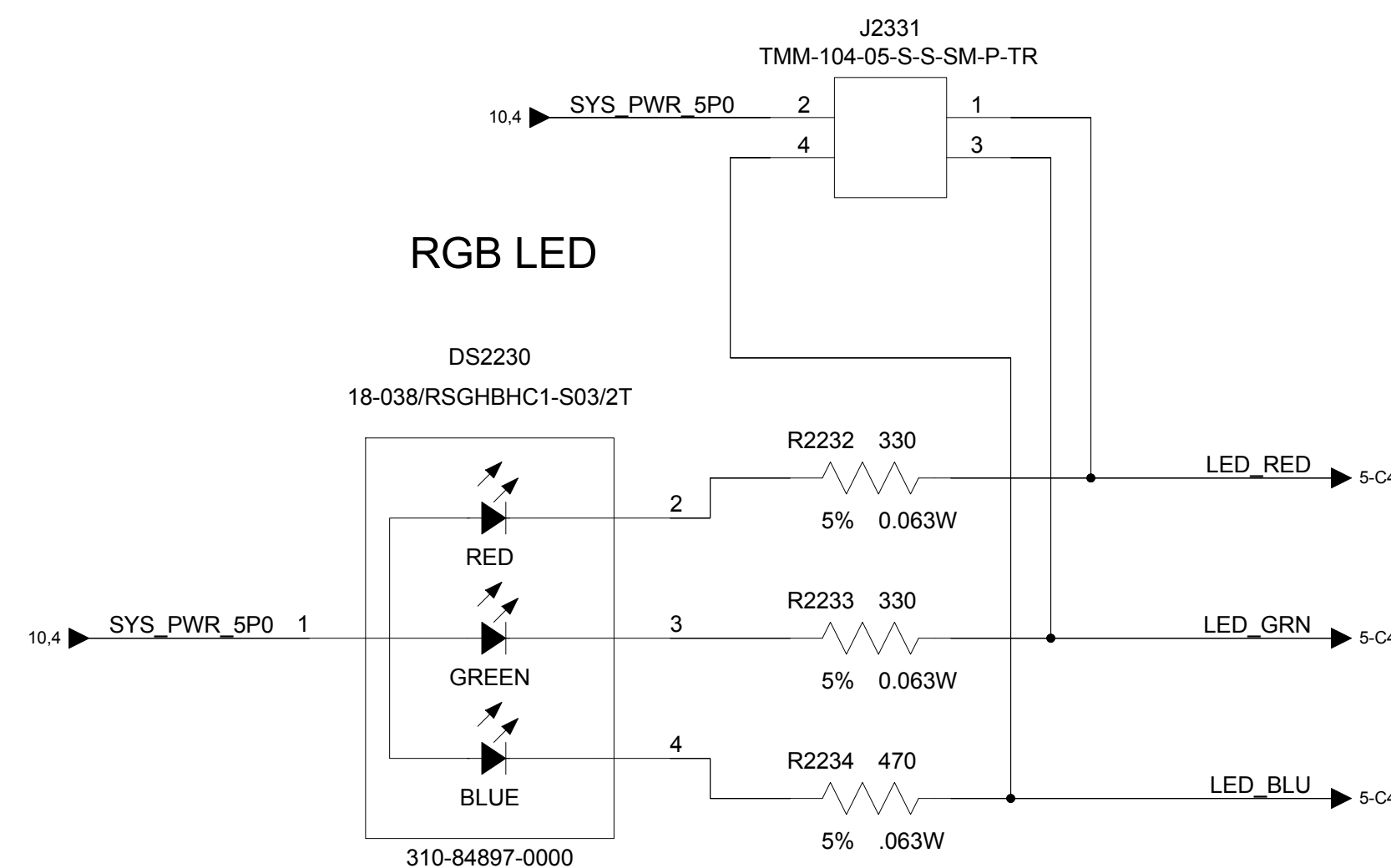

D

C

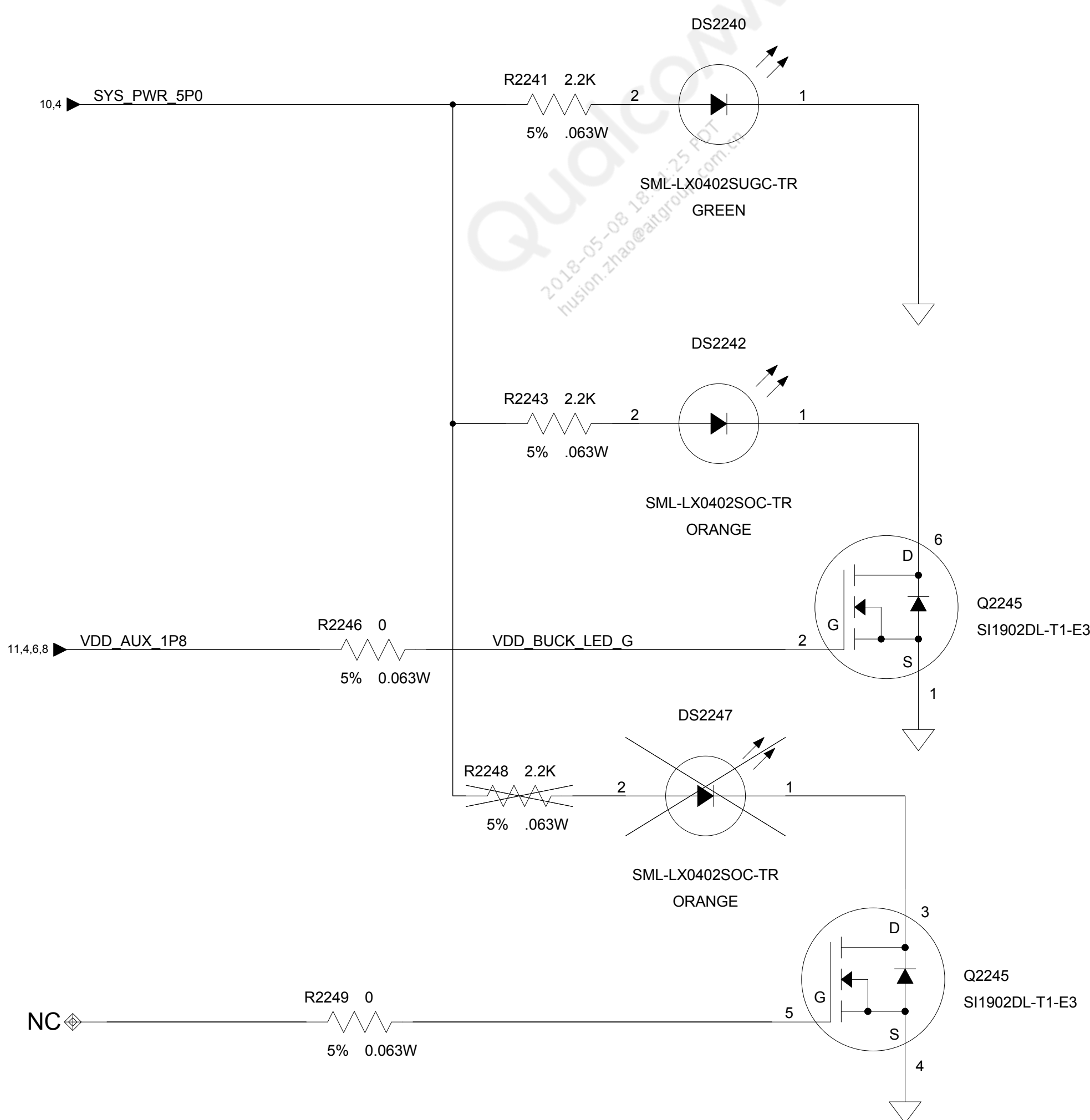

C

B

B

A

A

REF 2200-2249  
**LEDS**

SIZE D	DRAWING NO 80-PB443-42	REV A
SCALE NONE	SHEET 10	OF 12

CONFIDENTIAL AND PROPRIETARY - QUALCOMM TECHNOLOGIES, INC.  
 NOT TO BE USED, COPIED, REPRODUCED, OR MODIFIED IN WHOLE OR IN PART, NOR  
 ITS CONTENTS REVEALED IN ANY MANNER TO OTHERS WITHOUT THE EXPRESS WRITTEN  
 PERMISSION OF QUALCOMM TECHNOLOGIES, INC.

THIS TECHNICAL DATA MAY BE SUBJECT TO U.S. AND INTERNATIONAL EXPORT,  
 RE-EXPORT, OR TRANSFER ("EXPORT") LAWS. DIVERSION CONTRARY TO U.S. AND  
 INTERNATIONAL LAW IS STRICTLY PROHIBITED.

REVISIONS			
LTR	DESCRIPTION	DATE	APPROVED
A	INITIAL RELEASE		

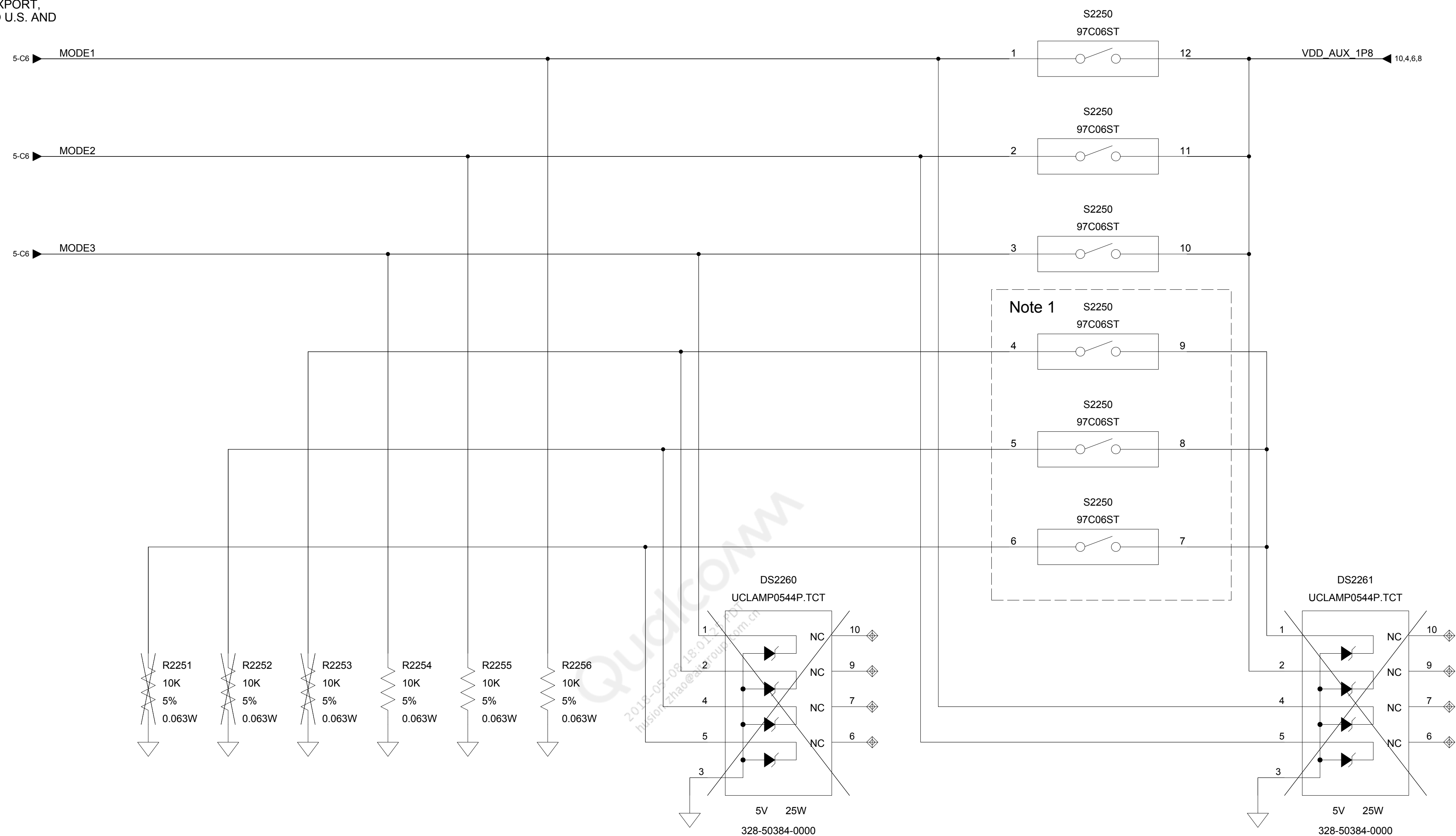

Note 1: Internal test and future expansion

REF 2250-2299

# MODE DIP SWITCHES

SIZE D	DRAWING NO 80-PB443-42	REV A
SCALE NONE	SHEET 11	OF 12



CONFIDENTIAL AND PROPRIETARY - QUALCOMM TECHNOLOGIES, INC.  
 NOT TO BE USED, COPIED, REPRODUCED, OR MODIFIED IN WHOLE OR IN PART, NOR  
 ITS CONTENTS REVEALED IN ANY MANNER TO OTHERS WITHOUT THE EXPRESS WRITTEN  
 PERMISSION OF QUALCOMM TECHNOLOGIES, INC.

THIS TECHNICAL DATA MAY BE SUBJECT TO U.S. AND INTERNATIONAL EXPORT,  
 RE-EXPORT, OR TRANSFER ("EXPORT") LAWS. DIVERSION CONTRARY TO U.S. AND  
 INTERNATIONAL LAW IS STRICTLY PROHIBITED.

REVISIONS			
LTR	DESCRIPTION	DATE	APPROVED
A	INITIAL RELEASE		

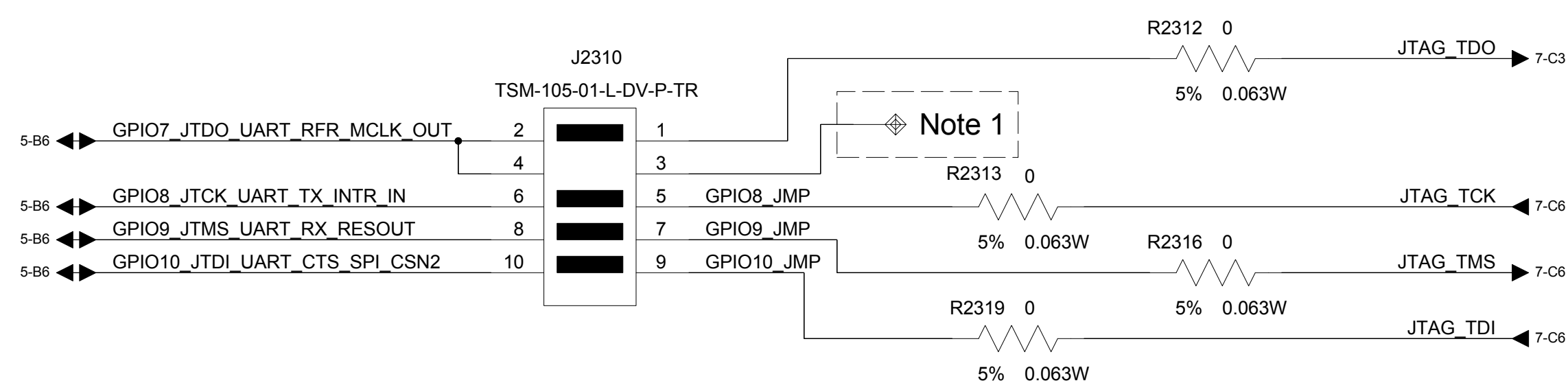
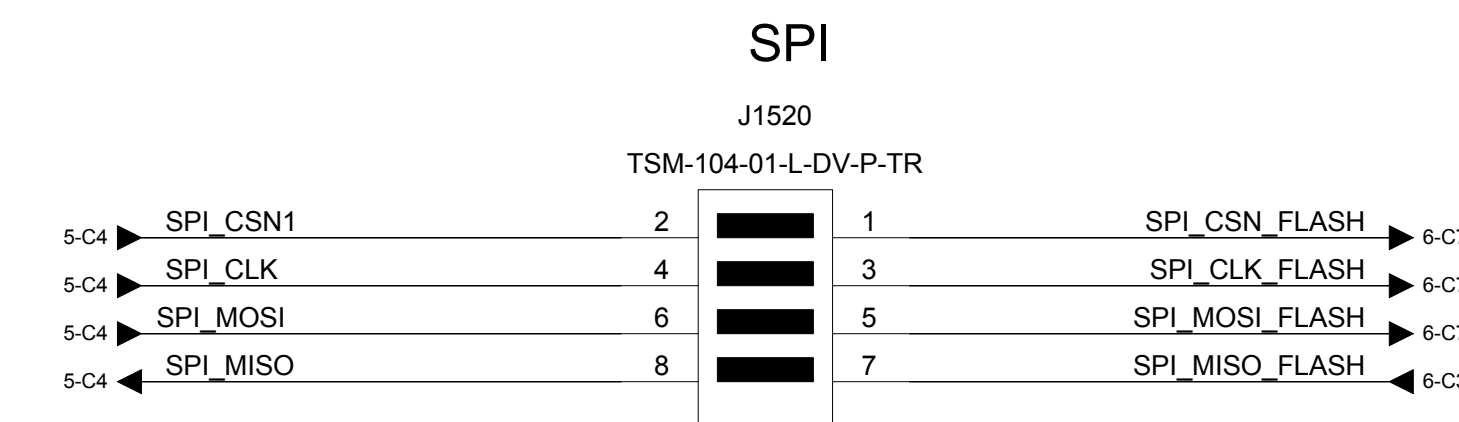
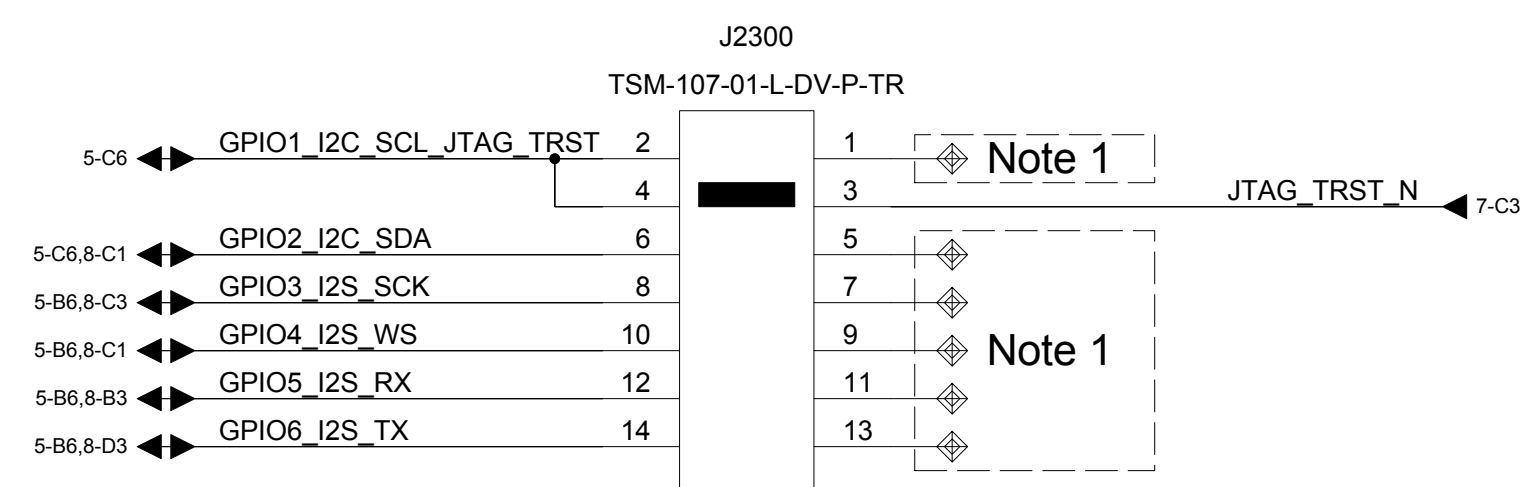

Note 1: Internal test and future expansion

REF 2300-2399  
**DIGITAL CONFIG**

SIZE D	DRAWING NO 80-PB443-42	REV A
SCALE NONE	SHEET 12	OF 12

Qualcomm  
 2018-05-08 18:01:25 PDT  
 fusion.zhao@aigroup.com.cn

## 2 Parts list

Table 2 Parts list

Item	Part description	Qty	Manufacturer	MPN	Ref des
1	RES 0 200PPM 0.25W 1206 ROHS	2	ROHM CO LTD YAGEO CORPORATION VISHAY INTERTECHNOLOGY INC KOA SPEER ELECTRONICS INC	MCR18EZHJ000 RC1206JR-07000L CRCW12060000Z0EA RK73Z2BTDD	R1930,R1940
2	RES 10K 100PPM 1% 0.063W 0402 ROHS	1	YAGEO CORPORATION VISHAY INTERTECHNOLOGY INC TA-I TECHNOLOGY CO LTD KOA SPEER ELECTRONICS INC PANASONIC INDUSTRIAL CO ROHM CO LTD	RC0402FR-0710KL CRCW040210K0FKED RM04FTN1002 RK73H1ETTP1002F ERJ2RKF1002X MCR01MZPF1002	R1212
3	RES 110K 100PPM 1% 0.063W 0402 ROHS	1	YAGEO CORPORATION WALSIN TECHNOLOGY CORP KOA SPEER ELECTRONICS INC WALSIN TECHNOLOGY CORP ROHM ELECTRONICS VISHAY INTERTECHNOLOGY INC	RC0402FR-07110KL WR04X1103FT RK73H1ETTP1103F WR04X1103FTL MCR01MZPF1103 CRCW0402110KFKED	R1203
4	RES 2.2K 100PPM 1% 0.063W 0402 ROHS	1	KOA SPEER ELECTRONICS INC VISHAY INTERTECHNOLOGY INC ROHM CO LTD PANASONIC INDUSTRIAL CO	RK73H1ETTP2201F CRCW04022K20FKED MCR01MZPF2201 ERJ2RKF2201X	R1901
5	RES 330K 100PPM 1% 0.063W 0402 ROHS	1	VISHAY INTERTECHNOLOGY INC ROHM ELECTRONICS KOA SPEER ELECTRONICS INC	CRCW0402330KFKED MCR01MZPF3303 RK73H1ETTP3303F	R1223
6	RES 3.83K 100PPM 1% 0.063W 0402 ROHS	1	ROHM ELECTRONICS KOA SPEER ELECTRONICS INC VISHAY INTERTECHNOLOGY INC	MCR01MZPF3831 RK73H1ETTP3831F CRCW04023K83FKED	R1213
7	RES 499 100PPM 1% 0.063W 0402 ROHS	2	VISHAY DALE VISHAY DALE	CRCW0402499RFKED CRCW04024990FKED	R1251,R1261
8	RES 32.4 200PPM 1% 0.125W 0805 ROHS	2	VISHAY INTERTECHNOLOGY INC PANASONIC INDUSTRIAL CO ROHM ELECTRONICS KOA SPEER ELECTRONICS INC	CRCW080532R4FKEA ERJ6ENF32R4V MCR10EZH32R4 RK73H2ATD32R4F	R1935,R1945
9	RES 0 200PPM 5% 0.050W 0201 ROHS	3	WALSIN TECHNOLOGY CORP TA-I TECHNOLOGY CO LTD CYNTEC CO. LTD. CYNTEC CO. LTD. PANASONIC INDUSTRIAL CO YAGEO CORPORATION KOA SPEER ELECTRONICS INC KOA SPEER ELECTRONICS INC VISHAY INTERTECHNOLOGY INC ROHM ELECTRONICS	WR02X000JAL RM02JTN0 PFR03S-000-XNH-39 RR0306S-000-XNH-39 ERJ1GE0R00C RC0201JR-070RL RK73Z1HTTC RK73Z1HTTB CRCW02010000Z0ED MCR006YZPJ000	R1303,R1360,R1361
10	RES 200 200PPM 5% 0.050W 0201 ROHS	1	WALSIN TECHNOLOGY CORP KOA SPEER ELECTRONICS INC KOA SPEER ELECTRONICS INC	WR02X201JAL RK73B1HTTB201J RK73B1HTTC201J	R1310
11	RES 5.1K 200PPM 5% 0.050W 0201 ROHS	2	PANASONIC INDUSTRIAL CO VENKEL CORP	ERJ1GEJ512C CR0201-20W-512JT	R1001,R1002
12	RES 0 200PPM 5% 0.063W 0402 ROHS	34	CYNTEC CO. LTD. WALSIN TECHNOLOGY CORP YAGEO CORPORATION VISHAY INTERTECHNOLOGY INC PANASONIC INDUSTRIAL CO KOA SPEER ELECTRONICS INC ROHM CO LTD	RR0510X-000-X-N WR04X000PTL RC0402JR-070RL CRCW04020000Z0ED ERJ2GE0R00X RK73Z1ETTP MCR01MZPJ000	R1053,R1054,R1253,R1258,R1259, R1263,R1264,R1268,R1269,R1285, R1320,R1502,R1503,R1504,R1505, R1506,R1508,R1509,R1600,R1700, R1701,R1702,R1703,R1902,R1921, R1951,R1962,R1972,R2246,R2249, R2312,R2313,R2316,R2319
13	RES 1K 200PPM 5% 0.063W 0402 ROHS	2	YAGEO CORPORATION NIC COMPONENTS CORP WALSIN TECHNOLOGY CORP KOA SPEER ELECTRONICS INC PANASONIC INDUSTRIAL CO ROHM CO LTD VISHAY DALE	RC0402JR-071KL NRC04J102TRF WR04X102JTL RK73B1ETTP102J ERJ2GEJ102X MCR01MZPJ102 CRCW04021K00JNED	R1204,R1224
14	RES 10K 200PPM 5% 0.063W 0402 ROHS	17	YAGEO CORPORATION CYNTEC CO. LTD. WALSIN TECHNOLOGY CORP PANASONIC INDUSTRIAL CO ROHM CO LTD VISHAY DALE KOA SPEER ELECTRONICS INC	RC0402JR-0710KL RR0510S-103-J-N WR04X103JTL ERJ2GEJ103X MCR01MZPJ103 CRCW040210K0JNED RK73B1ETTP103J	R1215,R1611,R1612,R1613,R1614, R1615,R1711,R1721,R1731,R1741, R1751,R2251,R2252,R2253,R2254, R2255,R2256

Item	Part description	Qty	Manufacturer	MPN	Ref des
15	RES 2.2K 200PPM 5% 0.063W 0402 ROHS	9	VISHAY INTERTECHNOLOGY INC YAGEO CORPORATION WALSIN TECHNOLOGY CORP ROHM CO LTD PANASONIC INDUSTRIAL CO VISHAY DALE KOA SPEER ELECTRONICS INC	CRCW04022K20JKED RC0402JR-072K2L WR04X222JTL MCR01MZPJ222 ERJ2GEJ222X CRCW04022K20JNED RK73B1ETTP222J	R1960,R1961,R1963,R1970,R1971, R1973,R2241,R2243,R2248
16	RES 330 200PPM 5% 0.063W 0402 ROHS	2	PANASONIC INDUSTRIAL CO KOA SPEER ELECTRONICS INC YAGEO CORPORATION ROHM CO LTD VISHAY DALE	ERJ2GEJ331X RK73B1ETTP331J RC0402JR-07330RL MCR01MZPJ331 CRCW0402330RJNED	R2232,R2233
17	RES 470 200PPM 5% 0.063W 0402 ROHS	1	KOA SPEER ELECTRONICS INC PANASONIC INDUSTRIAL CO ROHM CO LTD VISHAY INTERTECHNOLOGY INC	RK73B1ETTP471J ERJ2GEJ471X MCR01MZPJ471 CRCW0402470RJNED	R2234
18	RES 0 200PPM 5% 0.1W 0603 ROHS	1	NIC COMPONENTS CORP WALSIN TECHNOLOGY CORP YAGEO CORPORATION KOA SPEER ELECTRONICS INC ROHM CO LTD PANASONIC INDUSTRIAL CO	NRC06Z0 WR06X000PTL RC0603JR-070RL RK73Z1JTTD MCR03EJPJ000 ERJ3GEY0R00V	R1281
19	CAP,CHIP CERAMIC 7.0PF +/-0.1PF C0G/NP0 25V ROHS	2	MURATA ERIE NORTH AMERICA INC MURATA ERIE NORTH AMERICA INC AVX CORP	GRM0335C1E7R0BD01D GRM0335C1E7R0BA01D 02013A7R0BAT2A	C1351,C1352
20	CAP,CHIP CERAMIC 33PF 5% C0G/NP0 16V (W8P2) ROHS	3	MURATA ERIE NORTH AMERICA INC TDK CORP OF AMERICA AVX CORP TDK CORP OF AMERICA TDK CORP OF AMERICA TAIYO YUDEN CO LTD TAIYO YUDEN CO LTD MURATA ERIE NORTH AMERICA INC MURATA ERIE NORTH AMERICA INC MURATA ERIE NORTH AMERICA INC MURATA ERIE NORTH AMERICA INC	GRM0225C1C330JA02D C0402C0G1C330JT00NN 0101YA330JAT2A C0402C0G1C330J C0402C0G1C330JT EMK042CG330JC-FW EMK042CH330JC-F GRM0225C1C330JD05L GRM0225C1C330JD05B GRM0225C1C330JD05D GRM0225C1C330JD01D	C1903,C1933,C1943
21	CAP,CHIP CERAMIC 47PF 5% C0G/NP0 25V ROHS	1	TDK CORP OF AMERICA AVX CORP MURATA ERIE NORTH AMERICA INC TDK CORP OF AMERICA TDK CORP OF AMERICA TDK CORP OF AMERICA MURATA ERIE NORTH AMERICA INC	C0603C0G1E470JT00NN 02013A470JAT2A GRM0335C1E470JD01D C0603C0G1E470J030BA C0603C0G1E470J C0603C0G1E470JT GRM0335C1E470JA01D	R1510
22	CAP,CHIP CERAMIC 10PF 5% C0G/NP0 50V (MS) ROHS	2	TAIYO YUDEN CO LTD EPCOS INC KYOCERA CORPORATION AVX CORP CAL-CHIP ELECTRONICS SAMSUNG ELECTRO-MECHANICS YAGEO CORPORATION VISHAY INTERTECHNOLOGY INC KEMET ELECTRONICS CORP TAIYO YUDEN CO LTD TAIYO YUDEN CO LTD MURATA ERIE NORTH AMERICA INC MURATA ERIE NORTH AMERICA INC TAIYO YUDEN CO LTD KEMET ELECTRONICS CORP KEMET ELECTRONICS CORP	UMK105CG100JW-T B37920K5100J060 CM05CG100J50AH 04025A100JAT2A GMC04CG100J50NTLF CL05C100JB5NNNC CC0402JRNPO9BN100 VJ0402A100JXACW1BC C0402C100J5GACTU UMK105CG100JV-F RM UMK105CG100JV-F GRM1555C1H100JA01D GRM1555C1H100JZ01D RM UMK105CG100JW-F C0402C100J5GAC7867 C0402C100J5GAC	C1202,C1222
23	CAP,CHIP CERAMIC 0.1UF 10% X5R 6.3V (W8P2) ROHS	7	TAIYO YUDEN CO LTD AVX CORP SAMSUNG AMERICA INC SAMSUNG AMERICA INC MURATA ERIE NORTH AMERICA INC	JMK042 BJ104KC-FW 01016D104KAT2A CL02A104KQ2NNNB CL02A104KQ2NNNC GRM022R60J104KE15D	C1256,C1257,C1266,C1267,C1305, C1507,C1906
24	CAP,CHIP CERAMIC 0.1UF 10% X5R 6.3V ROHS	2	TDK CORP OF AMERICA SAMSUNG AMERICA INC TDK CORP OF AMERICA TDK CORP OF AMERICA DARFON ELECTRONICS CORP DARFON ELECTRONICS CORP DARFON ELECTRONICS CORP DARFON ELECTRONICS CORP YAGEO CORPORATION WALSIN TECHNOLOGY CORP AVX CORP VENKEL CORP AVX CORP TAIYO YUDEN CO LTD TAIYO YUDEN CO LTD MURATA ERIE NORTH AMERICA INC TAIYO YUDEN CO LTD	C0603X5R0J104KT00NN CL03A104KQ3NNNC C0603X5R0J104K030BC C0603X5R0J104K C0603X5R0J104KT C0201X5R104KCTS C0201X5R104KCAS C0603X5R104KCTS C0603X5R104KCAS CC0201KRX5R5BB104 0201X104K6R3CT 02016D104KAT4A C0201X5R6R3-104KNP 02016D104KAT2A CE JMK063BJ104KP-F JMK063BJ104KP-F GRM033R60J104KE19D RM JMK063BJ104KP-F	C1322,C1325

Item	Part description	Qty	Manufacturer	MPN	Ref des
25	CAP,CHIP CERAMIC 0.47UF 10% X5R 6.3V ROHS	2	TDK CORP OF AMERICA TAIYO YUDEN CO LTD TAIYO YUDEN CO LTD TDK CORP OF AMERICA AVX CORP SAMSUNG SEMI. INC MURATA ERIE NORTH AMERICA INC	C0603X5R0J474KTJ0NE JMK063BJ474KP-F JMK063BJ474KP C0603X5R0J474K030BC 02016D474KAT2A CL03A474KQ3NNNC GRM033R60J474KE90D	C1326,C1332
26	CAP,CHIP CERAMIC 2.2UF 10% X5R 6.3V ROHS	2	TAIYO YUDEN CO LTD TDK CORP OF AMERICA SAMSUNG ELECTRO-MECHANICS MURATA ERIE NORTH AMERICA INC MURATA ERIE NORTH AMERICA INC TDK CORP OF AMERICA TDK CORP OF AMERICA TDK CORP OF AMERICA TAIYO YUDEN CO LTD KEMET ELECTRONICS CORP	JMK105BJ225KV-F C1005X5R0J225KTJA0E CL05A225KQ5NNNC GRM155R60J225KE95D GRM155R60J225KE95J C1005X5R0J225K050BC C1005X5R0J225K C1005X5R0J225KT JMK105BJ225MV-F C0402C225K9PAC7867	C1204,C1224
27	CAP,CHIP CERAMIC 4.7UF 10% X5R 10V ROHS	2	TDK CORP OF AMERICA TAIYO YUDEN CO LTD TAIYO YUDEN CO LTD TDK CORP OF AMERICA SAMSUNG ELECTRO-MECHANICS	C1005X5R1A475KTJ00E LMK105BBJ475KV-F LDK105BBJ475KV-F C1005X5R1A475K050BC CL05A475KP5NFRNC	C1214,C1311
28	CAP,CHIP CERAMIC 1.0UF 10% X5R 16V ROHS	7	TDK CORP OF AMERICA TDK CORP OF AMERICA SAMSUNG ELECTRO-MECHANICS TDK CORP OF AMERICA TDK CORP OF AMERICA TAIYO YUDEN CO LTD MURATA ERIE NORTH AMERICA INC	C1005X5R1C105K C1005X5R1C105KT000E CL05A105K05NNNC C1005X5R1C105K050BC C1005X5R1C105KT EMK105BJ105KV-F GRM155R61C105KA12D	C1201,C1211,C1221,C1252,C1262,C1330,C1341
29	CAP,CHIP CERAMIC 1.0UF 20% X5R 6.3V ROHS	3	YAGEO CORPORATION VENKEL CORP TDK CORP OF AMERICA SAMSUNG ELECTRO-MECHANICS SAMSUNG ELECTRO-MECHANICS MURATA ERIE NORTH AMERICA INC MURATA ERIE NORTH AMERICA INC TDK CORP OF AMERICA TDK CORP OF AMERICA TAIYO YUDEN CO LTD MURATA ERIE NORTH AMERICA INC AVX CORP	CC0201MRX5R5BB105 C0201X5R6R3-105MNP C0603X5R0J105MT00NE CL03A105MQ3CSNH CL03A105MQ3CSNC GRM033R60J105MEA2J GRM033R60J105MEA2D C0603X5R0J105M030BC C0603X5R0J105MT JMK063ABJ105MP-F GRM033R60J105MEA2 02016D105MAT2A	C1301,C1323,C1324
30	CAP,CHIP CERAMIC 10UF 20% X5R 10V ROHS	1	TAIYO YUDEN CO LTD AVX CORP SAMSUNG ELECTRO-MECHANICS MURATA ERIE NORTH AMERICA INC	LMK105CBB106MVL 0402ZD106MAT2A CL05A106MP5NUNC GRM155R61A106ME11D	C1321
31	INDUCTOR,POWER 2.2UH 20% 1.2A DCR=0.250OHM HF-ROHS	1	CHILISIN ELECTRONICS CORP	HE1160808B-2R2M-Q8DG	L1335
32	BEAD,FERRITE CHIP 1200HM 400MA EMI SUPPRESSOR ROHS	1	TDK CORP OF AMERICA TDK CORP OF AMERICA TDK CORP OF AMERICA	MMZ1005Y121CT000 MMZ1005Y121CT MMZ1005Y121C	E1331
33	BEAD,FERRITE CHIP 1000OHM@100MHZ 0.8A ROHS	2	TDK CORP OF AMERICA TDK CORP OF AMERICA TDK CORP OF AMERICA	MPZ1608S102ATA00 MPZ1608S102A MPZ1608S102AT	E1340,E1345
34	FILTER,COMMON MODE W/ESD PROTECTION 1-CHANNEL ROHS	1	NXP SEMICONDUCTORS NXP SEMICONDUCTORS	PCMF1USB3S,087 PCMF1USB3SZ	CR1030
35	CRYSTAL,QUARTZ 38.4MHZ 30PPM CL=7PF ESR=60OHM ROHS	1	TXC CORP	8Q38470012	Y1350
36	DIODE,SCHOTTKY BARRIER 1A 40V ROHS	2	DIGI-KEY CORP ROHM ELECTRONICS	RB160SS-40T2RCT-ND RB160SS-40T2R	CR1934,CR1944
37	DIODE,ZENER TVS SINGLE BIDIRECTIONAL 5V-VRWM 5.5V-VBR 15KV ROHS	10	NXP SEMICONDUCTORS NXP SEMICONDUCTORS	PESD5V0S1BL PESD5V0S1BL,315	CR1922,CR1931,CR1932,CR1941,CR1942,CR1964,CR1974,DS1254,DS1255,DS1904
38	TRANSISTOR,MOSFET DUAL N-CHANNEL 20V 270MW ROHS	1	VISHAY SILICONIX FORMERLY TEMI	SI1902DL-T1-E3	Q2245
39	IC,AUTOSWITCHING POWER MUX 2.8-5.5V 1A ROHS	2	TEXAS INSTRUMENTS INC	TPS2115ADRBR	U1250,U1260
40	IC,MEMORY SERIAL FLASH DUAL/QUAD SPI NOR 8MBIT 1.65-1.95V HF-ROHS	1	WINBOND ELECTRONIC CORP	W25Q80EWBYIG TR	U1500
41	IC,VOLTAGE REGULATOR LDO 500MA ADJ OUTPUT ROHS	2	LINEAR TECHNOLOGY CORP LINEAR TECHNOLOGY CORP	LT3085EMS8E#PBF LT3085EMS8E#TRPBF	U1200,U1220
42	IC,VOLTAGE REGULATOR LDO ADJ OUT VIN=1.65-5.5V 2A HF-ROHS	1	MICREL SEMICONDUCTOR MICROCHIP TECHNOLOGY INC	MIC68200YML MIC68200YML-TR	U1210
43	IC,DIODE ESD PROTECTION 4-CHANNEL 0.8PF 8KV ROHS	2	NXP SEMICONDUCTORS NXP SEMICONDUCTORS	IP4369CX4YL IP4369CX4	CR1933,CR1943
44	SWITCH,DIP .050" PITCH 4-POS ROHS	5	OMRON ELECTRONICS INC GRAYHILL GRAYHILL	A6H-4101 97C04T 97C04RT	S1715,S1725,S1735,S1745,S1755

Item	Part description	Qty	Manufacturer	MPN	Ref des
45	SWITCH,DIP .050" PITCH 6-POS TOPTAPE-SEAL ROHS	1	GRAYHILL GRAYHILL	97C06ST 97C06SRT	S2250
46	SWITCH,TACT PUSH-BUTTON 12VDC 50MA HEIGHT=2MM ROHS	5	ALPS AMERICA	SKRKAHE010	S1710,S1720,S1730,S1740,S1750
47	LED,CHIP 1.0X0.5MM ORANGE 120MCD@20MA 610NM ROHS	2	LUMEX OPTO-COMPONENTS INC	SML-LX0402SOC-TR	DS2242,DS2247
48	LED,CHIP 1.0X0.5MM GREEN 45MCD@20MA 574NM ROHS	1	LUMEX OPTO-COMPONENTS INC	SML-LX0402SUGC-TR	DS2240
49	LED,CHIP FULL COLOR RGB 5V@20MA WATER CLEAR ROHS	1	EVERLIGHT ELECTRONICS CO	18-038/RSGBHC1-S03/2T	DS2230
50	SUPPRESSOR,TVS DIODE ARRAY 5V VC=12.5@2A ROHS	3	SEMTECH CORP	UCLAMP0544P.TCT	DS1616,DS2260,DS2261
51	SUPPRESSOR,TVS DIODE ARRAY 1-LINE 2.5V VC=8@5A ESD ROHS	5	SEMTECH CORP	UCLAMP2511T.TCT	DS1712,DS1722,DS1732,DS1742,DS1752
52	MICROPHONE,SILICON ULTRAMINI 400OHMS@1KHZ -38DB BOTTOM TYPE ROHS	1	KNOWLES ELECTRONICS INC KNOWLES ELECTRONICS INC	SPU0410LR5H-QB-7 SPU0410LR5H-QB-2	GM1900
53	TEST POINT,PCB LOOP MINI-GRAB ROHS	2	COMPONENTS CORP COMPONENTS CORP COMPONENTS CORP COMPONENTS CORP COMPONENTS CORP COMPONENTS CORP	TP-107-01-1-T TP-107-02-1 TP-107-02-5-T TP-107-02-1-T TP-107-01-1 TP-107-02-5	TP1670,TP1680
54	HEADER,VERT 0.100"CTR 0.025"SQ 2X3 SMT ROHS	1	SAMTEC INC SAMTEC INC	TSM-103-01-L-DV-P-TR TSM-103-01-L-DV	J1905
55	HEADER,VERT 0.100"CTR 0.025"SQ 2X4 SMT ROHS	1	SAMTEC INC SAMTEC INC	TSM-104-01-L-DV TSM-104-01-L-DV-P-TR	J1520
56	HEADER,VERT 0.100"CTR 0.025"SQ 2X5 SMT ROHS	1	SAMTEC INC SAMTEC INC	TSM-105-01-L-DV TSM-105-01-L-DV-P-TR	J2310
57	HEADER,VERT 0.100"CTR 0.025"SQ 2X6 ROHS	1	SAMTEC INC SAMTEC INC	TSM-106-01-L-DV-M-TR TSM-106-01-L-DV	J1610
58	HEADER,VERT 0.100"CTR 0.025"SQ 2X7 SMT ROHS	1	SAMTEC INC SAMTEC INC	TSM-107-01-L-DV TSM-107-01-L-DV-P-TR	J2300
59	HEADER,VERT 0.100"CTR 0.025"SQ 2X10 SMT ROHS	1	SAMTEC INC SAMTEC INC	TSM-110-01-L-DV TSM-110-01-L-DV-P-TR	J1950
60	CONN,HEADER VERT 100" (2.54MM) CTR 2X4-POS ROHS	1	MOLEX INC MOLEX INC	0015910080 15-91-0080	J1280
61	CONN,HEADER VERT 100" (2.54MM) CTR 2X6-POS SMT 0.38U"AU ROHS	2	MOLEX INC MOLEX INC	15-91-0120 0015910120	J1230,J1270
62	CONN,HEADER STRIP 2MM SMT 1X4 AU ROHS	1	SAMTEC INC SAMTEC INC	TMM-104-05-S-S-SM TMM-104-05-S-S-SM-P-TR	J2331
63	CONN,COAX SWITCH SMT 3X3 ROHS	1	MURATA ERIE NORTH AMERICA INC MURATA ERIE NORTH AMERICA INC	MM8430-2610RB3 MM8430-2610RA1	J1304
64	CONN,IO USB 3.1 TYPE C RA 10GBPS 24P SMT TOP AU ROHS	1	JAE ELECTRONICS INC JAE ELECTRONICS INC JAE ELECTRONICS INC	DX07S024JJ2R1300 DX07S024JJ2SR1300 DX07S024JJ2	J1000
65	CONN,STEREO JACK 3.5MM R/A SMT BLACK ROHS	1	CUI INC CUI INC	SJ-3524-SMT-TR SJ-3524-SMT	J1980
66	CONN,AUDIO RCPT RA TRRS 3.5MM NO SW TIP/GRD 6P PTH HF-ROHS	1	SHENZHEN LINKCONN ELECTRONICS CO	JAF00-06342-0405	J1920
67	WHS9410 or WHS9420	1	QTI		U1300