

Features

- Bluetooth® v4.1 specification fully qualified
- Radio includes integrated balun
- 80 MHz RISC MCU and 120 MHz Kalimba DSP
- Up to 120 MIPS DSP for intensive digital signal processing algorithms
- 24-bit audio
- 16 Mb internal flash; optional support for 64 Mb of external SPI flash
- Stereo codec with 2 channels of ADC and up to 6 microphone inputs (includes bias generation and digital microphone support)
- Audio interfaces:
 - 2 x I²S/PCM
 - 1 x SPDIF (independent of I²S/PCM ports)
- Serial interfaces: UART, USB 2.0 full-speed, I²C and SPI
- Integrated dual switch-mode regulators, linear regulators and battery charger
- 3 hardware LED controllers (for RGB) and ability to drive LCD segment display directly
- Support for up to 6 capacitive touch sensor inputs
- 6.5 x 6.5 x 1 mm, 0.5 mm pitch 112-ball VFBGA
- CSR8675 BGA application boards back compatible with CSR8670 BGA
- Green (RoHS compliant and no antimony or halogenated flame retardants)

BlueCore® CSR8675 BGA

Bluetooth Smart Ready

Low-power Solution for DSP Intensive Audio Applications

Production Information

CSR8675B

Issue 5



General Description

CSR8675 BGA consumer audio platform for wired and wireless applications integrates an ultra-low-power DSP and application processor with embedded flash memory, a high-performance stereo codec, a power management subsystem, LED and LCD drivers and capacitive touch sensor inputs in a SoC IC.

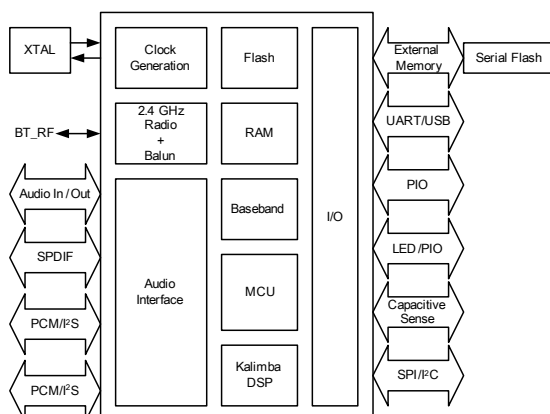

Applications

- High-end wired/wireless stereo headphones
- High-end wired/wireless stereo headsets
- High-end wired/wireless active headsets
- Wireless stereo speakers
- Low-end docking stations and soundbars
- Gaming headsets

The dual-core architecture with flash memory enables manufacturers to easily differentiate their products with new features without extending development cycles.

The enhanced Kalimba DSP coprocessor with up to 120 MIPS supports more digital signal processing requirements in stereo headphones, headsets, gaming headsets and soundbars.

The audio codec supports 2 ADC channels, up to 6 microphone inputs, stereo output and a variety of audio standards.

CSR's popular BlueCore® CSR8670™ and BlueCore®5-Multimedia platforms are software-portable to the CSR8675 BGA, with easy migration of a broad range of solutions from CSR's eXtension partners. This enables rapid time-to-market deployment for a broad range of consumer electronic products.

Ordering Information

Device	Package			Order Number
	Type	Size	Shipment Method	
CSR8675	VFBGA-112-ball (Pb free)	6.5 x 6.5 x 1 mm 0.5 mm pitch	Tape and reel	CSR8675B-IBBH-R

Note:

Minimum order quantity is 2kpcs taped and reeled.

Supply chain: CSR's manufacturing policy is to multisource volume products. For further details, contact your local sales account manager or representative.

Contacts

General information	www.csr.com
Information on this product	sales@csr.com
Customer support for this product	www.csrsupport.com
Details of compliance and standards	product.compliance@csr.com
Help with this document	comments@csr.com

CSR8675 Development Kit Ordering Information

Description	Order Number
CSR8675 BGA Audio Development Kit	DK-CSR8675-10197-1A
CSR8675 BGA Development Kit (Board Only)	DB-CSR8675-10200-1A

Device Details

Bluetooth low energy

- Dual-mode Bluetooth low energy radio
- Support for Bluetooth basic rate / EDR and low energy connections
- 3 Bluetooth low energy connections at the same time as basic rate A2DP

Bluetooth Radio

- On-chip balun (50 Ω impedance in TX and RX modes)
- No external trimming is required in production
- Bluetooth v4.1 specification software/hardware

Bluetooth Transmitter

- Typical RF transmit power
 - Basic rate 10 dBm
 - EDR -1 dB (relative power)
 - Bluetooth low energy 9 dBm
- 6-bit DAC level control
- Class 1, Class 2 and Class 3 support without the need for an external power amplifier or TX/RX switch

Bluetooth Receiver

- Typical RF receiver sensitivity:
 - Basic rate -90 dBm
 - EDR -92 dBm
 - Bluetooth low energy -93 dBm
- Integrated channel filters
- Digital demodulator for improved sensitivity and co-channel rejection
- Real-time digitised RSSI available to application
- Fast AGC for enhanced dynamic range
- Channel classification for AFH

Bluetooth Synthesiser

- Fully integrated synthesiser requires no external VCO, varactor diode, resonator or loop filter
- Compatible with crystals 19.2 MHz to 32 MHz or an external clock 19.2 MHz to 40 MHz (default 26 MHz)

Kalimba DSP

- Enhanced Kalimba 5 DSP coprocessor
- 120 MHz clock, up to 120 MIPS performance
- 24-bit fixed-point core
- Single-cycle MAC:
 - 24 x 24-bit multiply
 - 56-bit accumulate
- Improved architecture and instructions for better performance over CSR8670 BGA
- 32-bit instruction word
- Dual 24-bit data memory
- 12 K x 32-bit program RAM including 1 K instruction cache for executing out of internal flash
- 2-bank data RAM:
 - DM1 32 K x 24-bit
 - DM2 32 K x 24-bit

Baseband and Software

- 16 Mb internal flash
- Memory protection unit supporting accelerated VM
- 56 KB internal RAM, enables full-speed data transfer, mixed voice/data and full piconet support
- Logic for forward error correction, header error control, access code correlation, CRC, demodulation, encryption bit stream generation, whitening and transmit pulse shaping
- Transcoders for A-law, μ -law and linear voice via PCM and A-law, μ -law and CVSD voice over air

Audio Interfaces

- Audio codec with 2 high-quality dedicated ADCs
- 24-bit audio processing support
- 2 microphone bias generators and up to 2 analogue microphone inputs
- Up to 6 digital microphone inputs (MEMS)
- G.722 compatible, includes improved digital IIR filter path for stop-band attenuation required for G.722 compliance
- Enhanced side-tone gain control
- Supported sample rates of 8, 11.025, 16, 22.05, 32, 44.1, 48, 96 kHz and 192kHz (DAC only)

Physical Interfaces

- UART interface
- USB 2.0 interface (full-speed)
- Master and slave bit-serialiser (I²C and SPI)
- Up to 32 PIOs (includes 12 general purpose PIOs and unused digital interfaces also available as PIOs)
- SPI debug and programming interface with read access disable locking
- 2 x PCM/I²S and 1 x SPDIF supported simultaneously
- Dual/quad external serial flash memory interface
- 3 LED drivers (includes RGB) with PWM flasher on sleep clock
- Support for up to 6 capacitive touch sensor inputs
- 2 analogue PIOs

Integrated Power Control and Regulation

- 2 high-efficiency switch-mode regulators with 1.8 V and 1.35 V outputs from battery supply
- 3.3 V USB pad supply linear regulator
- Low-voltage linear regulator for internal digital supply
- Low-voltage linear regulator for internal analogue supply with 1.35 V output
- Power-on-reset detects low supply voltage
- Power management includes digital shutdown and wake-up commands with low-power crystal drive for ultra-low power Park/Sniff/Hold mode

Battery Charger

- Lithium ion / Lithium polymer battery charger with instant-on
- Fast charging support up to 200 mA with no external components
- Higher charge currents using external pass device
- Supports USB BCv1.2 CDP, DCP and SDP charger detection
- Charger pre-calibrated by CSR
- PSE compliance:
 - Design to JIS-C 8712/8714 (batteries)
 - Testing based on IEEE 1725

Auxiliary Features

- Customer application space available
- Crystal oscillator with built-in digital trimming
- Auxiliary ADC and DAC available to applications

Package Option

- 6.5 x 6.5 x 1 mm, 0.5 mm pitch 112-ball VFBGA

Functional Block Diagram

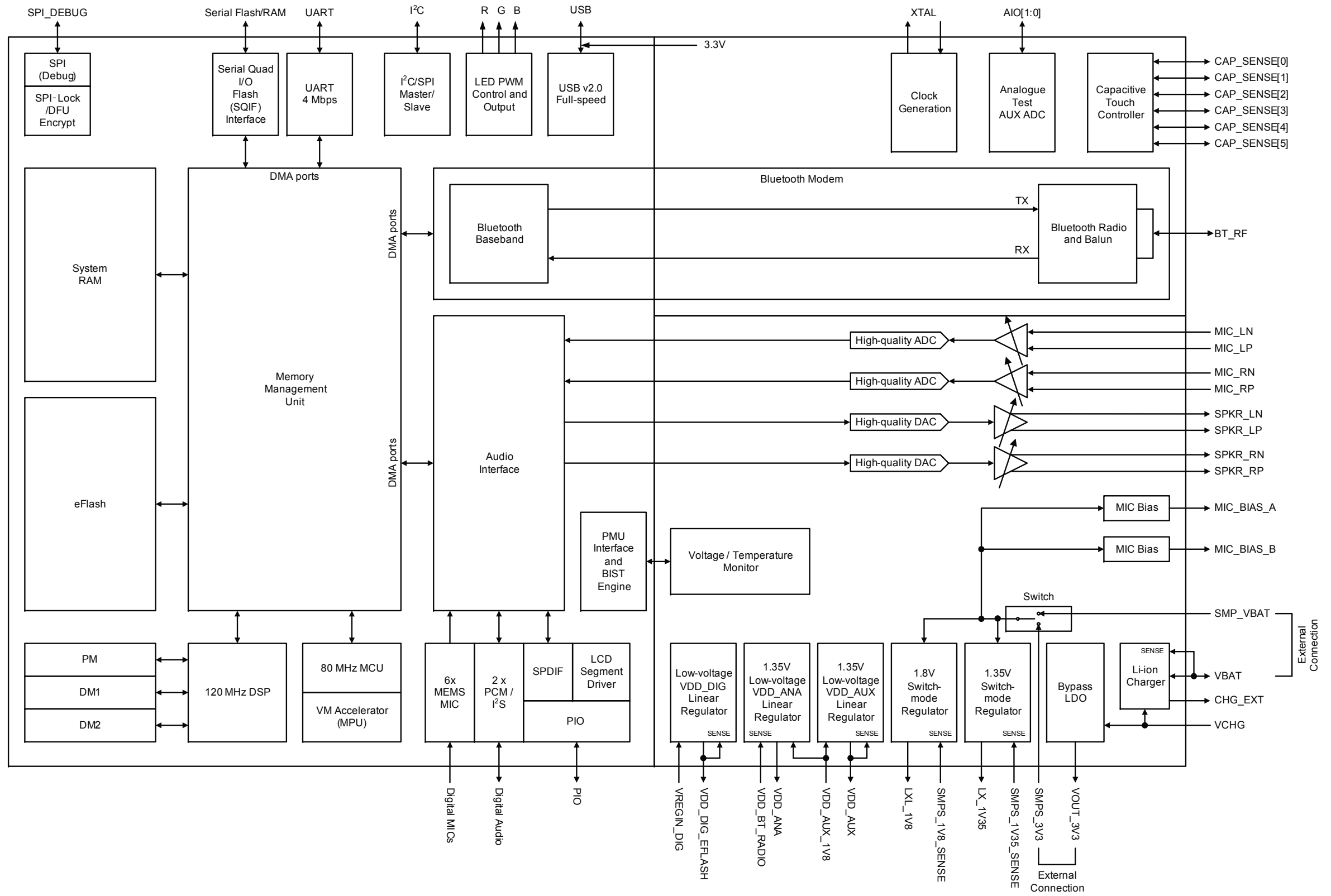

Document History

Revision	Date	Change Reason
1	27 FEB 13	Original publication of this document. Issue 1 content set as: <ul style="list-style-type: none"> ▪ Technical Overview material ▪ Functional block diagram ▪ Package information ▪ PIO configuration ▪ Example application schematic ▪ Green and RoHS information ▪ Tape and reel information
2	12 FEB 14	Full-version of Advance Information data sheet created.
3	25 SEP 14	Production Information added.
4	26 SEP 14	Additional Power Consumption information added.
5	08 OCT 14	Integrated Digital IIR Filter information updated.

Status Information

The status of this Data Sheet is **Production Information**. CSR Product Data Sheets progress according to the following format:

- **Advance Information:**
 - Information for designers concerning CSR product in development. All values specified are the target values of the design. Minimum and maximum values specified are only given as guidance to the final specification limits and must not be considered as the final values.
- **Engineering Sample:**
 - Information about initial devices. Devices are untested or partially tested prototypes, their status is described in an Engineering Sample Release Note. All values specified are the target values of the design. Minimum and maximum values specified are only given as guidance to the final specification limits and must not be considered as the final values.
 - All detailed specifications including pinouts and electrical specifications may be changed by CSR without notice.
- **Pre-production Information:**
 - Pinout and mechanical dimension specifications finalised. All values specified are the target values of the design. Minimum and maximum values specified are only given as guidance to the final specification limits and must not be considered as the final values.
 - All electrical specifications may be changed by CSR without notice.
- **Production Information:**
 - Final Data Sheet including the guaranteed minimum and maximum limits for the electrical specifications.
 - Production Data Sheets supersede all previous document versions.

Device Implementation

Important Note:

As the feature-set of the CSR8675 BGA is firmware build-specific, see the relevant software release note for the exact implementation of features on the CSR8675 BGA.

Life Support Policy and Use in Safety-critical Applications

CSR's products are not authorised for use in life-support or safety-critical applications. Use in such applications is done at the sole discretion of the customer. CSR will not warrant the use of its devices in such applications.

CSR Green Semiconductor Products and RoHS Compliance

CSR8675 BGA devices meet the requirements of Directive 2011/65/EU of the European Parliament and of the Council on the Restriction of Hazardous Substance (RoHS). CSR8675 BGA devices are free from halogenated or antimony trioxide-based flame retardants and other hazardous chemicals. For more information, see CSR's *Environmental Compliance Statement for CSR Green Semiconductor Products*.

Trademarks, Patents and Licences

Unless otherwise stated, words and logos marked with [™] or [®] are trademarks registered or owned by CSR plc or its affiliates. Bluetooth [®] and the Bluetooth [®] logos are trademarks owned by Bluetooth [®] SIG, Inc. and licensed to CSR. Other products, services and names used in this document may have been trademarked by their respective owners.

The publication of this information does not imply that any license is granted under any patent or other rights owned by CSR plc and/or its affiliates.

CSR reserves the right to make technical changes to its products as part of its development programme.

While every care has been taken to ensure the accuracy of the contents of this document, CSR cannot accept responsibility for any errors.

Refer to www.csrsupport.com for compliance and conformance to standards information.

Contents

	Ordering Information	2
	Contacts	2
	CSR8675 Development Kit Ordering Information	2
	Device Details	3
	Functional Block Diagram	4
1	Package Information	13
	1.1 Pinout Diagram	13
	1.2 Device Terminal Functions	14
	1.3 Package Dimensions	23
	1.4 PCB Design and Assembly Considerations	24
	1.5 Typical Solder Reflow Profile	24
2	System Architecture	25
3	Bluetooth Modem	26
	3.1 RF Ports	26
	3.1.1 BT_RF	26
	3.2 RF Receiver	26
	3.2.1 Low Noise Amplifier	26
	3.2.2 RSSI Analogue to Digital Converter	26
	3.3 RF Transmitter	26
	3.3.1 IQ Modulator	26
	3.3.2 Power Amplifier	27
	3.4 Bluetooth Radio Synthesiser	27
	3.5 Baseband	27
	3.5.1 Burst Mode Controller	27
	3.5.2 Physical Layer Hardware Engine	27
4	Clock Generation	28
	4.1 Clock Architecture	28
	4.2 Input Frequencies and PS Key Settings	28
	4.3 External Reference Clock	28
	4.3.1 Input: XTAL_IN	28
	4.3.2 XTAL_IN Impedance in External Mode	29
	4.3.3 Clock Timing Accuracy	29
	4.4 Crystal Oscillator: XTAL_IN and XTAL_OUT	30
	4.4.1 Crystal Calibration	30
	4.4.2 Crystal Specification	30
5	Bluetooth Stack Microcontroller	31
	5.1 VM Accelerator	31
6	Kalimba DSP	32
7	Memory Interface and Management	33
	7.1 Memory Management Unit	33
	7.2 System RAM	33
	7.3 Kalimba DSP RAM	33
	7.4 eFlash Memory (16 Mb)	33
	7.5 Serial Quad I/O Flash Interface (SQIF)	33
8	Serial Interfaces	35
	8.1 USB Interface	35
	8.2 UART Interface	35
	8.2.1 UART Configuration While Reset is Active	36
	8.3 Programming and Debug Interface	36

8.3.1	Instruction Cycle	37
8.3.2	Multi-slave Operation	37
8.3.3	SPI-lock	37
8.4	I ² C Interface	37
9	Interfaces	38
9.1	Programmable I/O Ports, PIO	38
9.2	Analogue I/O Ports, AIO	39
9.3	Capacitive Touch Sensor	39
9.3.1	Capacitive Range Control:	40
9.3.2	Sampling Front End	40
9.3.3	ADC	40
9.3.4	Digital Signal Conditioning (Digital Processing)	40
9.3.5	Software Signal Conditioning (Firmware)	41
9.3.6	VM	41
9.4	LED Drivers	41
10	Audio Interface	43
10.1	Audio Input and Output	44
10.2	Audio Codec Interface	44
10.2.1	Audio Codec Block Diagram	45
10.2.2	Codec Set-up	45
10.2.3	ADC	45
10.2.4	ADC Sample Rate Selection	46
10.2.5	ADC Audio Input Gain	46
10.2.6	ADC Pre-amplifier and ADC Analogue Gain	46
10.2.7	ADC Digital Gain	46
10.2.8	ADC Digital IIR Filter	47
10.2.9	DAC	47
10.2.10	DAC Sample Rate Selection	47
10.2.11	DAC Digital Gain	47
10.2.12	DAC Analogue Gain	48
10.2.13	DAC Digital FIR Filter	48
10.2.14	IEC 60958 Interface	48
10.2.15	Microphone Input	49
10.2.16	Digital Microphone Inputs	50
10.2.17	Line Input	51
10.2.18	Output Stage	51
10.2.19	Mono Operation	52
10.2.20	Side Tone	53
10.2.21	Integrated Digital IIR Filter	54
10.3	PCM1 and PCM2 Interface	55
10.3.1	PCM Interface Master/Slave	55
10.3.2	Long Frame Sync	56
10.3.3	Short Frame Sync	57
10.3.4	Multi-slot Operation	57
10.3.5	GCI Interface	57
10.3.6	Slots and Sample Formats	58
10.3.7	Additional Features	59
10.3.8	PCM Timing Information	59
10.3.9	PCM_CLK and PCM_SYNC Generation	63
10.3.10	PCM Configuration	63
10.4	I ² S1 and I ² S2 Interface	64
11	WLAN Coexistence Interface	67

12	Power Control and Regulation	68
12.1	1.8V Switch-mode Regulator	71
12.2	1.35V Switch-mode Regulator	72
12.3	1.8V and 1.35V Switch-mode Regulators Combined	73
12.4	Bypass LDO Linear Regulator	74
12.5	Low-voltage VDD_DIG Linear Regulator	75
12.6	Low-voltage VDD_AUX Linear Regulator	75
12.7	Low-voltage VDD_ANA Linear Regulator	75
12.8	Voltage Regulator Enable	75
12.9	External Regulators and Power Sequencing	75
12.10	Reset, RST#	76
12.10.1	Digital Pin States on Reset	76
12.10.2	Status After Reset	77
12.11	Automatic Reset Protection	77
13	Battery Charger	78
13.1	Battery Charger Hardware Operating Modes	78
13.1.1	Disabled Mode	79
13.1.2	Trickle Charge Mode	79
13.1.3	Fast Charge Mode	79
13.1.4	Standby Mode	79
13.1.5	Error Mode	79
13.2	Battery Charger Trimming and Calibration	79
13.3	VM Battery Charger Control	79
13.4	Battery Charger Firmware and PS Keys	79
13.5	External Mode	80
14	Example Application Schematic	81
15	Example Application Using Different Power Supply Configurations	82
16	Electrical Characteristics	85
16.1	Absolute Maximum Ratings	85
16.2	Recommended Operating Conditions	86
16.3	Input/Output Terminal Characteristics	87
16.3.1	Regulators: Available For External Use	87
16.3.2	Regulators: For Internal Use Only	89
16.3.3	Regulator Enable	90
16.3.4	Battery Charger	90
16.3.5	Reset	92
16.3.6	USB	93
16.3.7	Clocks	93
16.3.8	Stereo Codec: Analogue to Digital Converter	94
16.3.9	Stereo Codec: Digital to Analogue Converter	95
16.3.10	Digital	96
16.3.11	LED Driver Pads	96
16.3.12	Auxiliary ADC	97
16.3.13	Auxiliary DAC	97
16.4	ESD Protection	98
16.4.1	USB Electrostatic Discharge Immunity	98
17	Power Consumption	100
18	CSR Green Semiconductor Products and RoHS Compliance	101
19	Software	102
19.1	On-chip Software	102
19.1.1	Stand-alone CSR8675 BGA and Kalimba DSP Applications	102
19.1.2	BlueCore HCI Stack	102

19.2 Off-chip Software	103
19.2.1 CSR8675 Development Kit	103
19.2.2 eXtension Program Support	104
20 Tape and Reel Information	105
20.1 Tape Orientation	105
20.2 Tape Dimensions	105
20.3 Reel Information	106
20.4 Moisture Sensitivity Level	106
21 Document References	107
Terms and Definitions	108

List of Figures

Figure 1.1 Pinout Diagram	13
Figure 2.1 Standard Headset	25
Figure 2.2 Extended Headset	25
Figure 2.3 Processing 5.1 Channels	25
Figure 2.4 DDFA Companion Device	25
Figure 3.1 Simplified Circuit BT_RF	26
Figure 4.1 Clock Architecture	28
Figure 4.2 TCXO Clock Accuracy	29
Figure 6.1 Kalimba DSP Interface to Internal Functions	32
Figure 7.1 Serial Quad I/O Flash Interface	33
Figure 8.1 Universal Asynchronous Receiver Transmitter (UART)	35
Figure 8.2 Break Signal	36
Figure 9.1 Capacitive Touch Sensor Block Diagram	39
Figure 9.2 LED Equivalent Circuit	41
Figure 10.1 Audio Interface	43
Figure 10.2 Audio Codec Input and Output Stages	45
Figure 10.3 Audio Input Gain	46
Figure 10.4 Example Circuit for SPDIF Interface (Co-axial)	49
Figure 10.5 Example Circuit for SPDIF Interface (Optical)	49
Figure 10.6 Microphone Biasing	50
Figure 10.7 Differential Input	51
Figure 10.8 Single-ended Input	51
Figure 10.9 Speaker Output	52
Figure 10.10 Side Tone	53
Figure 10.11 PCM Interface Master	56
Figure 10.12 PCM Interface Slave	56
Figure 10.13 Long Frame Sync (Shown with 8-bit Companded Sample)	56
Figure 10.14 Short Frame Sync (Shown with 16-bit Sample)	57
Figure 10.15 Multi-slot Operation with 2 Slots and 8-bit Companded Samples	57
Figure 10.16 GCI Interface	58
Figure 10.17 16-bit Slot Length and Sample Formats	59
Figure 10.18 PCM Master Timing Long Frame Sync	60
Figure 10.19 PCM Master Timing Short Frame Sync	61
Figure 10.20 PCM Slave Timing Long Frame Sync	62
Figure 10.21 PCM Slave Timing Short Frame Sync	63
Figure 10.22 I ² S Digital Audio Interface Modes	64
Figure 10.23 Digital Audio Interface Slave Timing	65
Figure 10.24 Digital Audio Interface Master Timing	66
Figure 12.1 1.80V and 1.35V Dual-supply Switch-mode System Configuration	69

Figure 12.2	1.80V Parallel-supply Switch-mode System Configuration	70
Figure 12.3	External 1.8V System Configuration	71
Figure 12.4	1.8V Switch-mode Regulator Output Configuration	72
Figure 12.5	1.35V Switch-mode Regulator Output Configuration	73
Figure 12.6	1.8V and 1.35V Switch-mode Regulators Outputs Parallel Configuration	74
Figure 13.1	Battery Charger Mode-to-Mode Transition Diagram	78
Figure 13.2	Battery Charger External Mode Typical Configuration	80
Figure 15.1	External 1.8V Supply Example Application	82
Figure 15.2	External 3.3V Supply Example Application	83
Figure 15.3	USB Dongle Example Application	84
Figure 19.1	Stand-alone CSR8675 BGA and Kalimba DSP Applications	102
Figure 19.2	BlueCore HCI Stack	103
Figure 20.1	Tape Orientation	105
Figure 20.2	Tape Dimensions	105
Figure 20.3	Reel Dimensions	106

List of Tables

Table 1.1	RF Interface	14
Table 1.2	Clock Interface	14
Table 1.3	UART Interface	14
Table 1.4	USB Interface	14
Table 1.5	Debug SPI Interface	15
Table 1.6	PIO Port: LED Drivers	15
Table 1.7	PIO Port: Serial Quad I/O Flash/SRAM Interface	16
Table 1.8	PIO Port: PCM I ² S 1 Interface	17
Table 1.9	PIO Port: UART Interface	17
Table 1.10	PIO Port: General I/O PIO[15:8]	18
Table 1.11	PIO Port: PCM I ² S 2 Interface	18
Table 1.12	PIO Port: General I/O PIO[3:0]	19
Table 1.13	Analogue I/O Interface	19
Table 1.14	Capacitive Touch Sensor Interface	19
Table 1.15	Reset	19
Table 1.16	Analogue Audio Interface	19
Table 1.17	Power Supplies and Control	20
Table 1.18	Grounds	22
Table 4.1	PS Key Values for CDMA/3G Phone TCXO	28
Table 4.2	External Clock Specifications	29
Table 8.1	Possible UART Settings	36
Table 8.2	Instruction Cycle for a SPI Transaction	37
Table 9.1	Alternative PIO Functions	38
Table 10.1	Shared Pins on PCM/I ² S Interfaces	44
Table 10.2	ADC Audio Input Gain Rate	47
Table 10.3	DAC Digital Gain Rate Selection	48
Table 10.4	DAC Analogue Gain Rate Selection	48
Table 10.5	Side Tone Gain	53
Table 10.6	PCM Master Timing	59
Table 10.7	PCM Slave Timing	62
Table 10.8	Digital Audio Interface Slave Timing	65
Table 10.9	I ² S Slave Mode Timing	65
Table 10.10	Digital Audio Interface Master Timing	66
Table 10.11	I ² S Master Mode Timing Parameters, WS and SCK as Outputs	66

Table 12.1	Recommended Configurations for Power Control and Regulation	68
Table 12.2	Pin States on Reset	76
Table 13.1	Battery Charger Operating Modes Determined by Battery Voltage and Current	78
Table 16.1	ESD Handling Ratings	98
Table 16.2	USB Electrostatic Discharge Protection Level	98

List of Equations

Equation 4.1	Crystal Calibration Using PSKEY_ANA_FTRIM_OFFSET	30
Equation 4.2	Example of PSKEY_ANA_FTRIM_OFFSET Value for 2402.0168MHz	30
Equation 4.3	Example of PSKEY_ANA_FTRIM_OFFSET Value for 2401.9832MHz	30
Equation 9.1	LED Current	41
Equation 9.2	LED PAD Voltage	41
Equation 10.1	IIR Filter Transfer Function, $H(z)$	55
Equation 10.2	IIR Filter Plus DC Blocking Transfer Function, $H_{DC}(z)$	55
Equation 10.3	PCM_CLK Frequency Generated Using the Internal 48MHz Clock	63
Equation 10.4	PCM_SYNC Frequency Relative to PCM_CLK	63

1 Package Information

1.1 Pinout Diagram

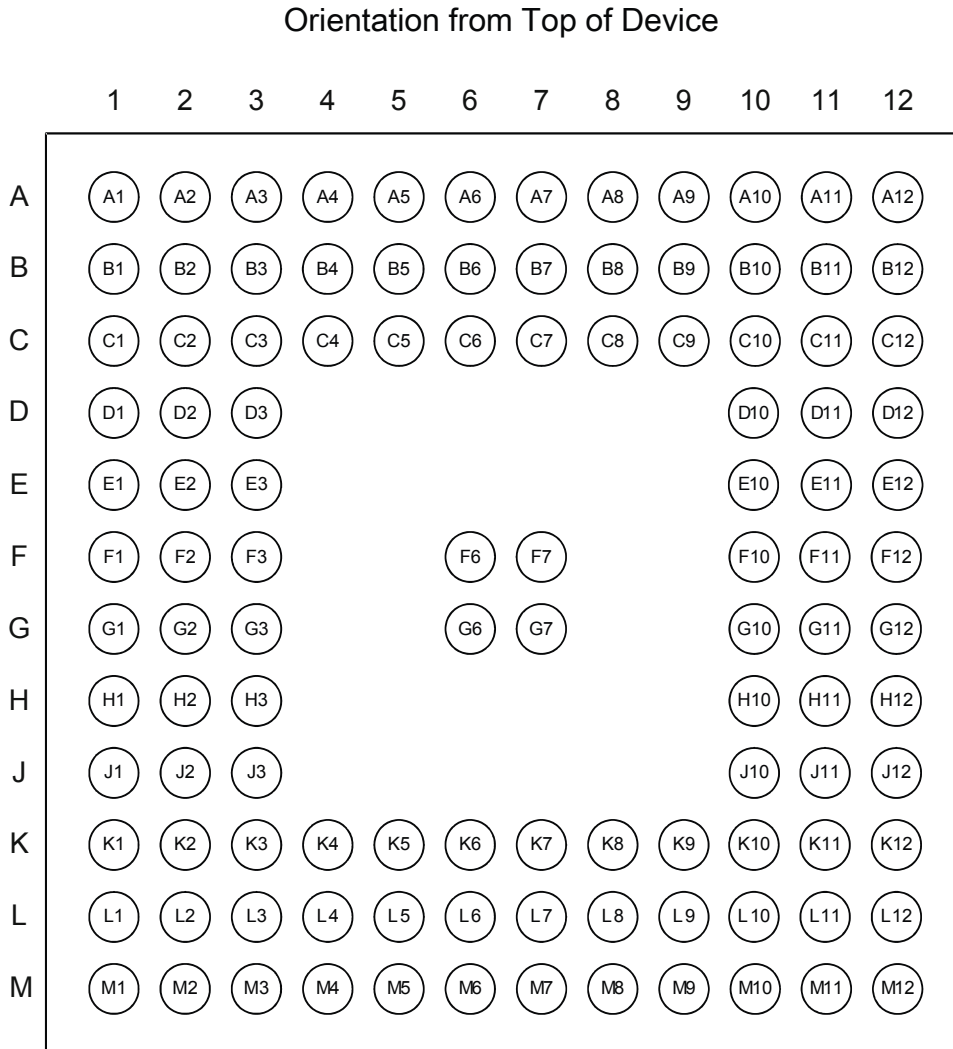

Figure 1.1: Pinout Diagram

1.2 Device Terminal Functions

Note:

Some terminals on CSR8675 BGA have programmable a pull resistor for direction (up or down) and strength (weak or strong). In this section, the pad type for these terminals represents the default configuration. For more information for the implementation of these terminals see the relevant software release note, as they are firmware build-specific.

Radio	Ball	Pad Type	Supply Domain	Description
BT_RF	A3	RF	VDD_BT_RADIO	Bluetooth 50Ω transmitter output / receiver input

Table 1.1: RF Interface

Synthesiser and Oscillator	Ball	Pad Type	Supply Domain	Description
XTAL_IN	C1	Analogue	VDD_AUX	For crystal or external clock input
XTAL_OUT	B1			Drive for crystal

Table 1.2: Clock Interface

UART	Ball	Pad Type	Supply Domain	Description
UART_TX	M3	Bidirectional with weak pull-up	VDD_PADS_1	UART data output.
UART_RX	M2	Bidirectional with strong pull-up	VDD_PADS_1	UART data input.
UART_CTS	L3	Bidirectional with weak pull-down	VDD_PADS_1	UART clear to send, active low.

Table 1.3: UART Interface

Note:

The UART ready to send pin (UART_RTS) is available on PIO[16], see Table 1.9.

USB	Ball	Pad Type	Supply Domain	Description
USB_P	M9	Bidirectional	VDD_USB	USB data plus with selectable internal 1.5kΩ pull-up resistor
USB_N	M10			USB data minus

Table 1.4: USB Interface

SPI Interface	Ball	Pad Type	Supply Domain	Description
SPI_MISO	L2	Output with weak pull-down	VDD_PADS_1	SPI data output
SPI_MOSI	G3	Input with weak pull-down		SPI data input
SPI_CS#	M1	Input with strong pull-up		Chip select for SPI, active low
SPI_CLK	E1	Input with weak pull-down		SPI clock

Table 1.5: Debug SPI Interface

Note:

Table 1.6 to Table 1.12 list alternative functions mapped on to the PIO ports. For more information, including where the SPDIF is mapped on to the PIO ports, see Section 9.1.

PIO Port: LED Drivers	Ball	Pad Type	Supply Domain	Description
PIO[31]	K5	Open drain	VDD_PADS_1 Open drain tolerant to 4.25 V	Programmable I/O line 31. Main function: <ul style="list-style-type: none"> ■ LED[1]: LED driver 1.
PIO[30]	K4	Open drain	VDD_PADS_1 Open drain tolerant to 4.25 V	Programmable I/O line 30. Main function: <ul style="list-style-type: none"> ■ LED[0]: LED driver 0.
PIO[29]	M4	Open drain	VDD_PADS_1 Open drain tolerant to 4.25 V	Programmable I/O line 29. Main function: <ul style="list-style-type: none"> ■ LED[2]: LED driver 2.

Table 1.6: PIO Port: LED Drivers

PIO Port: Serial Quad I/O Flash	Ball	Pad Type	Supply Domain	Description
PIO[28]	D12	Bidirectional with strong pull-down	VDD_PADS_3	Programmable I/O line 28. Alternative function: <ul style="list-style-type: none"> QSPI_FLASH_IO[3]: serial quad I/O flash data bit 3.
PIO[27]	C10	Bidirectional with strong pull-down	VDD_PADS_3	Programmable I/O line 27. Alternative function: <ul style="list-style-type: none"> QSPI_FLASH_IO[2]: serial quad I/O flash data bit 2.
PIO[26]	B11	Bidirectional with strong pull-down	VDD_PADS_3	Programmable I/O line 26. Alternative function: <ul style="list-style-type: none"> QSPI_FLASH_IO[1]: serial quad I/O flash data bit 1.
PIO[25]	C11	Bidirectional with strong pull-down	VDD_PADS_3	Programmable I/O line 25. Alternative function: <ul style="list-style-type: none"> QSPI_FLASH_IO[0]: serial quad I/O flash data bit 0.
PIO[24]	B10	Bidirectional with strong pull-up	VDD_PADS_3	Programmable I/O line 24. Alternative function: <ul style="list-style-type: none"> QSPI_SRAM_CS#: SPI RAM chip select.
PIO[23]	D11	Bidirectional with strong pull-up	VDD_PADS_3	Programmable I/O line 23. Alternative function: <ul style="list-style-type: none"> QSPI_FLASH_CS#: SPI flash chip select.
PIO[22]	B12	Bidirectional with strong pull-down	VDD_PADS_3	Programmable I/O line 22. Alternative function: <ul style="list-style-type: none"> QSPI_SRAM_CLK: SPI RAM clock.
PIO[21]	C12	Bidirectional with strong pull-down	VDD_PADS_3	Programmable I/O line 21. Alternative function: <ul style="list-style-type: none"> QSPI_FLASH_CLK: SPI flash clock

Table 1.7: PIO Port: Serial Quad I/O Flash/SRAM Interface

PIO Port: PCM 1/I ² S 1 Interface	Ball	Pad Type	Supply Domain	Description
PIO[20]	G2	Bidirectional with weak pull-down	VDD_PADS_1	Programmable I/O line 20. Alternative function: <ul style="list-style-type: none"> PCM1_CLK: synchronous data clock. SCK1: I²S clock
PIO[19]	H2	Bidirectional with weak pull-down	VDD_PADS_1	Programmable I/O line 19. Alternative function: <ul style="list-style-type: none"> PCM1_SYNC: synchronous data sync. WS1: I²S word select
PIO[18]	H3	Bidirectional with weak pull-down	VDD_PADS_1	Programmable I/O line 18. Alternative function: <ul style="list-style-type: none"> PCM1_OUT: synchronous data output. SD1_OUT: I²S data output
PIO[17]	F1	Bidirectional with weak pull-down	VDD_PADS_1	Programmable I/O line 17. Alternative function: <ul style="list-style-type: none"> PCM1_IN: synchronous data input. SD1_IN: I²S data input

Table 1.8: PIO Port: PCM 1/I²S 1 Interface

PIO Port: UART	Ball	Pad Type	Supply Domain	Description
PIO[16]	K3	Bidirectional with weak pull-up	VDD_PADS_1	Programmable I/O line 16. Alternative function: <ul style="list-style-type: none"> UART_RTS: UART request to send, active low.

Table 1.9: PIO Port: UART Interface

PIO Port: General I/O	Ball	Pad Type	Supply Domain	Description
PIO[15]	L6	Bidirectional with weak pull-down	VDD_PADS_2	Programmable I/O line 15.
PIO[14]	M7	Bidirectional with weak pull-down	VDD_PADS_2	Programmable I/O line 14.
PIO[13]	J10	Bidirectional with weak pull-down	VDD_PADS_2	Programmable I/O line 13.
PIO[12]	K10	Bidirectional with weak pull-down	VDD_PADS_2	Programmable I/O line 12.
PIO[11]	L9	Bidirectional with weak pull-down	VDD_PADS_2	Programmable I/O line 11.
PIO[10]	M8	Bidirectional with weak pull-down	VDD_PADS_2	Programmable I/O line 10.
PIO[9]	L10	Bidirectional with weak pull-down	VDD_PADS_2	Programmable I/O line 9.
PIO[8]	L8	Bidirectional with weak pull-down	VDD_PADS_2	Programmable I/O line 8.

Table 1.10: PIO Port: General I/O PIO[15:8]

PIO Port: PCM 2/I ² S 2 Interface	Ball	Pad Type	Supply Domain	Description
PIO[7]	K9	Bidirectional with weak pull-down	VDD_PADS_2	Programmable I/O line 7. Alternative function: <ul style="list-style-type: none"> ■ PCM2_CLK: synchronous data clock. ■ SCK2: I²S clock
PIO[6]	M6	Bidirectional with weak pull-down	VDD_PADS_2	Programmable I/O line 6. Alternative function: <ul style="list-style-type: none"> ■ PCM2_SYNC: synchronous data sync. ■ WS2: I²S word select
PIO[5]	L7	Bidirectional with weak pull-down	VDD_PADS_2	Programmable I/O line 5. Alternative function: <ul style="list-style-type: none"> ■ PCM2_OUT: synchronous data output. ■ SD2_OUT: I²S data output
PIO[4]	K8	Bidirectional with weak pull-down	VDD_PADS_2	Programmable I/O line 4. Alternative function: <ul style="list-style-type: none"> ■ PCM2_IN: synchronous data input. ■ SD2_IN: I²S data input

Table 1.11: PIO Port: PCM 2/I²S 2 Interface

PIO Port: General I/O	Ball	Pad Type	Supply Domain	Description
PIO[3]	K6	Bidirectional with weak pull-down	VDD_PADS_1	Programmable I/O line 3.
PIO[2]	M5	Bidirectional with weak pull-down	VDD_PADS_1	Programmable I/O line 2.
PIO[1]	L5	Bidirectional with weak pull-down	VDD_PADS_1	Programmable I/O line 1.
PIO[0]	L4	Bidirectional with weak pull-down	VDD_PADS_1	Programmable I/O line 0.

Table 1.12: PIO Port: General I/O PIO[3:0]

Analogue I/O	Ball	Pad Type	Supply Domain	Description
AIO[1]	D1	Bidirectional	VDD_AUX	Analogue programmable I/O line 1.
AIO[0]	C4	Bidirectional	VDD_AUX	Analogue programmable I/O line 0.

Table 1.13: Analogue I/O Interface

Capacitive Touch Sensor	Ball	Pad Type	Supply Domain	Description
CAP_SENSE[5]	F2	Analogue input	VDD_AUX_1V8	Capacitive touch sensor input.
CAP_SENSE[4]	F3			
CAP_SENSE[3]	E3			
CAP_SENSE[2]	E2			
CAP_SENSE[1]	D3			
CAP_SENSE[0]	D2			

Table 1.14: Capacitive Touch Sensor Interface

Reset	Ball	Pad Type	Supply Domain	Description
RST#	L1	Input with strong pull-up	VDD_PADS_1	Reset if low. Input debounced so must be low for >5ms to cause a reset.

Table 1.15: Reset

Codec	Ball	Pad Type	Supply Domain	Description
MIC_LP	A10	Analogue in	VDD_AUDIO	Microphone input positive, left
MIC_LN	A11			Microphone input negative, left
MIC_RP	C7	Analogue in	VDD_AUDIO	Microphone input positive, right
MIC_RN	C8			Microphone input negative, right

Codec	Ball	Pad Type	Supply Domain	Description
MIC_BIAS_A	A9	Analogue out	VBAT / VOUT_3V3	Microphone bias A
MIC_BIAS_B	B8	Analogue out	VBAT / VOUT_3V3	Microphone bias B
SPKR_LP	C5	Analogue out	VDD_AUDIO_DRV	Speaker output positive, left
SPKR_LN	C6			Speaker output negative, left
SPKR_RP	B7	Analogue out	VDD_AUDIO_DRV	Speaker output positive, right
SPKR_RN	A7			Speaker output negative, right
AU_REF	B9	Analogue in	VDD_AUDIO	Decoupling of audio reference (for high-quality audio)

Table 1.16: Analogue Audio Interface

Power Supplies and Control	Ball	Description
CHG_EXT	F11	External battery charger control.
LX_1V35	L12	1.35 V switch-mode power regulator output.
LX_1V8	J12	1.8 V switch-mode power regulator output.
SMP_VBAT	K12	1.8 V and 1.35 V switch-mode power supply regulator inputs. Must be at the same potential as VBAT.
SMPS_1V35_SENSE	M11	1.35 V switch-mode power regulator sense input.
SMPS_1V8_SENSE	F10	1.8 V switch-mode power regulator sense input.
SMPS_3V3	K11	Alternative supply via bypass regulator for 1.8 V and 1.35 V switch-mode power supply regulator inputs. Must be at the same potential as VOUT_3V3.
VBAT	H12	Battery positive terminal.
VBAT_SENSE	H11	Battery charger sense input.
VCHG	G11, G12	Battery charger input.
VOUT_3V3	F12	3.3 V bypass linear regulator output.
VDD_ANA	C2	Analogue LDO linear regulator output (1.35 V).
VDD_AUDIO	A8	Positive supply for audio (1.35 V).
VDD_AUDIO_DRV	A6	Positive supply for audio driver (1.8 V).
VDD_AUX	C3	Auxiliary LDO.
VDD_AUX_1V8	A1	Auxiliary and analogue LDO linear regulator input (1.8 V) / auxiliary circuits.

Power Supplies and Control	Ball	Description
VDD_BT_LO	A2	Bluetooth radio local oscillator supply. Connect to the 1.35 V rail via a 2.2 Ω resistor and decouple locally with a 4.7 μ F capacitor, as schematics in Section 14 and Section 15 show. These additional components are required to meet published 3Mb EDR performance with heavy DSP use. This configuration is also compatible with CSR8670 BGA in applications requiring common layout.
VDD_BT_RADIO	A5	Bluetooth radio supply, also optional sense input for 1.35 V analogue linear regulator.
VDD_DIG_EFLASH	E12, K2	Digital LDO linear regulator output (0.85 to 1.2 V). CSR recommends due to increased current draw that K2 is connected to E12 on CSR8675 BGA designs. This is back compatible with CSR8670 BGA.
VDD_EFLASH_1V8	J1	Flash supply input.
VDD_PADS_1	K1	1.7 V to 3.6 V positive supply input for input/output ports: <ul style="list-style-type: none"> ■ RST# ■ UART ■ PCM 1 ■ SPI ■ LED[2:0]/PIO[31:29] ■ PIO[3:0] Note: VDD_PADS1 must be present for CSR8675 BGA to exit reset state.
VDD_PADS_2	K7	1.7 to 3.6 V positive supply input for digital input/output ports PIO[15:4].
VDD_PADS_3	A12	1.7 to 3.6 V positive supply input for PIO[28:21] (serial quad I/O flash port).
VDD_USB	L11	Positive supply for USB ports.
VREGENABLE	E10	Regulator enable input.
VREGIN_DIG	E11	Digital LDO linear regulator input.

Table 1.17: Power Supplies and Control

Grounds	Ball	Description
VSS_AUDIO	C9	Ground connection for audio.
VSS_AUDIO_DRV	B6	Ground connection for audio driver.
VSS_BT_LO_AUX	B2	Ground connections for analogue circuitry and Bluetooth radio local oscillator.
VSS_BT_RF	A4, B5	Bluetooth radio ground.
VSS_DIG	D10, F7, G7, G10, H10	Ground connection for internal digital circuitry and pads
VSS_SMPS_1V35	M12	1.35 V switch-mode regulator ground.
VSS_SMPS_1V8	J11	1.8 V switch-mode regulator ground.

Table 1.18: Grounds

Unconnected Terminals	Ball	Description
NC or optional ground	B3, B4	Leave unconnected or ground connection.
NC	F6, G1, G6, H1, J2, J3	Leave unconnected.

1.3 Package Dimensions

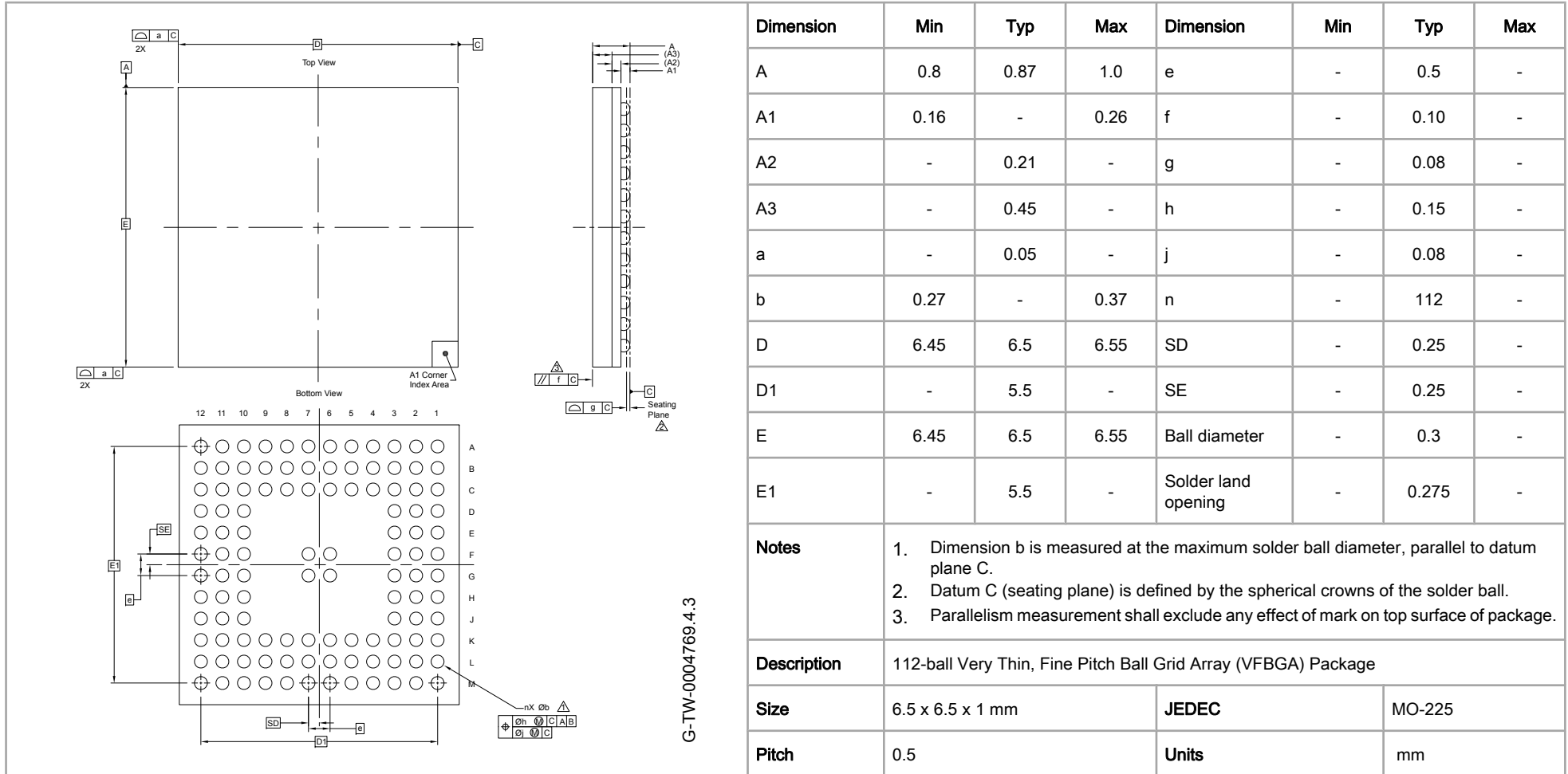

G-TW-0004769.4.3

1.4 PCB Design and Assembly Considerations

This section lists recommendations to achieve maximum board-level reliability of the 6.5 x 6.5 x 1 mm VFPGA 112-ball package:

- NSMD lands, i.e. lands smaller than the solder mask aperture, are preferred because of the greater accuracy of the metal definition process compared to the solder mask process. With solder mask defined pads, the overlap of the solder mask on the land creates a step in the solder at the land interface, which can cause stress concentration and act as a point for crack initiation.
- Ideally, use via-in-pad technology to achieve truly NSMD lands. Where this is not possible, a maximum of one trace connected to each land is preferred and this trace should be as thin as possible, this needs to take into consideration its current carrying and the RF requirements.
- 35µm thick (1oz) copper lands are recommended rather than 17µm thick (0.5oz). This results in a greater standoff which has been proven to provide greater reliability during thermal cycling.
- Land diameter should be the same as that on the package to achieve optimum reliability.
- Solder paste is preferred to flux during the assembly process because this adds to the final volume of solder in the joint, increasing its reliability.
- When using a nickel gold plating finish, the gold thickness should be kept below 0.5µm to prevent brittle gold/tin intermetallics forming in the solder.

1.5 Typical Solder Reflow Profile

See *Typical Solder Reflow Profile for Lead-free Devices* for information.

2 System Architecture

Figure 2.1 shows a completely embedded solution using internal codec.

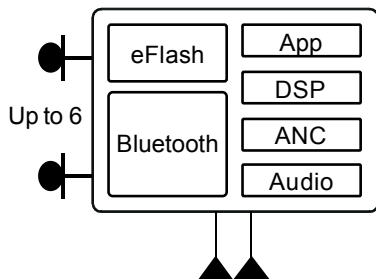

Figure 2.1: Standard Headset

Figure 2.2 shows I²S loopback to an external DSP for processing. Audio output is via the DACs of the internal codec.

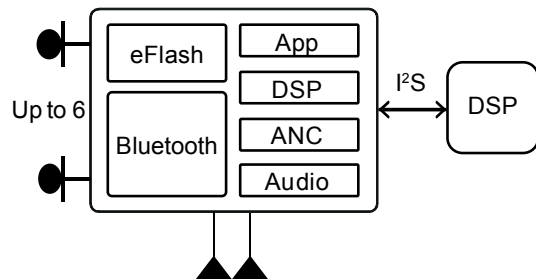

Figure 2.2: Extended Headset

Figure 2.3 shows processing 5.1 channels in the Kalimba DSP.

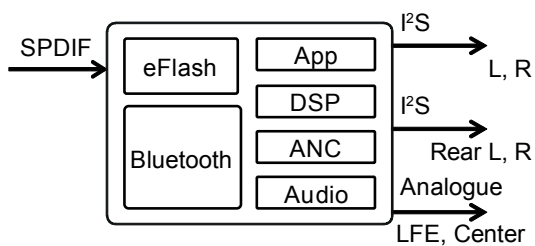

Figure 2.3: Processing 5.1 Channels

Figure 2.4 shows SPDIF input for Soundbar/AVR applications (TV/DVD input) and I²S output for DDFA or equivalent.

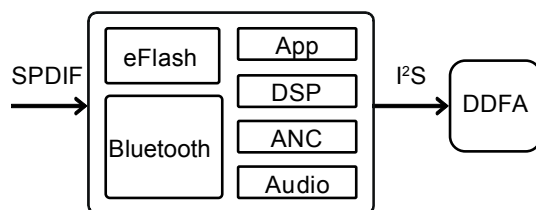

Figure 2.4: DDFA Companion Device

3 Bluetooth Modem

3.1 RF Ports

3.1.1 BT_RF

CSR8675 BGA contains an on-chip balun which combines the balanced outputs of the PA on transmit and produces the balanced input signals for the LNA required on receive. No matching components are needed as the receive mode impedance is 50Ω and the transmitter has been optimised to deliver power into a 50Ω load.

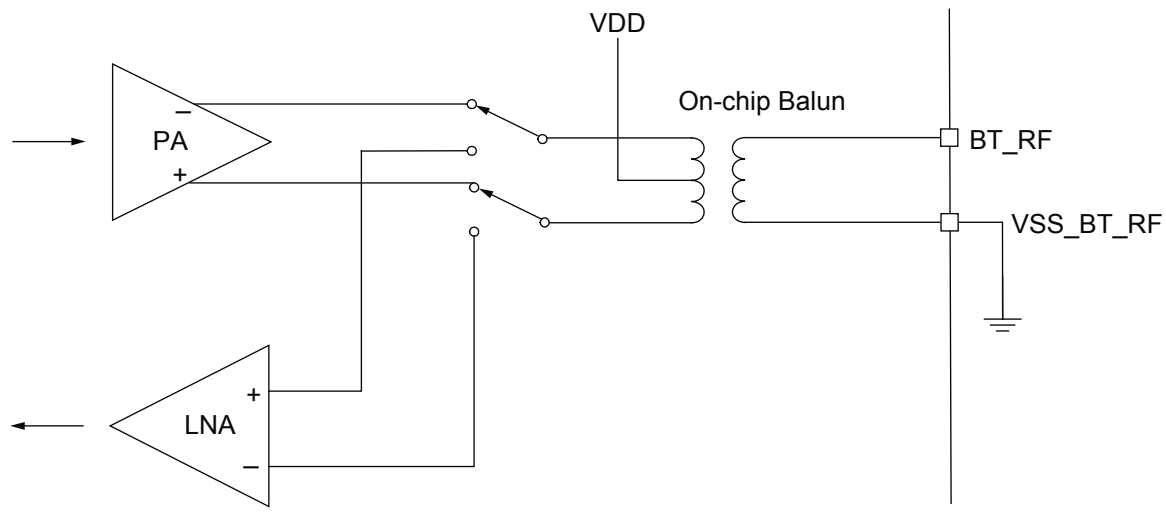

G-TW-0005523.2.2

Figure 3.1: Simplified Circuit BT_RF

3.2 RF Receiver

The receiver features a near-zero IF architecture that enables the channel filters to be integrated onto the die. Sufficient out-of-band blocking specification at the LNA input enables the receiver to operate in close proximity to GSM and W-CDMA cellular phone transmitters without being desensitised. A digital FSK discriminator means that no discriminator tank is needed and its excellent performance in the presence of noise enables CSR8675 BGA to exceed the Bluetooth requirements for co-channel and adjacent channel rejection.

For EDR, the demodulator contains an ADC which digitises the IF received signal. This information is then passed to the EDR modem.

3.2.1 Low Noise Amplifier

The LNA operates in differential mode and takes its input from the balanced port of the on-chip balun.

3.2.2 RSSI Analogue to Digital Converter

The ADC implements fast AGC. The ADC samples the RSSI voltage on a slot-by-slot basis. The front-end LNA gain is changed according to the measured RSSI value, keeping the first mixer input signal within a limited range. This improves the dynamic range of the receiver, improving performance in interference-limited environments.

3.3 RF Transmitter

3.3.1 IQ Modulator

The transmitter features a direct IQ modulator to minimise frequency drift during a transmit timeslot, which results in a controlled modulation index. Digital baseband transmit circuitry provides the required spectral shaping.

3.3.2 Power Amplifier

The internal PA output power is software controlled and configured through a PS Key. The internal PA on the CSR8675 BGA has a maximum output power that enables it to operate as a Class 1, Class 2 and Class 3 Bluetooth radio without requiring an external RF PA.

3.4 Bluetooth Radio Synthesiser

The Bluetooth radio synthesiser is fully integrated onto the die with no requirement for an external VCO screening can, varactor tuning diodes, LC resonators or loop filter. The synthesiser is guaranteed to lock in sufficient time across the guaranteed temperature range to meet the Bluetooth v4.1 specification.

3.5 Baseband

3.5.1 Burst Mode Controller

During transmission the BMC constructs a packet from header information previously loaded into memory-mapped registers by the software and payload data/voice taken from the appropriate ring buffer in the RAM. During reception, the BMC stores the packet header in memory-mapped registers and the payload data in the appropriate ring buffer in RAM. This architecture minimises the intervention required by the processor during transmission and reception.

3.5.2 Physical Layer Hardware Engine

Dedicated logic performs the following:

- Forward error correction
- Header error control
- Cyclic redundancy check
- Encryption
- Data whitening
- Access code correlation
- Audio transcoding

Firmware performs the following voice data translations and operations:

- A-law/ μ -law/linear voice data (from optional host)
- A-law/ μ -law/CVSD (over the air)
- Voice interpolation for lost packets
- Rate mismatch correction

The hardware can be used as part of a fully compliant Bluetooth v4.1 specification system.

4 Clock Generation

CSR8675 BGA requires a Bluetooth reference clock frequency of 19.2 MHz to 40 MHz (default 26 MHz) from either an externally connected crystal or from an external TCXO source.

All CSR8675 BGA internal digital clocks are generated using a phase locked loop, which is locked to the frequency of either the external 19.2 MHz to 40 MHz (default 26 MHz) reference clock source or safely free-runs at a reduced frequency.

The Bluetooth operation determines the use of the watchdog clock in low-power modes.

4.1 Clock Architecture

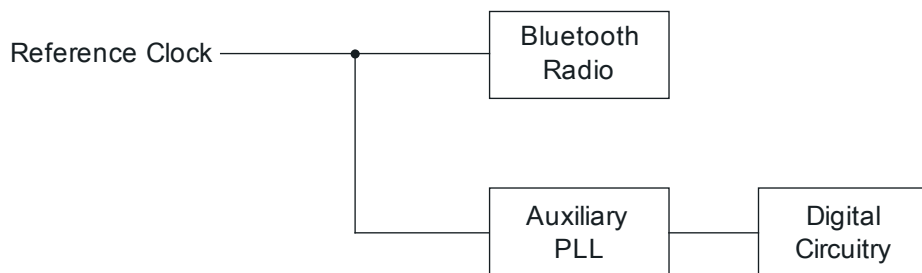

G-TW-0000189.3.3

Figure 4.1: Clock Architecture

4.2 Input Frequencies and PS Key Settings

Configure the CSR8675 BGA to operate with the chosen reference frequency. Set PSKEY_ANA_FREQ for all frequencies with an integer multiple of 250kHz. The input frequency default setting in CSR8675 BGA is 26 MHz depending on the software build. Full details are in the software release note for the specific build from www.csrsupport.com.

The following CDMA/3G phone TCXO frequencies are supported: 19.2, 19.44, 19.68, 19.8 and 38.4 MHz. The value of the PS Key is a multiple of 1kHz, so 38.4MHz is selected by using a PS Key value of 38400.

Reference Crystal Frequency (MHz)	PSKEY_ANA_FREQ (kHz)
19.20	19200
19.44	19440
19.68	19680
19.80	19800
38.40	38400
n x 0.25	n x 250
26.00 (default)	26000

Table 4.1: PS Key Values for CDMA/3G Phone TCXO

4.3 External Reference Clock

4.3.1 Input: XTAL_IN

Apply the external reference clock to the CSR8675 BGA XTAL_IN input. CSR8675 BGA is configured to accept the external reference clock at XTAL_IN by connecting XTAL_OUT to ground.

Supply the external clock with either a digital level square wave or low-level sinusoidal, coupling this directly to the XTAL_IN without the need for additional components. The DC clock level is permitted at any voltage level between the supply rails, i.e. VSS_BT_LO_AUX to VDD_AUX.

The external reference clock is required in active and deep sleep modes, so must be present when CSR8675 BGA is enabled.

Table 4.2 lists the specification for the external reference clock signal.

		Min	Typ	Max	Unit
Frequency ^(a)		19.2	26	40	MHz
Duty cycle		40:60	50:50	60:40	-
Edge jitter (at zero crossing)		-	-	10	ps rms
DC level		-0.4	-	VDD_AUX + 0.4	V
Signal level	AC coupled sinusoid	0.2	0.4	VDD_AUX ^(b)	V pk-pk
	DC coupled digital	V _{IL}	-	VSS_BT_LO_AUX	V
		V _{IH}	-	VDD_AUX ^(b)	V

Table 4.2: External Clock Specifications

^(a) The frequency should be an integer multiple of 250kHz except for the CDMA/3G frequencies

^(b) VDD_AUX is 1.35V nominal

4.3.2 XTAL_IN Impedance in External Mode

The impedance of XTAL_IN does not change significantly between operating modes. When transitioning from deep sleep to active states the capacitive load can change, see PSKEY_XTAL_OSC_CONFIG. For this reason CSR recommends using a buffered clock input.

4.3.3 Clock Timing Accuracy

Figure 4.2 shows the 250ppm timing accuracy on the external clock is required 2ms after the firmware begins to run. This guarantees that the firmware maintains timing accuracy in accordance with the Bluetooth v4.1 specification. Radio activity occurs after 6ms after the firmware starts. Therefore, at this point the timing accuracy of the external clock source must be within ±20ppm.

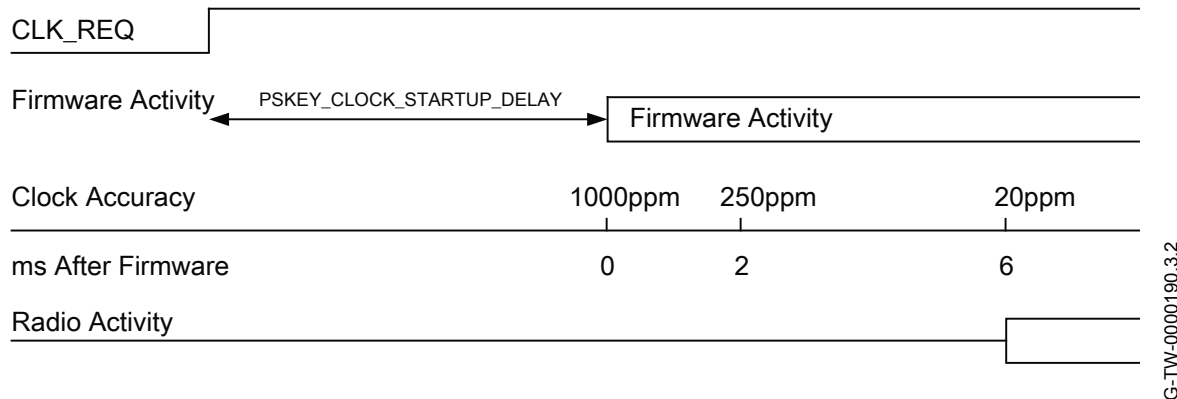

Figure 4.2: TCXO Clock Accuracy

4.4 Crystal Oscillator: XTAL_IN and XTAL_OUT

CSR8675 BGA contains a crystal driver circuit that acts as a transconductance amplifier driving an external crystal between XTAL_IN and XTAL_OUT. The crystal driver circuit forms a Pierce oscillator with the external crystal. No external crystal load capacitors are required for typical crystals.

4.4.1 Crystal Calibration

The actual crystal frequency depends on the capacitance of XTAL_IN and XTAL_OUT on the PCB and the CSR8675 BGA, as well as the capacitance of the crystal. Correct calibration of the Bluetooth radio is done on a per-device basis on the production line, with the trim value stored in non-volatile memory (PS Key).

Crystal calibration uses a single measurement. The measurement finds the actual offset from the desired frequency and the offset is stored in PSKEY_ANA_FTRIM_OFFSET. The firmware then compensates for the frequency offset on the CSR8675 BGA. Typically, a TXSTART radio test is performed to obtain the actual frequency and it is compared against the output frequency with the requested frequency using an RF analyser. The test station calculates the offset ratio and programs it into PSKEY_ANA_FTRIM_OFFSET. The value in PSKEY_ANA_FTRIM_OFFSET is a 16-bit 2's complement signed integer which specifies the fractional part of the ratio between the true crystal frequency, f_{actual} , and the value set in PSKEY_ANA_FREQ, f_{nominal} . Equation 4.1 shows the value of PSKEY_ANA_FTRIM_OFFSET in parts per 2^{20} rounded to the nearest integer.

For more information on TXSTART radio test see *BlueTest User Guide*.

$$\text{PSKEY_ANA_FTRIM_OFFSET} = \left(\frac{f_{\text{actual}}}{f_{\text{nominal}}} - 1 \right) \times 2^{20}$$

Equation 4.1: Crystal Calibration Using PSKEY_ANA_FTRIM_OFFSET

For a requested frequency of 2402MHz with an actual output of 2402.0168MHz the PSKEY_ANA_FTRIM_OFFSET value is 7, see Equation 4.2.

$$\text{PSKEY_ANA_FTRIM_OFFSET} = \left(\frac{2402.0168}{2402} - 1 \right) \times 2^{20} \approx 7$$

Equation 4.2: Example of PSKEY_ANA_FTRIM_OFFSET Value for 2402.0168MHz

For a requested frequency of 2402MHz with an actual output of 2401.9832MHz the PSKEY_ANA_FTRIM_OFFSET value is -7 (0xfff9), see Equation 4.3.

$$\text{PSKEY_ANA_FTRIM_OFFSET} = \left(\frac{2401.9832}{2402} - 1 \right) \times 2^{20} \approx -7$$

Equation 4.3: Example of PSKEY_ANA_FTRIM_OFFSET Value for 2401.9832MHz

4.4.2 Crystal Specification

Section 16.3.7 shows the specification for an external crystal.



5 Bluetooth Stack Microcontroller

The CSR8675 BGA uses a 16-bit RISC 80MHz MCU for low power consumption and efficient use of memory. It contains a single-cycle multiplier and a memory protection unit for the VM accelerator, see Section 5.1.

The MCU, interrupt controller and event timer run the Bluetooth software stack and control the Bluetooth radio and host interfaces.

5.1 VM Accelerator

CSR8675 BGA contains a VM accelerator alongside the MCU. This hardware accelerator improves the performance of VM applications.

6 Kalimba DSP

The Kalimba DSP is an open platform DSP enabling signal processing functions to be performed on over-air data or codec data to enhance audio applications. Figure 6.1 shows the Kalimba DSP interfaces to other functional blocks within CSR8675 BGA.

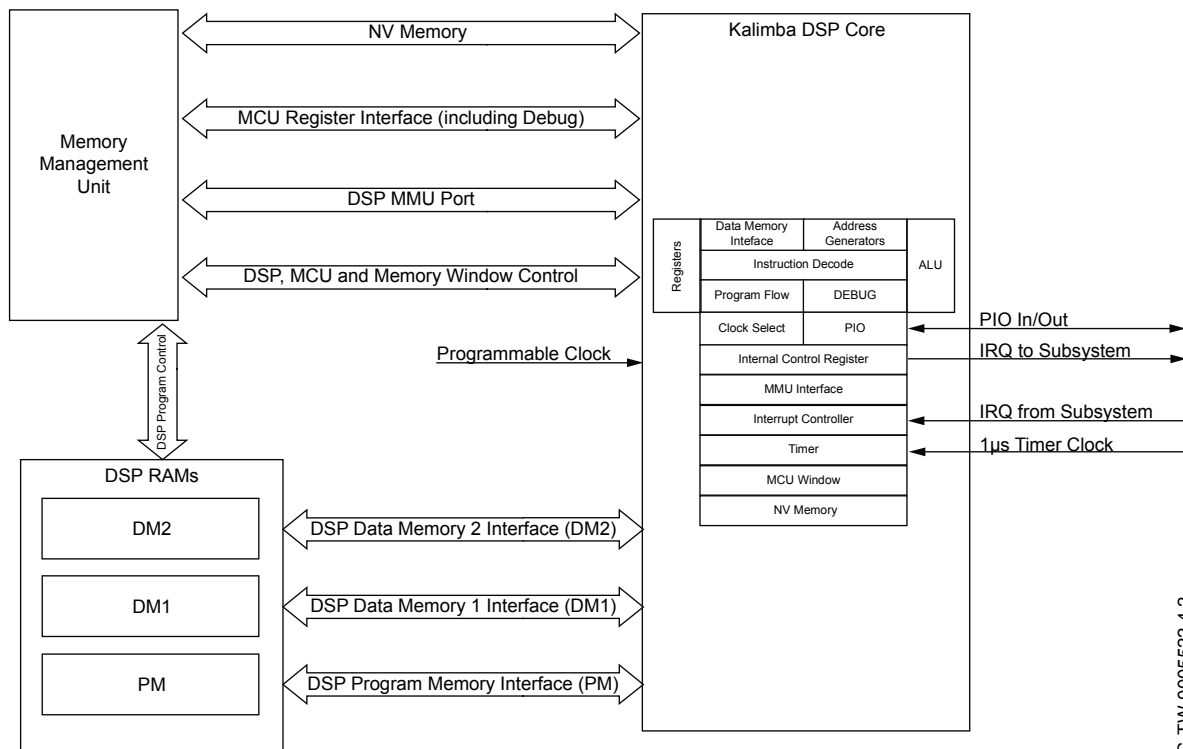

G-TW-0005522.4.2

Figure 6.1: Kalimba DSP Interface to Internal Functions

The key features of the DSP include:

- 120 MHz clock, giving up to 120 MIPS performance
- 24-bit fixed-point DSP core
- Single-cycle MAC:
 - 24 x 24-bit multiply
 - 56-bit accumulate includes 2 rMAC registers
- New instructions for improved performance over previous CSR8670 BGA architecture
- 32-bit instruction word
- Separate program memory and dual data memory, enabling an ALU operation and up to 2 memory accesses in a single cycle
- Zero overhead looping
- Zero overhead circular buffer indexing
- Single cycle barrel shifter with up to 56-bit input and 56-bit output
- Multiple cycle divide (performed in the background)
- Bit reversed addressing
- Orthogonal instruction set
- Low overhead interrupt

7 Memory Interface and Management

7.1 Memory Management Unit

The MMU provides dynamically allocated ring buffers that hold the data that is in transit between the host, the air or the Kalimba DSP. The dynamic allocation of memory ensures efficient use of the available RAM and is performed by a hardware MMU to minimise the overheads on the processor during data/voice transfers. The use of DMA ports also helps with efficient transfer of data to other peripherals.

7.2 System RAM

56 KB of integrated RAM supports the RISC MCU and is shared between the ring buffers for holding voice/data for each active connection and the general-purpose memory required by the Bluetooth stack.

7.3 Kalimba DSP RAM

Additional integrated RAM provides support for the Kalimba DSP:

- 32 K x 24-bit for data memory 1 (DM1)
- 32 K x 24-bit for data memory 2 (DM2)
- 12 K x 32-bit for program memory (PM)

Note:

The Kalimba DSP can also execute directly from internal flash or external SQIF, using a 1K-instruction on-chip cache.

7.4 eFlash Memory (16 Mb)

The internal flash memory provides 16 Mb of internal code and data storage. The internal flash stores CSR8675 BGA settings and program code, and Kalimba DSP coprocessor code and data. For improved performance, the internal flash memory has 45 ns access time and is organised as 64-bit wide.

7.5 Serial Quad I/O Flash Interface (SQIF)

CSR8675 BGA supports external serial flash and SRAM ICs. This enables additional data storage areas for device-specific data. CSR8675 BGA supports serial single, dual or quad I/O devices with a 1-bit, 2-bit or 4-bit multiplexed I/O flash-memory interface. Figure 7.1 shows a typical connection between the CSR8675 BGA and a serial flash and SRAM IC.

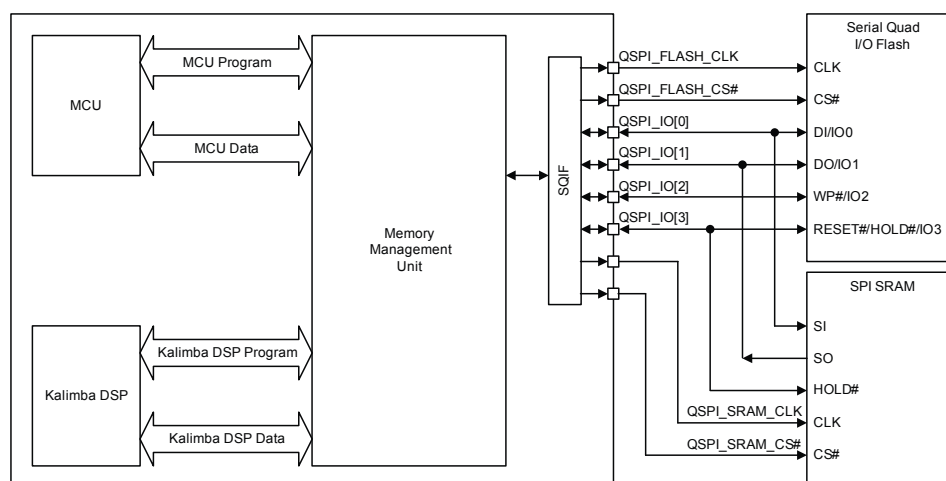

G-TW-0005514.5.2

Figure 7.1: Serial Quad I/O Flash Interface

The SQIF interface on the CSR8675 BGA supports:

- Flash and SRAM serial memory, which are also visible in the MCU and Kalimba DSP program address space

Note:

SRAM serial memory support depends on firmware version, for more information contact CSR.

- MCU and Kalimba DSP data access through a generic window
- Concurrent program and / or data accesses from the MCU and / or Kalimba DSP (although efficiency suffers)
- Separate prefetch buffers for MCU program, MCU data, Kalimba DSP program, Kalimba DSP data:
 - Each buffer is 4 x 16-bit
 - Defined minimum length prefetch
 - Prefetch continues if accesses are contiguous (and buffer not full)
 - Prefetch does not automatically restart as buffer empties
 - Prefetch is enabled and disabled by software control, which enables optimisation of sequential / random data access patterns
 - Flash and SRAM use same prefetch buffer
- Serial flash devices up to 64Mb with 1-bit, 2-bit and 4-bit wide transfers, see firmware release note for up-to-date device support
- Selected serial SRAM devices up to 512Kb with 1-bit wide transfers, see firmware release note for up-to-date device support
- Flash / SRAM performance:
 - Clocks up to 80/16MHz
 - The control and address overhead is 14/24 cycles per burst read, with support for Word Read Quad Continuous (Winbond) and High Speed Read Quad (Microchip (SST)). Microchip (SST) indexed instructions are not supported.
 - Data transfer is 4/16 cycles per 16-bits
- Flash instruction sequences:
 - Requires considerable (run-time) programmable configuration
 - Set up for either read, or write (not both)
 - Software configures SQIF for specific flash attached
- SRAM instruction sequences:
 - Interface is hard wired
 - Reads and writes can interleave without need for any reconfiguration
- All other management of serial flash / SRAM via software:
 - Memory mapped registers support transfers of data to and from the flash
 - Software needs to read the serial flash JEDEC ID in order to index a table of flash characteristics
 - Software driven sequence to enable, e.g. the Winbond Continuous Read Mode

Note:

CSR8675 BGA cannot boot up from serial flash.

8 Serial Interfaces

8.1 USB Interface

CSR8675 BGA has a full-speed (12 Mbps) USB interface for communicating with other compatible digital devices. The USB interface on CSR8675 BGA acts as a USB peripheral, responding to requests from a master host controller.

CSR8675 BGA supports the *Universal Serial Bus Specification, Revision v2.0 (USB v2.0 Specification)* and *USB Battery Charging Specification*, available from <http://www.usb.org>. For more information on how to integrate the USB interface on CSR8675 BGA see the *Bluetooth and USB Design Considerations Application Note*.

As well as describing USB basics and architecture, the application note describes:

- Power distribution for high and low bus-powered configurations
- Power distribution for self-powered configuration, which includes USB VBUS monitoring (when VBUS is >3.1)
- USB enumeration
- Electrical design guidelines for the power supply and data lines, as well as PCB tracks and the effects of ferrite beads
- USB suspend modes and Bluetooth low-power modes:
 - Global suspend
 - Selective suspend, includes remote wake
 - Wake on Bluetooth, includes permitted devices and set-up prior to selective suspend
 - Suspend mode current draw
 - PIO status in suspend mode
 - Resume, detach and wake PIOs
- Battery charging from USB, which describes dead battery provision, charge currents, charging in suspend modes and USB VBUS voltage consideration
- USB termination when interface is not in use
- Internal modules, certification and non-specification compliant operation

8.2 UART Interface

This is a standard UART interface for communicating with other serial devices.

CSR8675 BGA UART interface provides a simple mechanism for communicating with other serial devices using the RS-232 protocol.

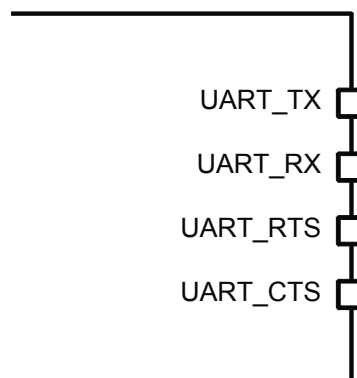

Figure 8.1: Universal Asynchronous Receiver Transmitter (UART)

Figure 8.1 shows the 4 signals that implement the UART function. When CSR8675 BGA is connected to another digital device, UART_RX and UART_TX transfer data between the 2 devices. The remaining 2 signals, UART_CTS and UART_RTS, implement RS232 hardware flow control where both are active low indicators.

If UART_CTS and UART_RTS are not required for hardware flow control, they are reconfigurable as PIO.

UART configuration parameters, such as baud rate and packet format, are set using CSR8675 BGA firmware.

Note:

To communicate with the UART at its maximum data rate using a standard PC, an accelerated serial port adapter card is required for the PC.

Table 8.1 shows the possible UART settings.

Parameter		Possible Values
Baud rate	Minimum	1200 baud ($\leq 2\%$ Error)
	Maximum	9600 baud ($\leq 1\%$ Error)
Flow control		RTS/CTS or None
Parity		None, Odd or Even
Number of stop bits		1 or 2
Bits per byte		8

Table 8.1: Possible UART Settings

The UART interface resets CSR8675 BGA on reception of a break signal. A break is identified by a continuous logic low (0V) on the UART_RX terminal, as Figure 8.2 shows. If t_{BRK} is longer than the value defined by the PSKEY_HOSTIO_UART_RESET_TIMEOUT, a reset occurs. This feature enables a host to initialise the system to a known state. Also, CSR8675 BGA can issue a break character for waking the host.

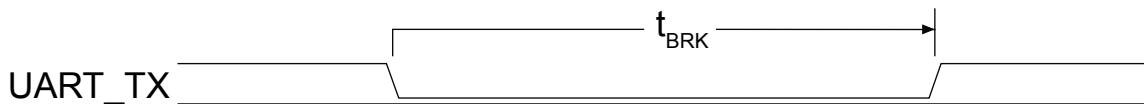

G-TW-0000250.5.2

Figure 8.2: Break Signal

Refer to PSKEY_UART_BITRATE for more information about the baud rates and their values.

Generated baud rate is independent of selected incoming clock frequency.

8.2.1 UART Configuration While Reset is Active

The UART interface is tristate while CSR8675 BGA is being held in reset. This enables the user to connect other devices onto the physical UART bus. The restriction with this method is that any devices connected to this bus must tristate when CSR8675 BGA reset is de-asserted and the firmware begins to run.

8.3 Programming and Debug Interface

Important Note:

The SPI is for programming, configuring (PS Keys) and debugging the CSR8675 BGA. It is required in production. Ensure the 4 SPI signals are brought out to either test points or a header.

CSR provides development and production tools to communicate over the SPI from a PC, although a level translator circuit is often required. All are available from CSR.

CSR8675 BGA uses a 16-bit data and 16-bit address programming and debug interface. Transactions occur when the internal processor is running or is stopped.

Data is written or read one word at a time, or the auto-increment feature is available for block access.

8.3.1 Instruction Cycle

The CSR8675 BGA is the slave and receives commands on SPI_MOSI and outputs data on SPI_MISO. Table 8.2 shows the instruction cycle for a SPI transaction.

1	Reset the SPI interface	Hold SPI_CS# high for two SPI_CLK cycles
2	Write the command word	Take SPI_CS# low and clock in the 8-bit command
3	Write the address	Clock in the 16-bit address word
4	Write or read data words	Clock in or out 16-bit data word(s)
5	Termination	Take SPI_CS# high

Table 8.2: Instruction Cycle for a SPI Transaction

With the exception of reset, SPI_CS# must be held low during the transaction. Data on SPI_MOSI is clocked into the CSR8675 BGA on the rising edge of the clock line SPI_CLK. When reading, CSR8675 BGA replies to the master on SPI_MISO with the data changing on the falling edge of the SPI_CLK. The master provides the clock on SPI_CLK. Taking SPI_CS# high terminates the transaction.

Sending a command word and the address of a register for every time it is to be read or written is a significant overhead, especially when transferring large amounts of data. To overcome this CSR8675 BGA offers increased data transfer efficiency via an auto increment operation. To invoke auto increment, SPI_CS# is kept low, which auto increments the address, while providing an extra 16 clock cycles for each extra word to be written or read.

8.3.2 Multi-slave Operation

Avoid connecting CSR8675 BGA in a multi-slave arrangement by simple parallel connection of slave MISO lines. When CSR8675 BGA is deselected (SPI_CS# = 1), the SPI_MISO line does not float. Instead, CSR8675 BGA outputs 0 if the processor is running or 1 if it is stopped.

8.3.3 SPI-lock

CSR8675 BGA contains an SPI-lock security feature to prevent unauthorised access to CSR8675 BGA and its firmware.

Warranty:

- While exercising all reasonable care and diligence in the design of the SPI-lock feature, CSR does not warrant its functionality. CSR disclaims any liability arising out of the SPI-lock feature to the maximum extent permitted by law.

8.4 I²C Interface

CSR8675 BGA contains a configurable hardware I²C interface. For more information contact CSR.

Note:

CSR8675 BGA supports a software I²C interface for low speed functions, including driving a dot matrix LCD, keyboard scanner or EEPROM.

9 Interfaces

9.1 Programmable I/O Ports, PIO

CSR8675 BGA provides 32 lines of programmable bidirectional I/O, PIO[31:0]. Some of the PIOs on the CSR8675 BGA have alternative functions, see Table 9.1.

PIO	Function				
	PCM	IPS	SPI Flash	UART	LED
PIO[31]	-	-	-	-	LED[1]
PIO[30]	-	-	-	-	LED[0]
PIO[29]	-	-	-	-	LED[2]
PIO[28]	-	-	QSPI_FLASH_IO[3]	-	-
PIO[27]	-	-	QSPI_FLASH_IO[2]	-	-
PIO[26]	-	-	QSPI_FLASH_IO[1]	-	-
PIO[25]	-	-	QSPI_FLASH_IO[0]	-	-
PIO[24]	-	-	QSPI_SRAM_CS#	-	-
PIO[23]	-	-	QSPI_FLASH_CS#	-	-
PIO[22]	-	-	QSPI_SRAM_CLK	-	-
PIO[21]	-	-	QSPI_FLASH_CLK	-	-
PIO[20]	PCM1_CLK	SCK1	-	-	-
PIO[19]	PCM1_SYNC	WS1	-	-	-
PIO[18]	PCM1_OUT	SD1_OUT	-	-	-
PIO[17]	PCM1_IN	SD1_IN	-	-	-
PIO[16]	-	-	-	UART_RTS	-
PIO[15:8]	-	-	-	-	-
PIO[7]	PCM2_CLK	SCK2	-	-	-
PIO[6]	PCM2_SYNC	WS2	-	-	-
PIO[5]	PCM2_OUT	SD2_OUT	-	-	-
PIO[4]	PCM2_IN	SD2_IN	-	-	-
PIO[3:0]	-	-	-	-	-

Table 9.1: Alternative PIO Functions

Note:

The SPDIF interface is available on any unused PIO. The data output (SPDIF_OUT) is restricted to even numbered PIO, and the data input (SPDIF_IN) is restricted to odd numbered PIO.

See the relevant software release note for the implementation of these PIO lines, as they are firmware build-specific.

9.2 Analogue I/O Ports, AIO

CSR8675 BGA has 2 general-purpose analogue interface pins, AIO[1:0], for accessing internal circuitry and control signals. Auxiliary functions available on the analogue interface include a 10-bit ADC and a 10-bit DAC. Signals selectable on this interface include the band gap reference voltage. When configured for analogue signals the voltage range is constrained by the analogue supply voltage. When configured to drive out digital level signals generated from within the analogue part of the device, the output voltage level is determined by VDD_AUX.

9.3 Capacitive Touch Sensor

CSR8675 BGA capacitive touch sensor interface features:

- Support for up to 6 capacitive touch sensing electrodes:
 - Printed on the PCB
 - Made from flex PCB
- Configuration for individual buttons
- Configuration for a wipe-type arrangement where 2 or more pads sense taps at each end or a wipe from one side to the other
- Operates in deep sleep and is a programmable source for wake-up

Figure 9.1 shows the system block diagram for the capacitive touch sensor interface. The interface depends on the capacitive touch sensor type. Therefore the overall control of the capacitive touch sensor interface resides in the VM, so it is easily modified in each end-user application.

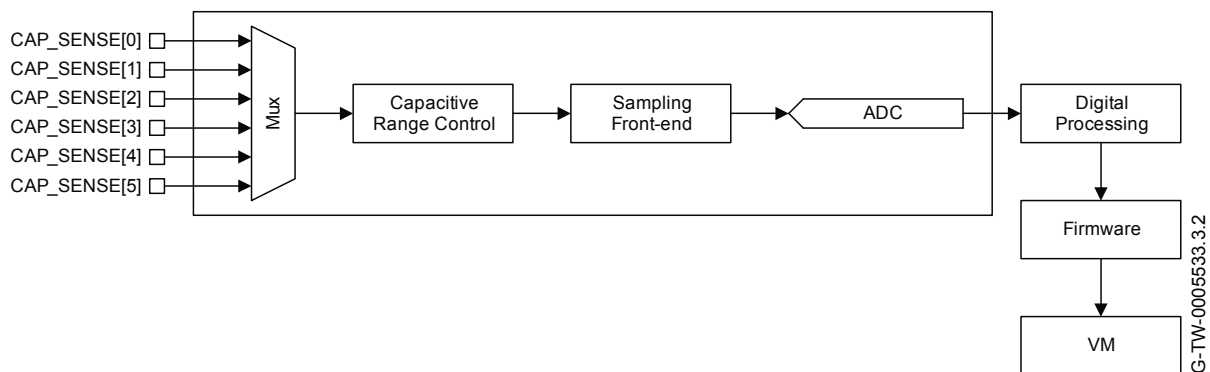

Figure 9.1: Capacitive Touch Sensor Block Diagram

The overall system-level specification for the capacitive touch sensor interface on the CSR8675 BGA is:

- 6 inputs multiplexed in to 1 touch sensor on the front-end
- Capacitances of 0 pF to 50 pF measured with a resolution of 4fF, where a touch is assumed to be between ± 50 fF and ± 1 pF
- Each reading takes 172 μ s:
 - 6 pads read every 1.03 ms
- System auto-calibrates to remove parasitic and environmental effects including:
 - PCB construction
 - Temperature
 - Humidity
- Works in normal and deep sleep modes
- System current is approximately 50 μ A from the battery
- The touch sensor also functions like a PIO

Figure 9.1 shows the system block diagram, it highlights the top-level architecture for the capacitive touch sensor interface and consists of:

- Capacitive range control, see Section 9.3.1
- Sampling front end, see Section 9.3.2
- ADC, see Section 9.3.3
- Digital signal conditioning (digital processing), see Section 9.3.4
- Software signal conditioning (firmware), see Section 9.3.5
- VM, see Section 9.3.6

For more information on CSR8675 BGA capacitive touch sensor configuration see *Configuring the Touch Sensor on CSR867x*.

9.3.1 Capacitive Range Control:

Figure 9.1 shows the capacitive range control function:

- Sets the rough capacitance of the touch sensor pad, which is product dependent
- Splits into 4 integrated capacitors
- The VM selects which capacitors are enabled, i.e. the range capacitance

9.3.2 Sampling Front End

Figure 9.1 shows the sampling front end function:

- An internal capacitance is trimmed by the digital state machine ensuring:
 - Touch Capacitance = Range Capacitance + Internal Capacitance
- When the internal capacitance is correctly trimmed:
 - The sense voltage is 0 V
 - A touch changes the touch capacitance, which then changes the sense voltage

9.3.3 ADC

Figure 9.1 shows the ADC:

- Uses a successive approximation, charge redistribution ADC
- Clocked at 64 kHz
- 9-bit resolution, where LSB is ± 2 fF and full range is ± 1 pF
- The internal capacitance is a 7-bit variable capacitor with 114 fF steps and 14.5 pF range
- The internal capacitance is trimmed, putting it in the mid range of the ADC. This enables measurements from 0 pF to 50 pF, where a capacitive touch is between ± 50 fF and ± 1 pF.

9.3.4 Digital Signal Conditioning (Digital Processing)

Figure 9.1 shows the digital processing block which is responsible for digital signal conditioning:

- Only the enabled inputs are scanned
- Enabling fewer inputs increases readings per second
- Averaging of ADC readings reduces noise, this is software programmable from 1 to 64 readings in intervals to the power of 2
- The internal capacitance updates using a rolling average of the ADC readings, software programmable from 1 to 2^{15} readings in intervals to the power of 2. For example, 32768 readings take approximately:
 - 5.6 s if polling one pad (no averaging)
 - 33.8 s if polling 6 pads (no averaging)
- Pulse skipping mode is possible, reducing the current consumption. Here the system waits a programmable number of 64 kHz clock cycles (maximum 2^9) before the next read, i.e. an 8 ms maximum pause.
- ADC trigger level is software programmable. If the threshold is crossed the firmware gets an interrupt.
- 6 hardware event registers store the pad number and trigger time, which enables the system to sense swipes.
- Programmable hysteresis, with one value for all pads

9.3.5 Software Signal Conditioning (Firmware)

Figure 9.1 shows the firmware block which is responsible for software signal conditioning:

- The firmware reads ADC and C_{int} values after an interrupt as the hardware only stores the pad number and trigger time
- Digital state machine scans pads and calibrates the internal capacitance
- If a swipe happens in deep sleep the firmware reads the trigger order and event time when it wakes up. It then reads the last ADC reading for each input, not the reading that triggered the interrupt.

9.3.6 VM

Figure 9.1 shows the VM block for the capacitive touch sensor interface:

- Configures the hardware and gets an interrupt when a programmable threshold is crossed
- Selects the range capacitance
- Decides whether an event is a valid touch

9.4 LED Drivers

CSR8675 BGA includes a 3-pad synchronised PWM LED driver for driving RGB LEDs for producing a wide range of colours. All LEDs are controlled by firmware.

The terminals are open-drain outputs, so the LED must be connected from a positive supply rail to the pad in series with a current-limiting resistor.

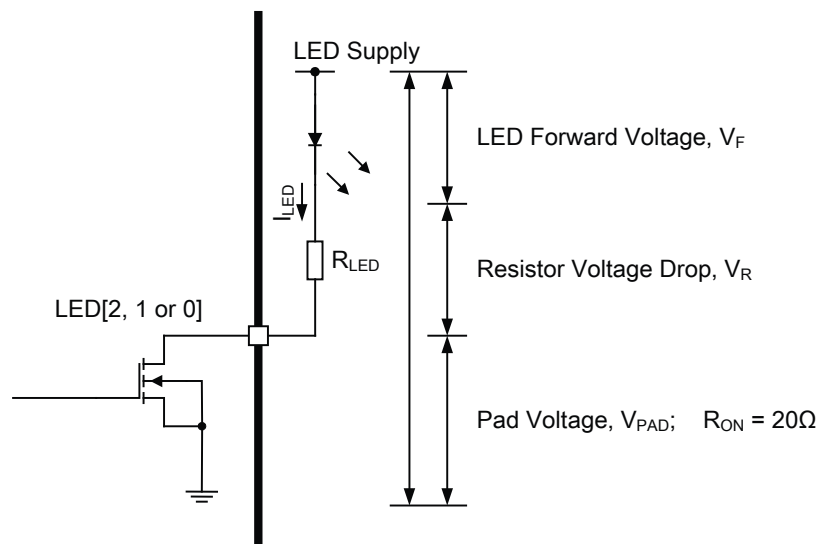

Figure 9.2: LED Equivalent Circuit

From Figure 9.2 it is possible to derive Equation 9.1 to calculate I_{LED} . If a known value of current is required through the LED to give a specific luminous intensity, then the value of R_{LED} is calculated.

$$I_{LED} = \frac{VDD - V_F}{R_{LED} + R_{ON}}$$

Equation 9.1: LED Current

For the LED pads to act as resistance, the external series resistor, R_{LED} , needs to be such that the voltage drop across it, V_R , keeps V_{PAD} below 0.5V. Equation 9.2 also applies.

$$VDD = V_F + V_R + V_{PAD}$$

Equation 9.2: LED PAD Voltage



Note:

The supply for domain in Section 1.2 for LED[2:0] must remain powered for LED functions to operate.
The LED current adds to the overall current. Conservative LED selection extends battery life.

10 Audio Interface

The audio interface circuit consists of:

- Stereo/dual-mono audio codec
- Dual analogue audio inputs
- Dual analogue audio outputs
- 6 digital MEMS microphone inputs
- 2 configurable PCM/I²S interfaces
- SPDIF interface

For more information on CSR8675 BGA audio path configuration see the CSR8675 Audio Development Kit (DK-CSR8675-10197-1A).

Figure 10.1 shows the functional blocks of the interface. The codec supports stereo/dual-mono playback and recording of audio signals at multiple sample rates with a 24-bit resolution. The ADC and the DAC of the codec each contain 2 independent high-quality channels. Any ADC or DAC channel runs at its own independent sample rate.

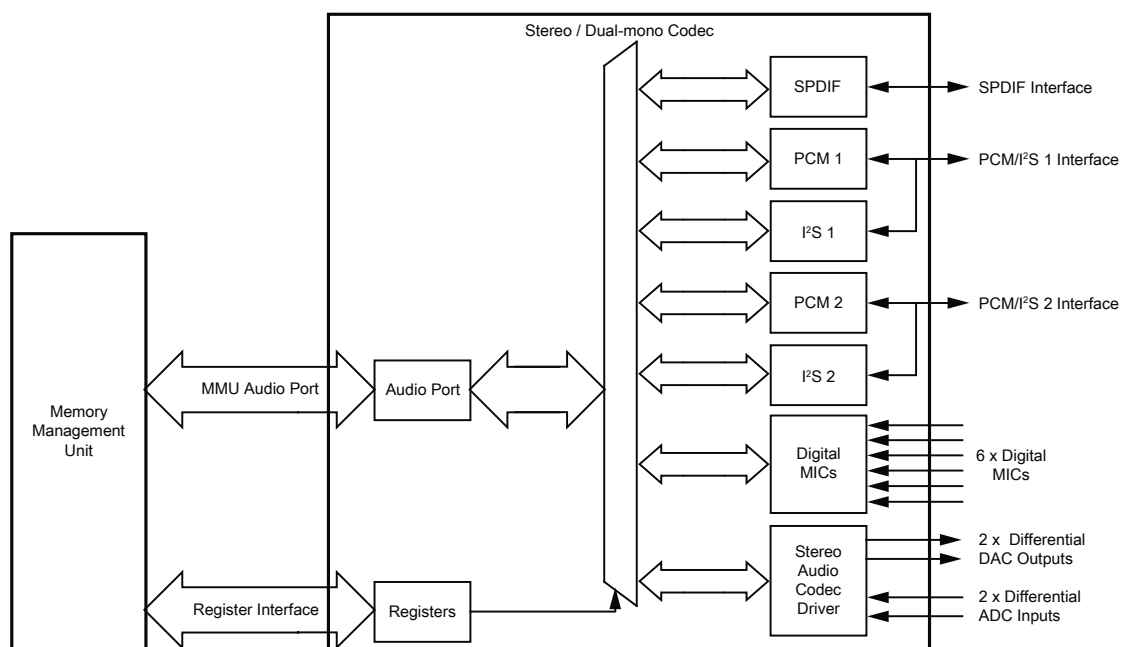

Figure 10.1: Audio Interface

CSR8675 BGA supports various digital audio bus interfaces:

- 2 configurable PCM/I²S interfaces:
 - PCM1 interface shares the same pins as I²S1 interface but the audio buses are mutually exclusive in their usage. Table 10.1 shows shared pins for the PCM/I²S 1 interface.
 - PCM2 interface shares the same pins as I²S2 interface but the audio buses are mutually exclusive in their usage. Table 10.1 shows shared pins for the PCM/I²S 2 interface.
- SPDIF interface which is available on any unused PIO. The data output (SPDIF_OUT) is restricted to even numbered PIO, and the data input (SPDIF_IN) is restricted to odd numbered PIO, see the relevant software release note for the implementation of these PIO lines, as they are firmware build-specific.

PIO	PCM Interface	I ² S Interface
PIO[20]	PCM1_CLK	SCK1
PIO[19]	PCM1_SYNC	WS1
PIO[18]	PCM1_OUT	SD1_OUT
PIO[17]	PCM1_IN	SD1_IN
PIO[7]	PCM2_CLK	SCK2
PIO[6]	PCM2_SYNC	WS2
PIO[5]	PCM2_OUT	SD2_OUT
PIO[4]	PCM2_IN	SD2_IN

Table 10.1: Shared Pins on PCM/I²S Interfaces

10.1 Audio Input and Output

The audio input circuitry consists of:

- 2 independent 24-bit high-quality ADC channels:
 - Programmable as either microphone or line input
 - Programmable as either stereo or dual-mono inputs
 - Multiplexed with 2 of the digital microphone inputs, see Section 10.2.16
 - Each channel is independently configurable to be either single-ended or fully differential
 - Each channel has an analogue and digital programmable gain stage for optimisation of different microphones
- 6 digital MEMS microphone channels, of which 4 have independent codec channels and 2 share their codecs with the 2 high-quality audio inputs

The audio output circuitry consists of a dual differential class A-B output stage.

Note:

CSR8675 BGA is designed for a differential audio output. If a single-ended audio output is required, use an external differential to single-ended converter.

10.2 Audio Codec Interface

The main features of the interface are:

- Stereo and mono analogue input for voice band and audio band
- Stereo and mono analogue output for voice band and audio band
- Support for up to 2 PCM interfaces including PCM master codecs that require an external system clock
- Support for up to 2 stereo I²S digital audio bus standard
- Support for IEC-60958 standard stereo digital audio bus standards, e.g. SPDIF and AES3 (also known as AES/EBU)

Important Note:

To avoid any confusion regarding stereo operation this data sheet explicitly states which is the left and right channel for audio output. With respect to audio input, software and any registers, channel 0 or channel A represents the left channel and channel 1 or channel B represents the right channel.

10.2.1 Audio Codec Block Diagram

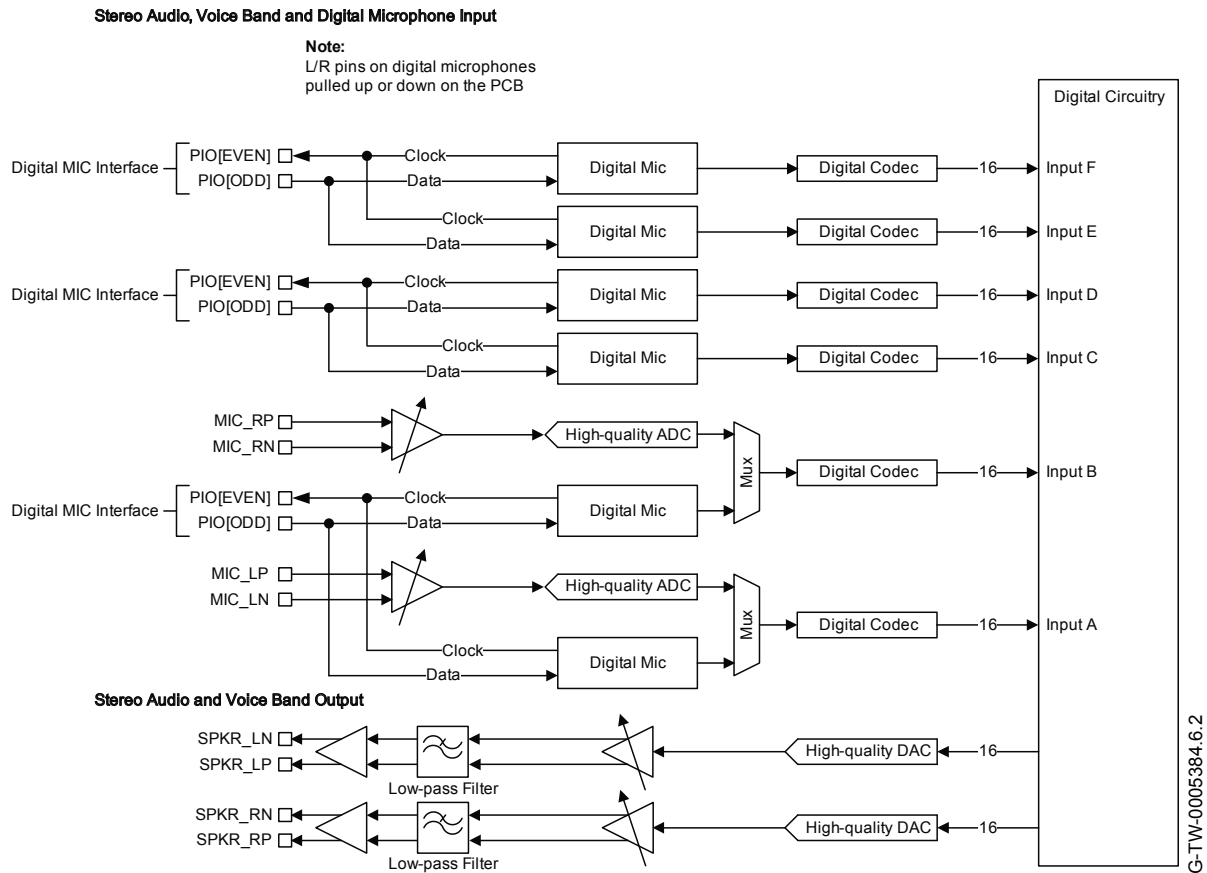

Figure 10.2: Audio Codec Input and Output Stages

The CSR8675 BGA audio codec uses a fully differential architecture in the analogue signal path, which results in low noise sensitivity and good power supply rejection while effectively doubling the signal amplitude. It operates from a dual power supply, VDD_AUDIO for the audio circuits and VDD_AUDIO_DRV for the audio driver circuits.

10.2.2 Codec Set-up

The configuration and control of the ADC is through software functions described in appropriate development kit documentation. This section is an overview of the parameters set up using the software functions.

The Kalimba DSP communicates its codec requirements to the MCU, and therefore also to the VM, by exchanging messages. Messages between the Kalimba DSP and the embedded MCU are based on interrupts:

- 1 interrupt between the MCU and Kalimba DSP
- 1 interrupt between the Kalimba DSP and the MCU

Message content is transmitted using shared memory. There are VM and DSP library functions to send and receive messages; see appropriate development kit documentation for further details.

10.2.3 ADC

Figure 10.2 shows the CSR8675 BGA consists of 2 high-quality ADCs:

- Each ADC has a second-order Sigma-Delta converter.
- Each ADC is a separate channel with identical functionality.
- There are 2 gain stages for each channel, 1 of which is an analogue gain stage and the other is a digital gain stage, see Section 10.2.5.

10.2.4 ADC Sample Rate Selection

Each ADC supports the following pre-defined sample rates, although other rates are programmable, e.g. 40 kHz:

- 8 kHz
- 11.025 kHz
- 16 kHz
- 22.050 kHz
- 24 kHz
- 32 kHz
- 44.1 kHz
- 48 kHz
- 96 kHz

10.2.5 ADC Audio Input Gain

Figure 10.3 shows that the CSR8675 BGA audio input gain consists of:

- An analogue gain stage based on a pre-amplifier and an analogue gain amplifier, see Section 10.2.6
- A digital gain stage, see Section 10.2.7

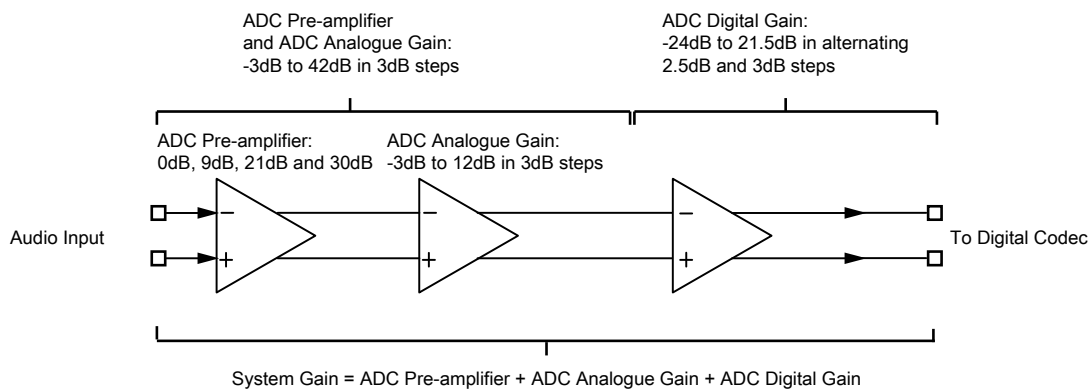

G-TW-0005535.4.3

Figure 10.3: Audio Input Gain

10.2.6 ADC Pre-amplifier and ADC Analogue Gain

CSR8675 BGA has an analogue gain stage based on an ADC pre-amplifier and ADC analogue amplifier:

- The ADC pre-amplifier has 4 gain settings: 0dB, 9dB, 21dB and 30dB
- The ADC analogue amplifier gain is -3dB to 12dB in 3dB steps
- The overall analogue gain for the pre-amplifier and analogue amplifier is -3dB to 42dB in 3dB steps, see Figure 10.3
- At mid to high gain levels it acts as a microphone pre-amplifier, see Section 10.2.15
- At low gain levels it acts as an audio line level amplifier

10.2.7 ADC Digital Gain

A digital gain stage inside the ADC varies from -24dB to 21.5dB, see Table 10.2. There is also a *fine gain interface* with a 9-bit gain setting allowing gain changes in 1/32 steps, for more information contact CSR.

The firmware controls the audio input gain.

Digital Gain Selection Value	ADC Digital Gain Setting (dB)	Digital Gain Selection Value	ADC Digital Gain Setting (dB)
0	0	8	-24
1	3.5	9	-20.5
2	6	10	-18
3	9.5	11	-14.5
4	12	12	-12
5	15.5	13	-8.5
6	18	14	-6
7	21.5	15	-2.5

Table 10.2: ADC Audio Input Gain Rate

10.2.8 ADC Digital IIR Filter

The ADC contains 2 integrated anti-aliasing filters:

- A *default* IIR filter suitable for music (>44.1kHz)
- G.722 filter is a digital IIR filter that improves the stop-band attenuation required for G.722 compliance (which is the best selection for 8kHz / 16kHz / voice)

For more information contact CSR.

10.2.9 DAC

The DAC consists of:

- 2 fourth-order Sigma-Delta converters enabling 2 separate channels that are identical in functionality, as Figure 10.2 shows.
- 2 gain stages for each channel, 1 of which is an analogue gain stage and the other is a digital gain stage.

10.2.10 DAC Sample Rate Selection

Each DAC supports the following sample rates:

- 8 kHz
- 11.025 kHz
- 16 kHz
- 22.050 kHz
- 32 kHz
- 40 kHz
- 44.1 kHz
- 48 kHz
- 96 kHz
- 192 kHz

10.2.11 DAC Digital Gain

A digital gain stage inside the DAC varies from -24dB to 21.5dB, see Table 10.3. There is also a *fine gain interface* with a 9-bit gain setting enabling gain changes in 1/32 steps, for more information contact CSR.

The overall gain control of the DAC is controlled by the firmware. Its setting is a combined function of the digital and analogue amplifier settings.

Digital Gain Selection Value	DAC Digital Gain Setting (dB)	Digital Gain Selection Value	DAC Digital Gain Setting (dB)
0	0	8	-24
1	3.5	9	-20.5
2	6	10	-18
3	9.5	11	-14.5
4	12	12	-12
5	15.5	13	-8.5
6	18	14	-6
7	21.5	15	-2.5

Table 10.3: DAC Digital Gain Rate Selection

10.2.12 DAC Analogue Gain

Table 10.4 shows that the DAC analogue gain stage consists of 8 gain selection values that represent seven 3dB steps. The firmware controls the overall gain control of the DAC. Its setting is a combined function of the digital and analogue amplifier settings.

Analogue Gain Selection Value	DAC Analogue Gain Setting (dB)	Analogue Gain Selection Value	DAC Analogue Gain Setting (dB)
7	0	3	-12
6	-3	2	-15
5	-6	1	-18
4	-9	0	-21

Table 10.4: DAC Analogue Gain Rate Selection

10.2.13 DAC Digital FIR Filter

The DAC contains an integrated digital FIR filter with the following modes:

- A default *long* FIR filter for best performance at ≥ 44.1 kHz.
- A *short* FIR to reduce latency.
- A *narrow* FIR (a very sharp roll-off at Nyquist) for G.722 compliance. Best for 8kHz / 16kHz.

10.2.14 IEC 60958 Interface

The IEC 60958 interface is a digital audio interface that uses bi-phase coding to minimise the DC content of the transmitted signal and enables the receiver to decode the clock information from the transmitted signal. The IEC 60958 specification is based on the 2 industry standards:

- AES3 (also known as AES/EBU)
- Sony and Philips interface specification SPDIF

The interface is compatible with IEC 60958-1, IEC 60958-3 and IEC 60958-4.

The SPDIF interface signals, SPDIF_IN and SPDIF_OUT, interface to:

- A 75Ω coaxial cable with an RCA connector, see Figure 10.4
- An optical link that uses Toslink optical components, see Figure 10.5.

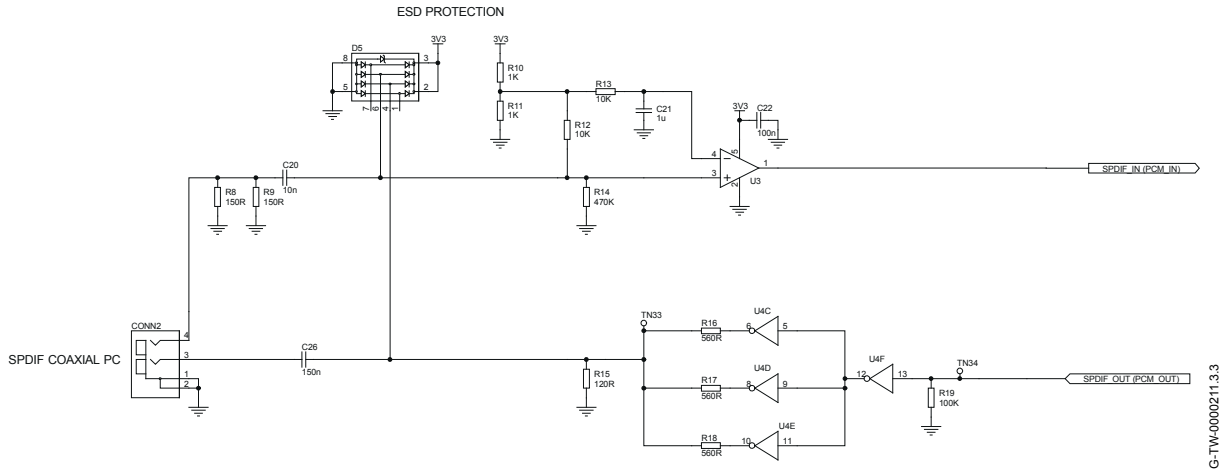

Figure 10.4: Example Circuit for SPDIF Interface (Co-axial)

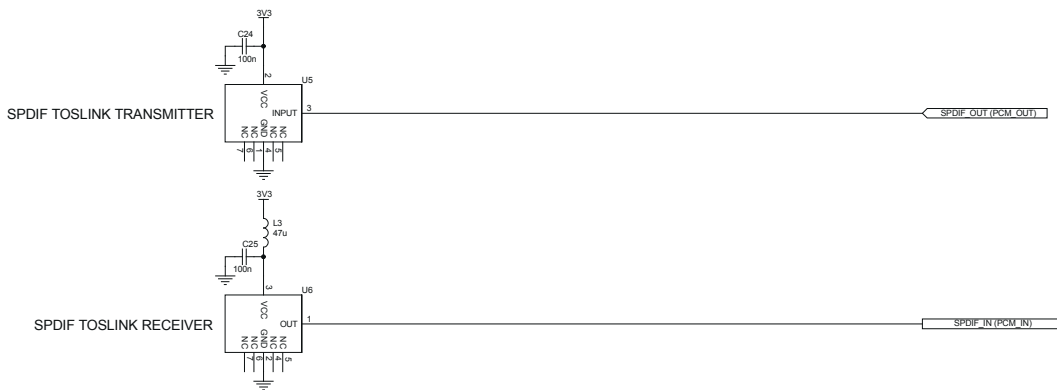

Figure 10.5: Example Circuit for SPDIF Interface (Optical)

10.2.15 Microphone Input

CSR8675 BGA contains 2 independent low-noise microphone bias generators. The microphone bias generators are recommended for biasing electret condenser microphones. Figure 10.6 shows a biasing circuit for microphones with a sensitivity between about -40 to -60dB (0dB = 1V/Pa).

Where:

- The microphone bias generators derive their power from VBAT (via SMP_VBAT) or VOUT_3V3 (via SMPS_3V3) and require no capacitor on their output.
- The microphone bias generators maintain regulation within the limits 70µA to 2.8mA, supporting a 2mA source typically required by 2 electret condenser microphones. If the microphone sits below these limits, then the microphone output must be pre-loaded with a large value resistor to ground.
- Biasing resistors R1 and R2 equal 2.2kΩ.
- When the input pre-amplifier is enabled, the input impedance at MIC_LN, MIC_LP, MIC_RN and MIC_RP varies between 6kΩ (pre-amplifier gain >0dB) and 12kΩ (pre-amplifier gain = 0dB).
- C1, C2, C3 and C4 are 100/150nF if bass roll-off is required to limit wind noise on the microphone.
- R1 and R2 set the microphone load impedance and are normally around 2.2kΩ.

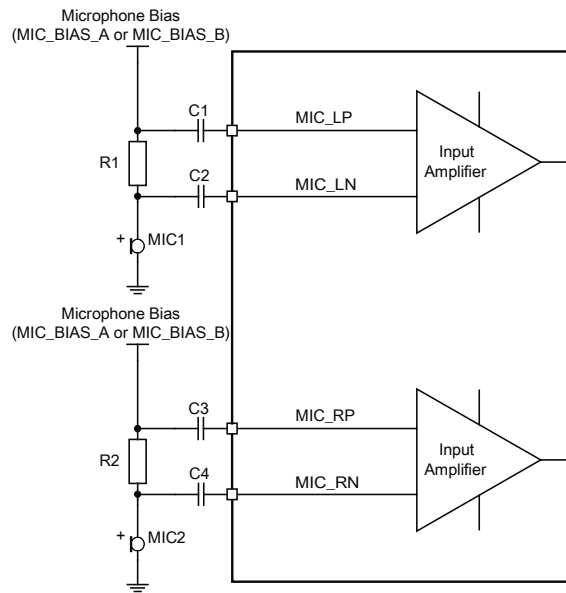

Figure 10.6: Microphone Biasing

The microphone bias characteristics include:

- Power supply:
 - CSR8675 BGA microphone supply is VBAT (via SMP_VBAT) or VOUT_3V3 (via SMPS_3V3)
 - Minimum input voltage = Output voltage + drop-out voltage
 - Maximum input voltage is 4.3V
- Drop-out voltage:
 - 300mV maximum
- Output voltage:
 - 1.8V or 2.6V
 - Tolerance 90% to 110%
- Output current:
 - 70µA to 2.8mA
- No load capacitor required

10.2.16 Digital Microphone Inputs

The CSR8675 BGA interfaces to 6 digital MEMS microphones. Figure 10.2 shows that 4 of the inputs have dedicated codec channels and 2 are multiplexed with the high-quality ADC channels.

Figure 10.2 shows that the digital microphone interface on the CSR8675 BGA has:

- Clock lines shared between 2 microphone outputs, linked to any even-numbered PIO pin as determined by the firmware.

Note:

Multiple digital microphones can share the same clock if they are configured for the same frequency, e.g. 1 clock for 6 digital microphones.

- Data lines shared between 2 microphone inputs, linked to any odd-numbered PIO as determined by the firmware.

Note:

For the digital microphone interface to work in this configuration ensure the microphone uses a tristate between edges.

- The left and right selection for the digital microphones are appropriately pulled up or down for selection on the PCB.

G-TW-0005536.3.2

10.2.17 Line Input

Figure 10.7 and Figure 10.8 show 2 circuits for line input operation and show connections for either differential or single-ended inputs.

In line input mode, the input impedance of the pins to ground varies from 6kΩ to 34kΩ depending on input gain setting.

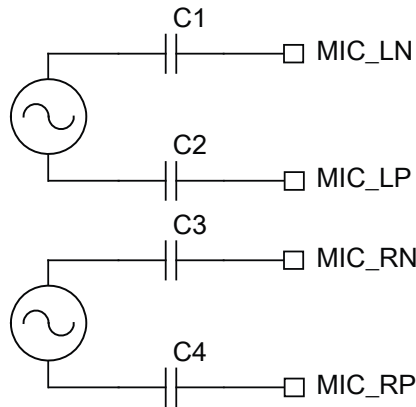

Figure 10.7: Differential Input

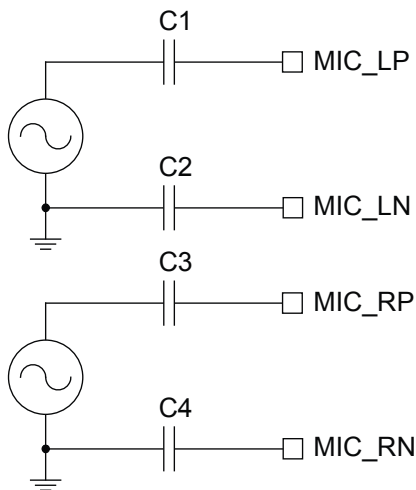

Figure 10.8: Single-ended Input

10.2.18 Output Stage

The output stage digital circuitry converts the signal from linear PCM of variable sampling frequency to bit stream, which is fed into the analogue output circuitry.

The analogue output circuit comprises a DAC, a buffer with gain-setting, a low-pass filter and a class AB output stage amplifier. Figure 10.9 shows that the output is available as a differential signal between SPKR_LN and SPKR_LP for the left channel, and between SPKR_RN and SPKR_RP for the right channel.

G-TW-0005511.2.2

G-TW-0005512.2.2

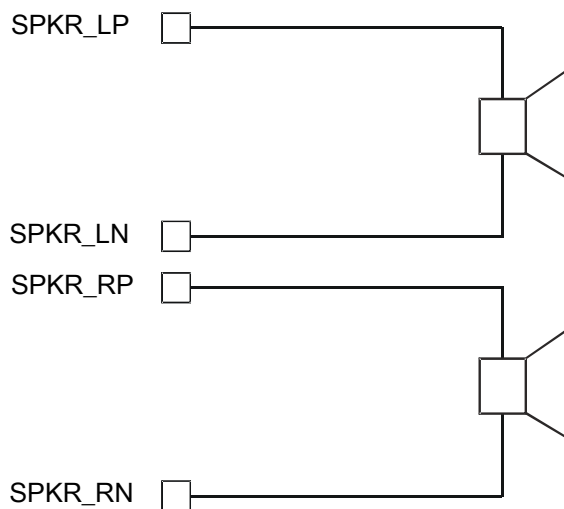

Figure 10.9: Speaker Output

10.2.19 Mono Operation

Mono operation is a single-channel operation of the stereo codec. The left channel represents the single mono channel for audio in and audio out. In mono operation, the right channel is the auxiliary mono channel for dual-mono channel operation.

In single channel mono operation, disable the other channel to reduce power consumption.

G-TW-0005637.1.1

10.2.20 Side Tone

In some applications it is necessary to implement side tone. This side tone function involves feeding a properly gained microphone signal in to the DAC stream, e.g. earpiece. The side tone routing selects the version of the microphone signal from before or after the digital gain in the ADC interface and adds it to the output signal before or after the digital gain of the DAC interface, see Figure 10.10.

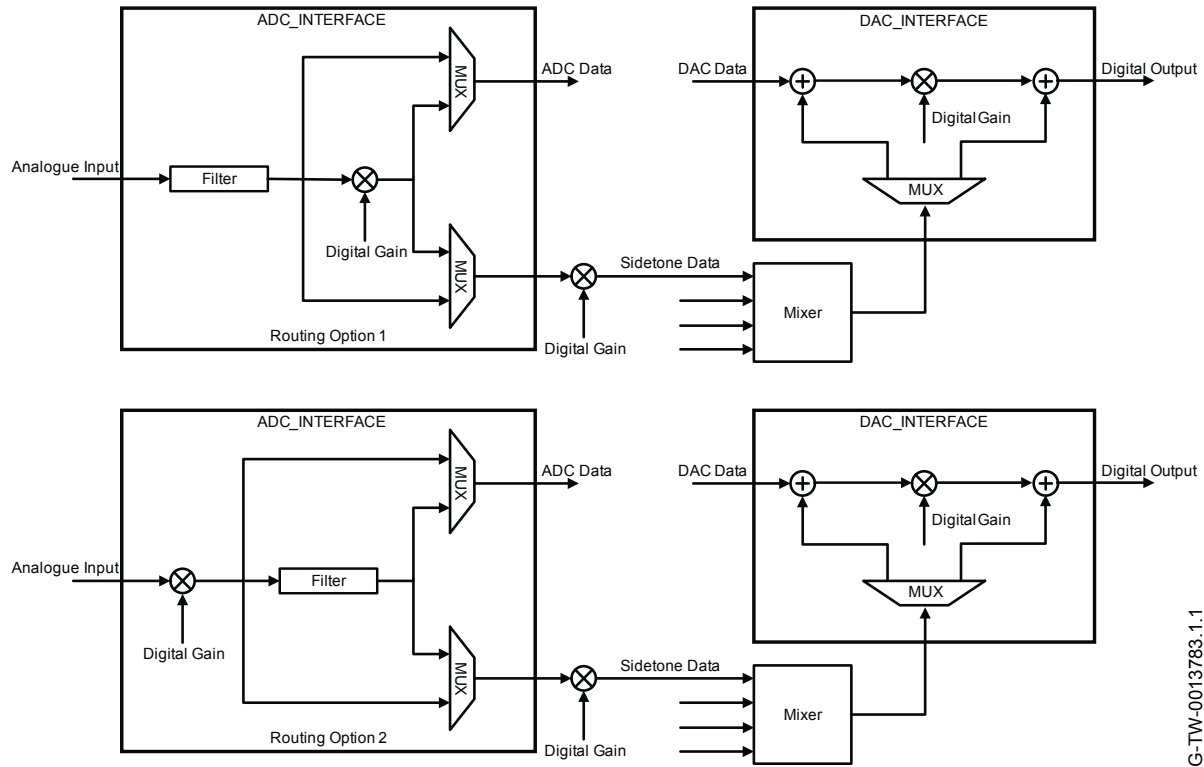

Figure 10.10: Side Tone

The ADC provides simple gain to the side tone data. The gain values range from -32.6dB to 12.0dB in alternating steps of 2.5dB and 3.5dB, see Table 10.5.

Value	Side Tone Gain	Value	Side Tone Gain
0	-32.6dB	8	-8.5dB
1	-30.1dB	9	-6.0dB
2	-26.6dB	10	-2.5dB
3	-24.1dB	11	0dB
4	-20.6dB	12	3.5dB
5	-18.1dB	13	6.0dB
6	-14.5dB	14	9.5dB
7	-12.0dB	15	12.0dB

Table 10.5: Side Tone Gain

Note:

The values of side tone are shown for information only. During standard operation, the application software controls the side tone gain.

The following PS Keys configure the side tone hardware:

- PSKEY_SIDE_TONE_ENABLE
- PSKEY_SIDE_TONE_GAIN
- PSKEY_SIDE_TONE_AFTER_ADC
- PSKEY_SIDE_TONE_AFTER_DAC

10.2.21 Integrated Digital IIR Filter

CSR8675 BGA has a programmable digital filter integrated into the ADC channel of the codec. The filter is a 2-stage, second order IIR and is for functions such as custom wind noise reduction. The filter also has optional DC blocking.

The filter has 11 configuration words:

- 2 for gain values
- 8 for coefficient values
- 1 for enabling and disabling the DC blocking

The gain and coefficients are all 12-bit 2's complement signed integer with the format `NN.NNNNNNNNNN`.

Note:

The position of the binary point is between bit[10] and bit[9], where bit[11] is the most significant bit.

For example:

```
01.1111111111 = most positive number, close to 2
01.0000000000 = 1
00.0000000000 = 0
11.0000000000 = -1
10.0000000000 = -2, most negative number
```

Equation 10.1 shows the equation for the IIR filter. Equation 10.2 shows the equation for when the DC blocking is enabled.

The filter is configured, enabled and disabled from the VM via the `CodecSetIIRFilter` trap. This requires firmware support. The configuration function takes 11 variables in the following order:

- 0 : Gain₀ and Exp₀
- 1 : b₀₁
- 2 : b₀₂
- 3 : a₀₁
- 4 : a₀₂

- 5 : Gain₁
- 6 : b₁₁
- 7 : b₁₂
- 8 : a₁₁
- 9 : a₁₂
- a : DC Block (1 = enable, 0 = disable)

$$\text{Filter, } H(z) = (1 - z^{-1}) \times 2^{\text{Exp}_0} \times \text{Gain}_0 \times \left(\frac{1 + b_{01} z^{-1} + b_{02} z^{-2}}{1 + a_{01} z^{-1} + a_{02} z^{-2}} \right) \times \text{Gain}_1 \times \left(\frac{1 + b_{11} z^{-1} + b_{12} z^{-2}}{1 + a_{11} z^{-1} + a_{12} z^{-2}} \right)^{\text{Exp}_0}$$

Equation 10.1: IIR Filter Transfer Function, H(z)

$$\text{Filter with DC Blocking, } H_{\text{DC}}(z) = H(z) \times (1 - z^{-1})$$

Equation 10.2: IIR Filter Plus DC Blocking Transfer Function, H_{DC}(z)

10.3 PCM1 and PCM2 Interface

Important Note:

The term *PCM* in Section 10.3 and its subsections, Section 10.3.1 to Section 10.3.10, refers to PCM1 and PCM2 interfaces.

The PCM interface shares the same pins as I²S interface but the audio buses are mutually exclusive in their usage. Section 10.3 shows shared pins for the PCM/I²S interface.

The audio PCM interface on the CSR8675 BGA supports:

- On-chip routing to Kalimba DSP
- Continuous transmission and reception of PCM encoded audio data over Bluetooth.
- Processor overhead reduction through hardware support for continual transmission and reception of PCM data
- A bidirectional digital audio interface that routes directly into the baseband layer of the firmware. It does not pass through the HCI protocol layer.
- Hardware on the CSR8675 BGA for sending data to and from a SCO connection.
- Up to 3 SCO connections on the PCM interface at any one time.
- PCM interface master, generating PCM_SYNC and PCM_CLK.
- PCM interface slave, accepting externally generated PCM_SYNC and PCM_CLK.
- Various clock formats including:
 - Long Frame Sync
 - Short Frame Sync
 - GCI timing environments
- 24-bit / 16-bit / 13-bit linear, 8-bit μ-law or A-law companded sample formats.
- Receives and transmits on any selection of 3 of the first 4 slots following PCM_SYNC.

The PCM configuration options are enabled by setting the PS Key PSKEY_PCM_CONFIG32.

10.3.1 PCM Interface Master/Slave

When configured as the master of the PCM interface, CSR8675 BGA generates PCM_CLK and PCM_SYNC.

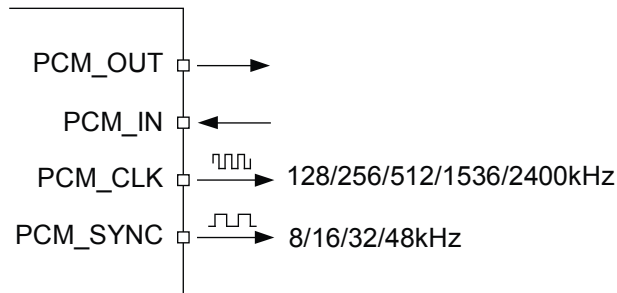

Figure 10.11: PCM Interface Master

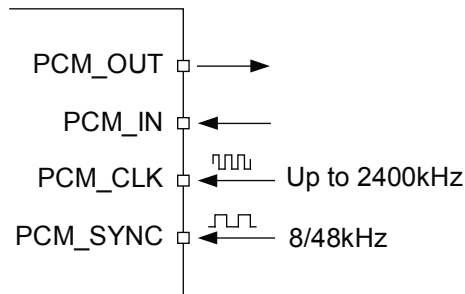

Figure 10.12: PCM Interface Slave

10.3.2 Long Frame Sync

Long Frame Sync is the name given to a clocking format that controls the transfer of PCM data words or samples. In Long Frame Sync, the rising edge of PCM_SYNC indicates the start of the PCM word. When CSR8675 BGA is configured as PCM master, generating PCM_SYNC and PCM_CLK, then PCM_SYNC is 8 bits long. When CSR8675 BGA is configured as PCM Slave, PCM_SYNC is from 1 cycle PCM_CLK to half the PCM_SYNC rate.

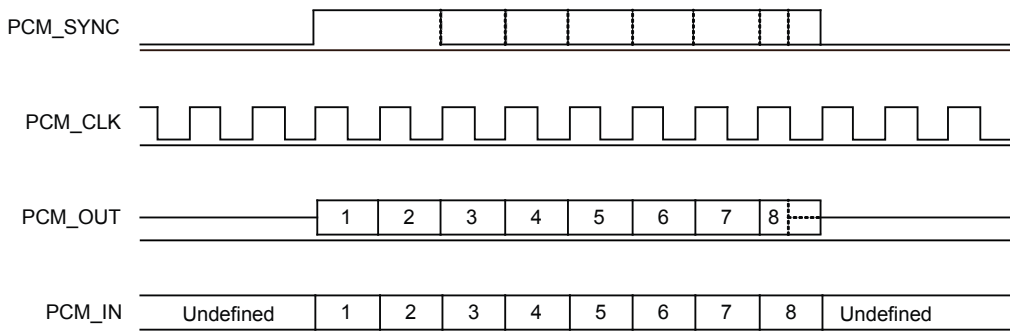
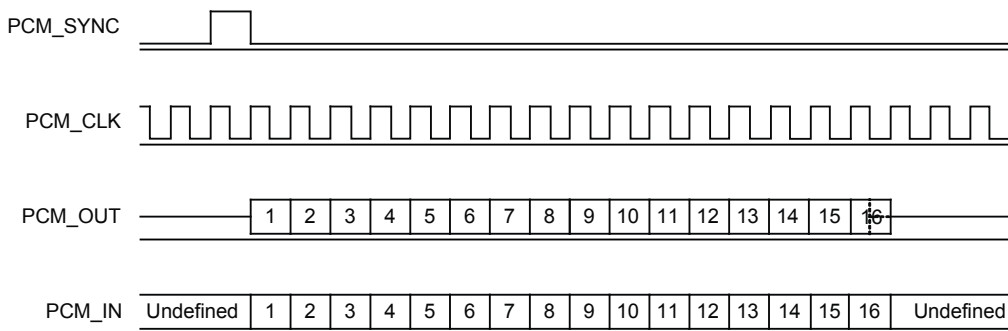

Figure 10.13: Long Frame Sync (Shown with 8-bit Companded Sample)

CSR8675 BGA samples PCM_IN on the falling edge of PCM_CLK and transmits PCM_OUT on the rising edge. PCM_OUT is configurable as high impedance on the falling edge of PCM_CLK in the LSB position or on the rising edge.

10.3.3 Short Frame Sync

In Short Frame Sync, the falling edge of PCM_SYNC indicates the start of the PCM word. PCM_SYNC is always 1 clock cycle long.



G-TW-0000220.2.3

Figure 10.14: Short Frame Sync (Shown with 16-bit Sample)

As with Long Frame Sync, CSR8675 BGA samples PCM_IN on the falling edge of PCM_CLK and transmits PCM_OUT on the rising edge. PCM_OUT is configurable as high impedance on the falling edge of PCM_CLK in the LSB position or on the rising edge.

10.3.4 Multi-slot Operation

More than 1 SCO connection over the PCM interface is supported using multiple slots. Up to 3 SCO connections are carried over any of the first 4 slots.

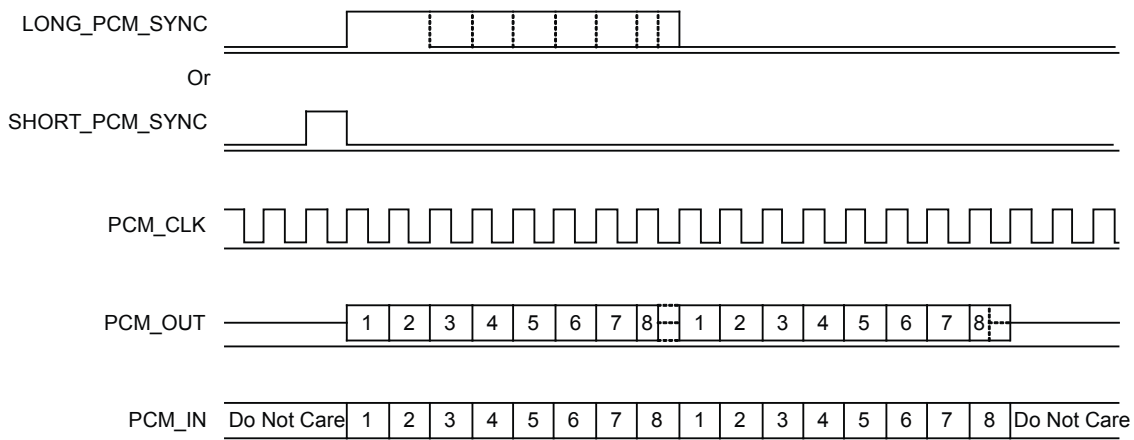

G-TW-0000221.3.2

Figure 10.15: Multi-slot Operation with 2 Slots and 8-bit Companded Samples

10.3.5 GCI Interface

CSR8675 BGA is compatible with the GCI, a standard synchronous 2B+D ISDN timing interface. The 2 64kbps B channels are accessed when this mode is configured.

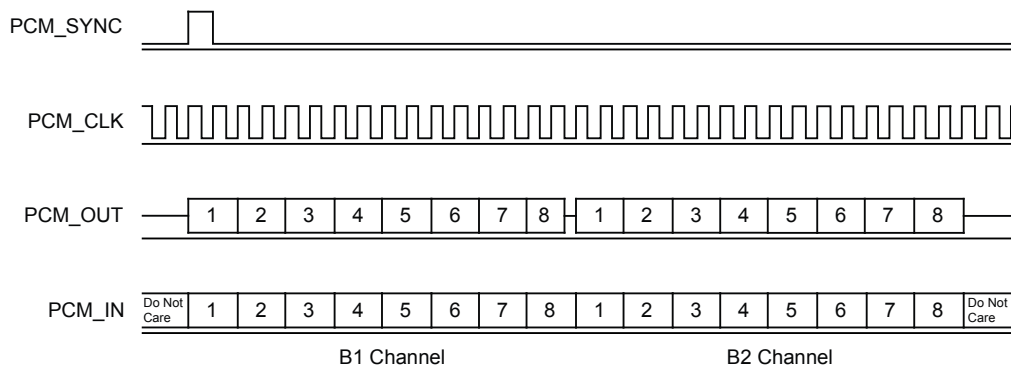

G-TW-0000222.2.3

Figure 10.16: GCI Interface

The start of frame is indicated by the rising edge of PCM_SYNC and typically runs at 8kHz/16kHz.

10.3.6 Slots and Sample Formats

CSR8675 BGA receives and transmits on any selection of the first 4 slots following each sync pulse. Slot durations are either 8 or 16 clock cycles:

- 8 clock cycles for 8-bit sample formats.
- 16 clocks cycles for 8-bit, 13-bit or 16-bit sample formats.

CSR8675 BGA supports:

- 13-bit linear, 16-bit linear and 8-bit μ -law or A-law sample formats.
- A sample rate of 8ksamples/s, 16ksamples/s or 32ksamples/s.
- Little or big endian bit order.
- For 16-bit slots, the 3 or 8 unused bits in each slot are filled with sign extension, padded with zeros or a programmable 3-bit audio attenuation compatible with some codecs.

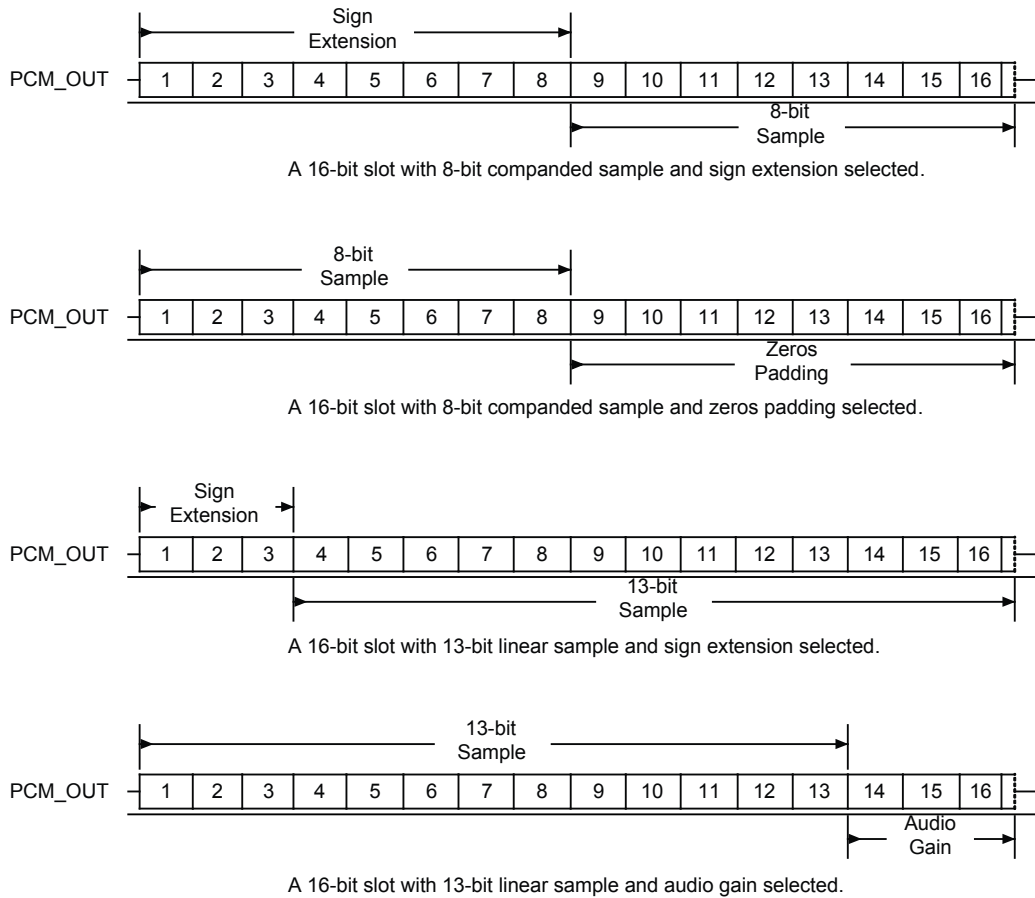

G-TW-0000223.2.3

Figure 10.17: 16-bit Slot Length and Sample Formats

10.3.7 Additional Features

CSR8675 BGA has a mute facility that forces PCM_OUT to be 0. In master mode, CSR8675 BGA is compatible with some codecs which control power down by forcing PCM_SYNC to 0 while keeping PCM_CLK running.

10.3.8 PCM Timing Information

Symbol	Parameter	Min	Typ	Max	Unit
f_{mclk}	PCM_CLK frequency	-	128	-	kHz
			256		
	4MHz DDS generation. Selection of frequency is programmable. See Section 10.3.10.		512		
	48MHz DDS generation. Selection of frequency is programmable. See Section 10.3.10.	2.9	-	-	kHz
-	PCM_SYNC frequency for SCO connection	-	8	-	kHz
$t_{mclkh}^{(a)}$	PCM_CLK high	980	-	-	ns

Symbol	Parameter		Min	Typ	Max	Unit
$t_{mclk}^{(a)}$	PCM_CLK low	4MHz DDS generation	730	-	-	ns
-	PCM_CLK jitter	48MHz DDS generation	-	-	21	ns pk-pk
$t_{dmclk\sync}$	Delay time from PCM_CLK high to PCM_SYNC high		-	-	20	ns
$t_{dmclk\pout}$	Delay time from PCM_CLK high to valid PCM_OUT		-	-	20	ns
$t_{dmclk\sync}$	Delay time from PCM_CLK low to PCM_SYNC low (Long Frame Sync only)		-	-	20	ns
$t_{dmclk\hsync}$	Delay time from PCM_CLK high to PCM_SYNC low		-	-	20	ns
$t_{dmclk\lpoutz}$	Delay time from PCM_CLK low to PCM_OUT high impedance		-	-	20	ns
$t_{dmclk\hpoutz}$	Delay time from PCM_CLK high to PCM_OUT high impedance		-	-	20	ns
$t_{supinclk}$	Set-up time for PCM_IN valid to PCM_CLK low		20	-	-	ns
$t_{hpinclk}$	Hold time for PCM_CLK low to PCM_IN invalid		0	-	-	ns

Table 10.6: PCM Master Timing

(a) Assumes normal system clock operation. Figures vary during low-power modes, when system clock speeds are reduced.

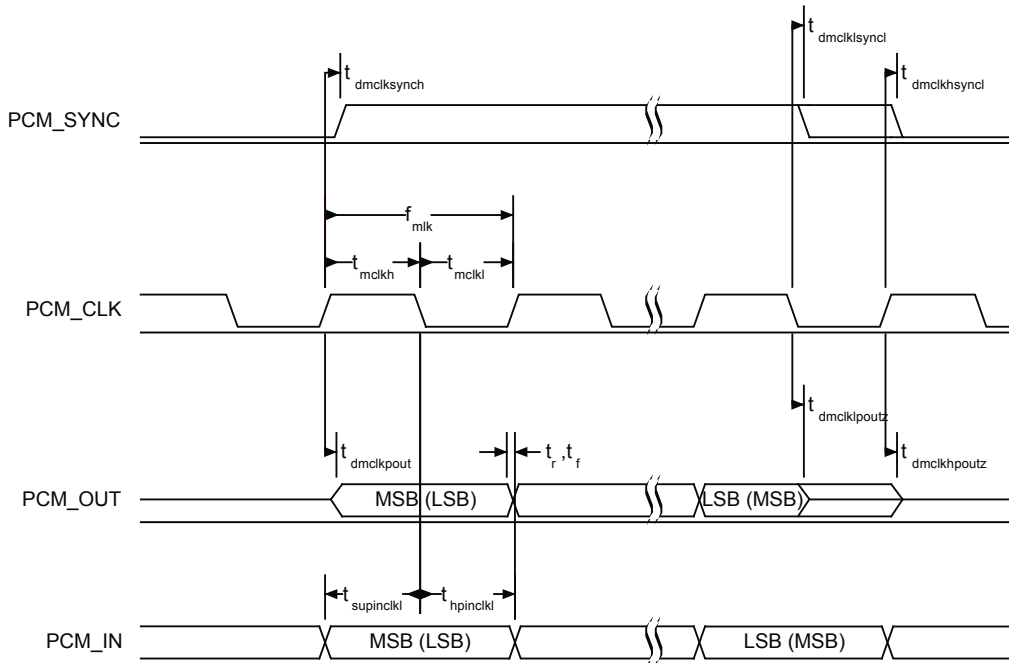
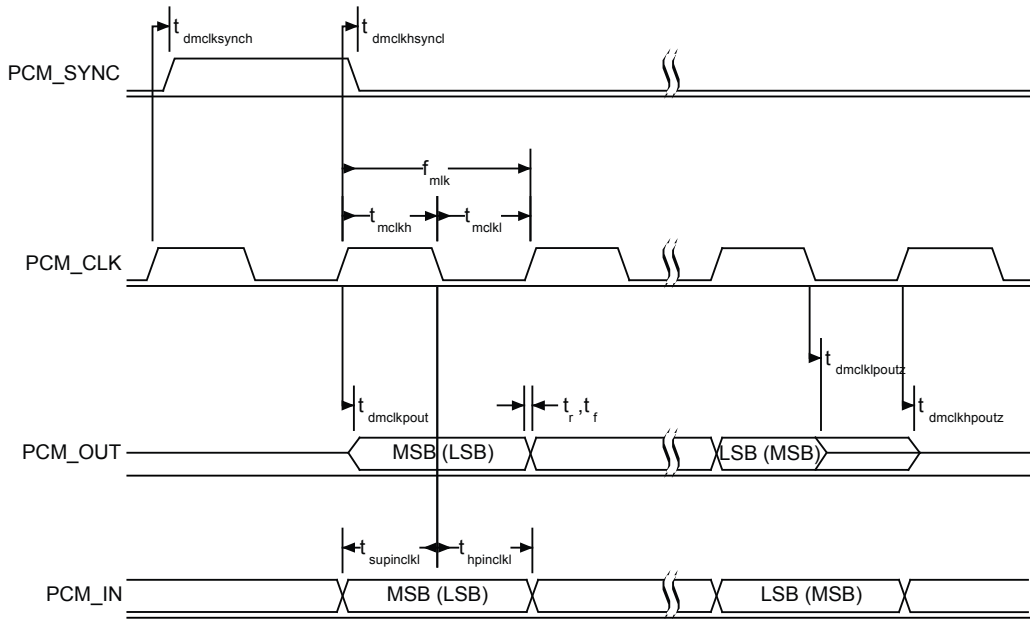

Figure 10.18: PCM Master Timing Long Frame Sync

G-TW-0000224.2.3



G-TW-0000225.3.3

Figure 10.19: PCM Master Timing Short Frame Sync

Symbol	Parameter	Min	Typ	Max	Unit
f_{sclk}	PCM clock frequency (Slave mode: input)	64	-	(a)	kHz
f_{sclk}	PCM clock frequency (GCI mode)	128	-	(b)	kHz
t_{sckl}	PCM_CLK low time	200	-	-	ns
t_{sckh}	PCM_CLK high time	200	-	-	ns
$t_{hscklsynch}$	Hold time from PCM_CLK low to PCM_SYNC high	2	-	-	ns
$t_{suscklsynch}$	Set-up time for PCM_SYNC high to PCM_CLK low	20	-	-	ns
t_{dpout}	Delay time from PCM_SYNC or PCM_CLK, whichever is later, to valid PCM_OUT data (Long Frame Sync only)	-	-	20	ns
$t_{dckhpout}$	Delay time from CLK high to PCM_OUT valid data	-	-	15	ns
t_{dpoutz}	Delay time from PCM_SYNC or PCM_CLK low, whichever is later, to PCM_OUT data line high impedance	-	-	15	ns
$t_{supinsckl}$	Set-up time for PCM_IN valid to CLK low	20	-	-	ns
$t_{hpinsckl}$	Hold time for PCM_CLK low to PCM_IN invalid	2	-	-	ns

Table 10.7: PCM Slave Timing

(a) Max frequency is the frequency defined by PSKEY_PCM_MIN_CPU_CLOCK

(b) Max frequency is twice the frequency defined by PSKEY_PCM_MIN_CPU_CLOCK

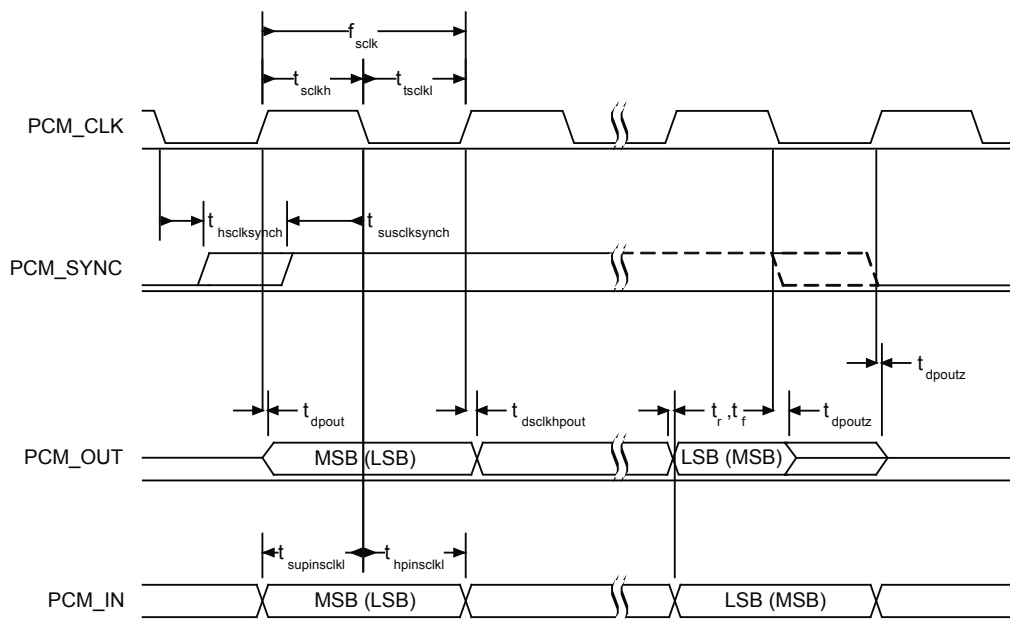

Figure 10.20: PCM Slave Timing Long Frame Sync

G-TW-0000226.3.2

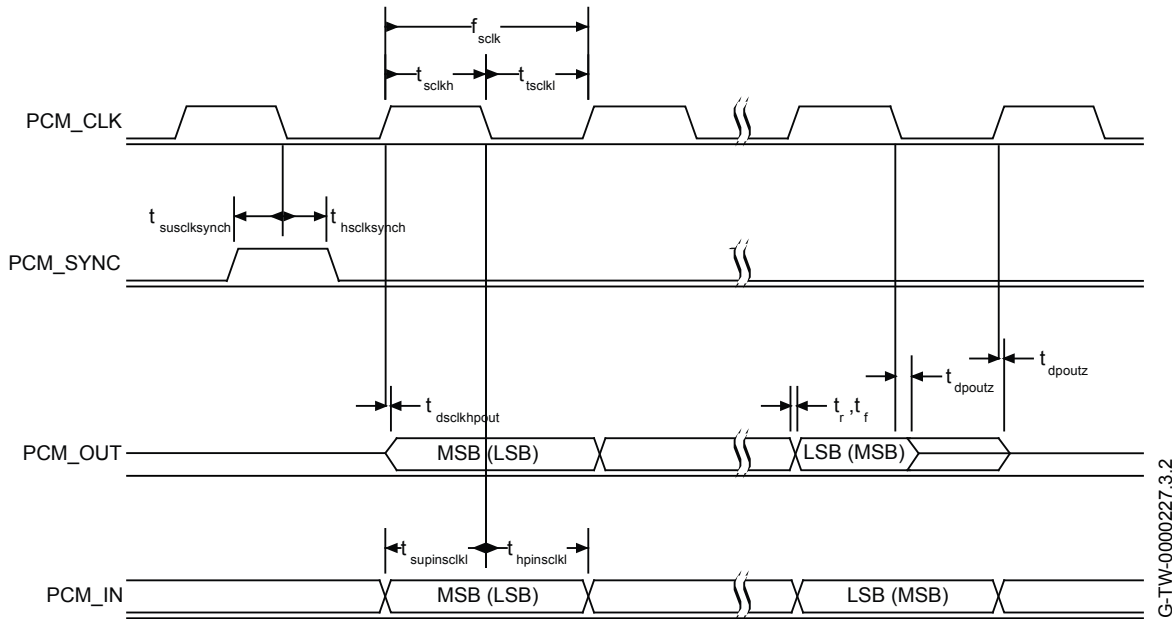

Figure 10.21: PCM Slave Timing Short Frame Sync

10.3.9 PCM_CLK and PCM_SYNC Generation

CSR8675 BGA has 2 methods of generating PCM_CLK and PCM_SYNC in master mode:

- Generating these signals by DDS from CSR8675 BGA internal 4MHz clock. Using this mode limits PCM_CLK to 128, 256 or 512kHz and PCM_SYNC to 8kHz.
- Generating these signals by DDS from an internal 48MHz clock, which enables a greater range of frequencies to be generated with low jitter but consumes more power. To select this second method set bit 48M_PCM_CLK_GEN_EN in PSKEY_PCM_CONFIG32. When in this mode and with long frame sync, the length of PCM_SYNC is either 8 or 16 cycles of PCM_CLK, determined by LONG_LENGTH_SYNC_EN in PSKEY_PCM_CONFIG32.

Equation 10.3 describes PCM_CLK frequency when generated from the internal 48MHz clock:

$$f = \frac{CNT_RATE}{CNT_LIMIT} \times 24MHz$$

Equation 10.3: PCM_CLK Frequency Generated Using the Internal 48MHz Clock

Set the frequency of PCM_SYNC relative to PCM_CLK using Equation 10.4:

$$f = \frac{PCM_CLK}{SYNC_LIMIT \times 8}$$

Equation 10.4: PCM_SYNC Frequency Relative to PCM_CLK

CNT_RATE, CNT_LIMIT and SYNC_LIMIT are set using PSKEY_PCM_LOW_JITTER_CONFIG. As an example, to generate PCM_CLK at 512kHz with PCM_SYNC at 8kHz, set PSKEY_PCM_LOW_JITTER_CONFIG to 0x08080177.

10.3.10 PCM Configuration

Configure the PCM by using PSKEY_PCM_CONFIG32 and PSKEY_PCM_USE_LOW_JITTER_MODE, see *BlueCore Audio API Specification* and the PS Key file. The default for PSKEY_PCM_CONFIG32 is 0x00800000, i.e. first slot following sync is active, 13-bit linear voice format, long frame sync and interface master generating 256kHz PCM_CLK from 4MHz internal clock with no tristate of PCM_OUT.

10.4 I²S1 and I²S2 Interface

Important Note:

The term I²S refers to I²S1 and I²S2 interfaces.

The I²S interface shares the same pins as PCM interface but the audio buses are mutually exclusive in their usage. Section 10.3 shows shared pins for the PCM/I²S interface.

The I²S interface supports left-justified or right-justified.

Figure 10.22 shows the timing diagram.

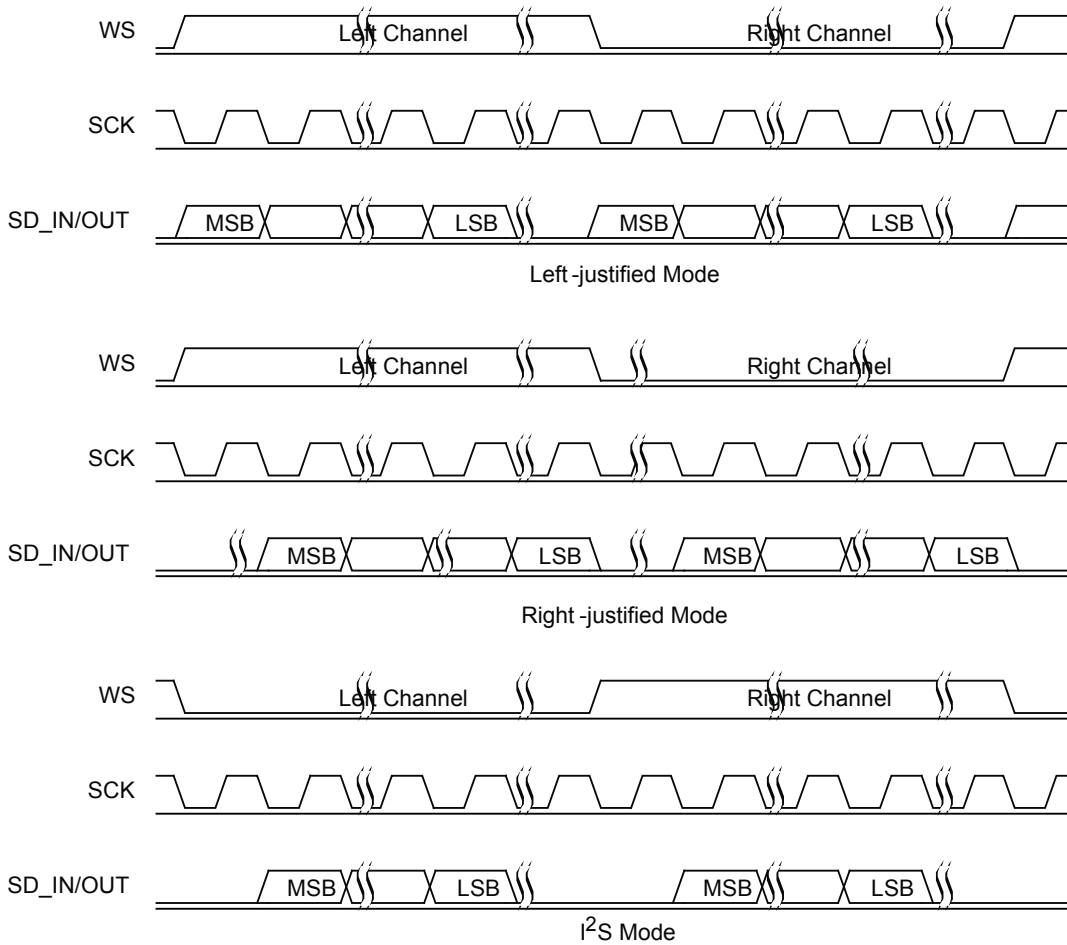

Figure 10.22: I²S Digital Audio Interface Modes

Configure the digital audio interface using PSKEY_DIGITAL_AUDIO_CONFIG, see *Firmware Configuration Keys for CSR8675* and the PS Key file.

Symbol	Parameter	Min	Typ	Max	Unit
-	SCK Frequency	-	-	6.2	MHz
-	WS Frequency	-	-	96	kHz
t_{ch}	SCK high time	80	-	-	ns
t_{cl}	SCK low time	80	-	-	ns

Table 10.8: Digital Audio Interface Slave Timing

Symbol	Parameter	Min	Typ	Max	Unit
t_{ssu}	WS valid to SCK high set-up time	20	-	-	ns
t_{sh}	SCK high to WS invalid hold time	2.5	-	-	ns
t_{opd}	SCK low to SD_OUT valid delay time	-	-	20	ns
t_{isu}	SD_IN valid to SCK high set-up time	20	-	-	ns
t_{ih}	SCK high to SD_IN invalid hold time	2.5	-	-	ns

Table 10.9: I²S Slave Mode Timing

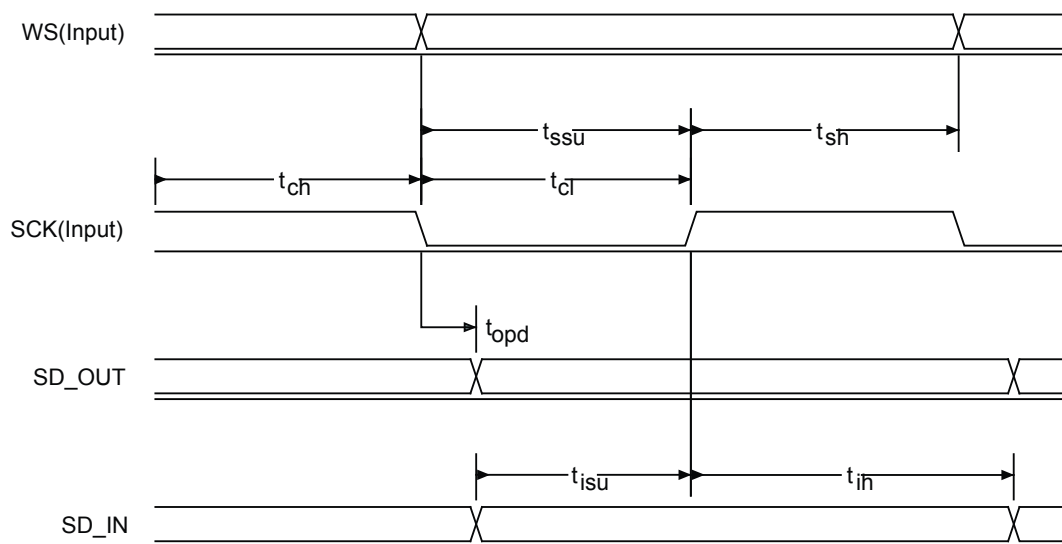

G-TW-0000231.2.2

Figure 10.23: Digital Audio Interface Slave Timing

Symbol	Parameter	Min	Typ	Max	Unit
-	SCK Frequency	-	-	6.2	MHz
-	WS Frequency	-	-	96	kHz

Table 10.10: Digital Audio Interface Master Timing

Symbol	Parameter	Min	Typ	Max	Unit
t_{spd}	SCK low to WS valid delay time	-	-	39.27	ns
t_{opd}	SCK low to SD_OUT valid delay time	-	-	18.44	ns
t_{isu}	SD_IN valid to SCK high set-up time	18.44	-	-	ns
t_{ih}	SCK high to SD_IN invalid hold time	0	-	-	ns

Table 10.11: I²S Master Mode Timing Parameters, WS and SCK as Outputs

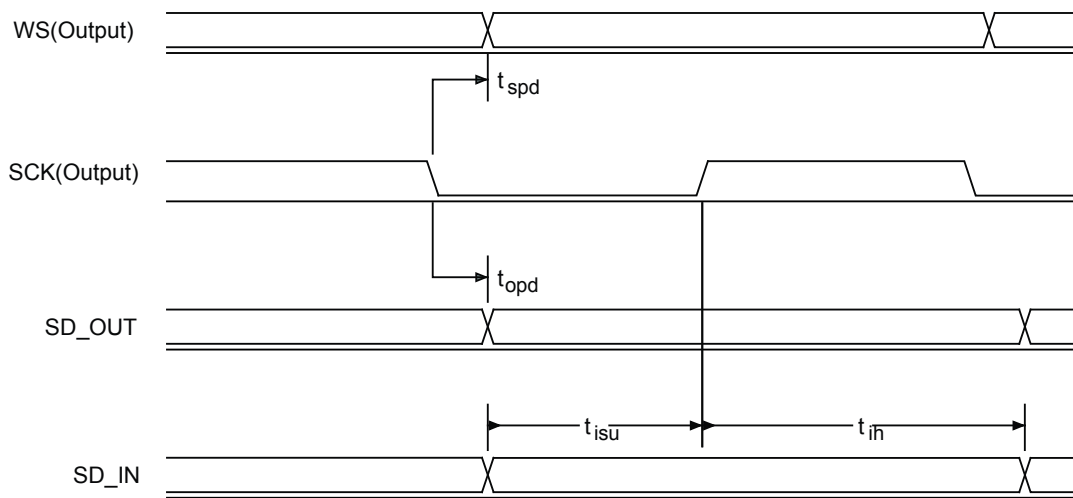

Figure 10.24: Digital Audio Interface Master Timing

11 WLAN Coexistence Interface

Dedicated hardware is provided to implement a variety of WLAN coexistence schemes. There is support for:

- Channel skipping AFH
- Priority signalling
- Channel signalling
- Host passing of channel instructions

Planned support for WLAN coexistence schemes includes:

- Unity-3
- Unity-3e
- Unity+

For more information on WLAN coexistence schemes see *BlueCore Bluetooth/IEEE 802.11 Coexistence Application Note*.

For more information on WLAN coexistence schemes supported on CSR8675 BGA see software release note or contact CSR.

12 Power Control and Regulation

For greater power efficiency the CSR8675 BGA contains 2 switch-mode regulators:

- 1 generates a 1.80V supply rail with an output current of 185mA, see Section 12.1.
- 1 generates a 1.35V supply rail with an output current of 160mA, see Section 12.2.
- Combining the 2 switch-mode regulators in parallel generates a single 1.80V supply rail with an output current of 340mA, see Section 12.3.

CSR8675 BGA contains 4 LDO linear regulators:

- 3.30V bypass regulator, see Section 12.4.
- 0.85 V to 1.20 V VDD_DIG linear regulator, see Section 12.5.
- 1.35V VDD_AUX linear regulator, see Section 12.6.
- 1.35V VDD_ANA linear regulator, see Section 12.7.

The recommended configurations for power control and regulation on the CSR8675 BGA are:

- 3 switch-mode configurations:
 - A 1.80V and 1.35V dual-supply rail system using the 1.80V and 1.35V switch-mode regulators, see Figure 12.1. This is the default power control and regulation configuration for the CSR8675 BGA.
 - A 1.80V single-supply rail system using the 1.80V switch-mode regulator.
 - A 1.80V parallel-supply rail system for higher currents using the 1.80V and 1.35V switch-mode regulators with combined outputs, see Figure 12.2.
- A linear configuration using an external 1.8V rail omitting all regulators

Table 12.1 shows settings for the recommended configurations for power control and regulation on the CSR8675 BGA.

Supply Configuration	Regulators				Supply Rail	
	Switch-mode		VDD_AUX Linear Regulator	VDD_ANA Linear Regulator	1.8V	1.35V
	1.8V	1.35V				
Dual-supply SMPS	ON	ON	OFF	OFF	SMPS	SMPS
Single-supply SMPS	ON	OFF	ON	ON	SMPS	LDO
Parallel-supply SMPS	ON	ON	ON	ON	SMPS	LDO
External 1.8V linear supply	OFF	OFF	ON	ON	External	LDO

Table 12.1: Recommended Configurations for Power Control and Regulation

For more information on CSR8675 BGA power supply configuration see *Configuring the Power Supplies on CSR867x* application note.

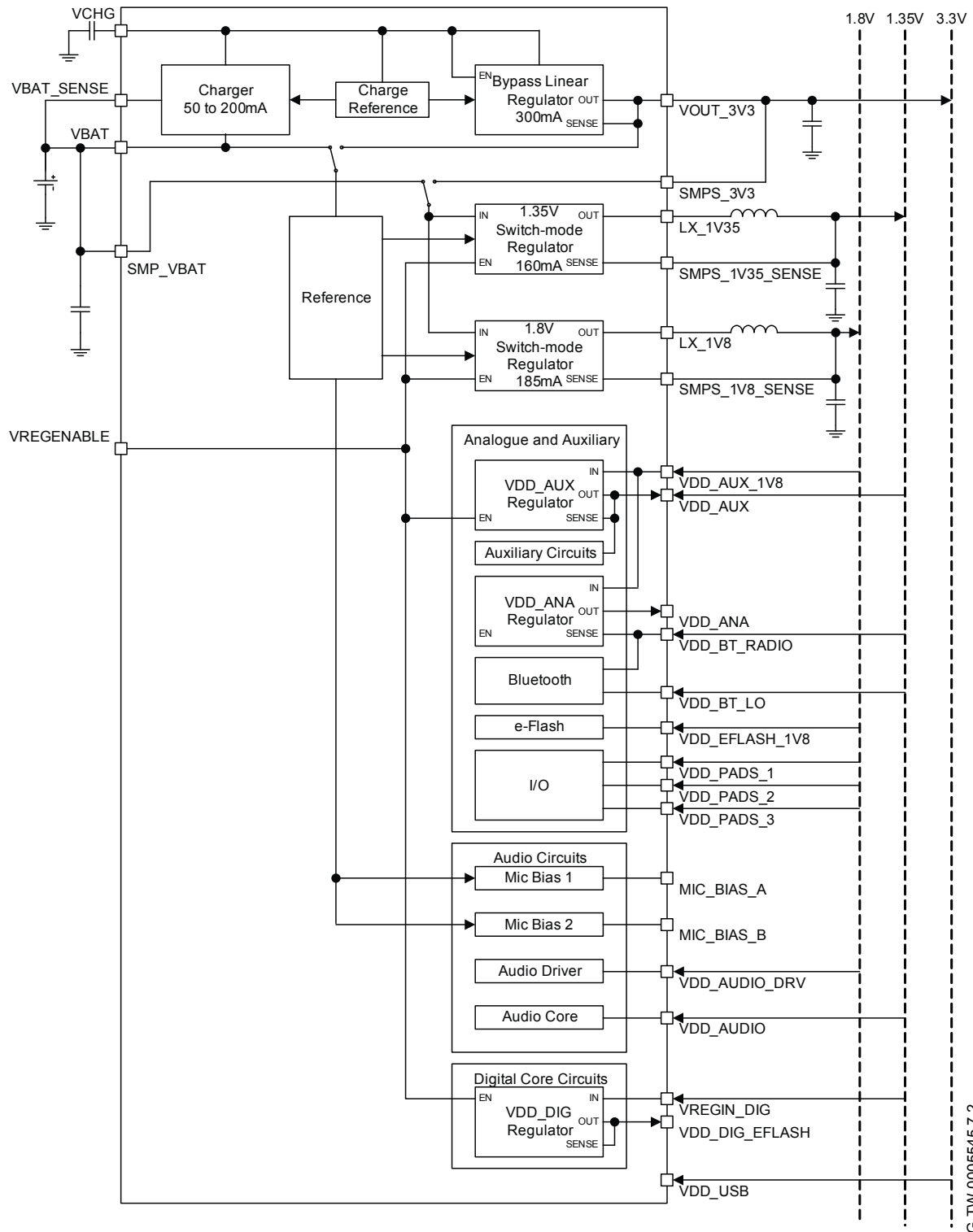

Figure 12.1: 1.80V and 1.35V Dual-supply Switch-mode System Configuration

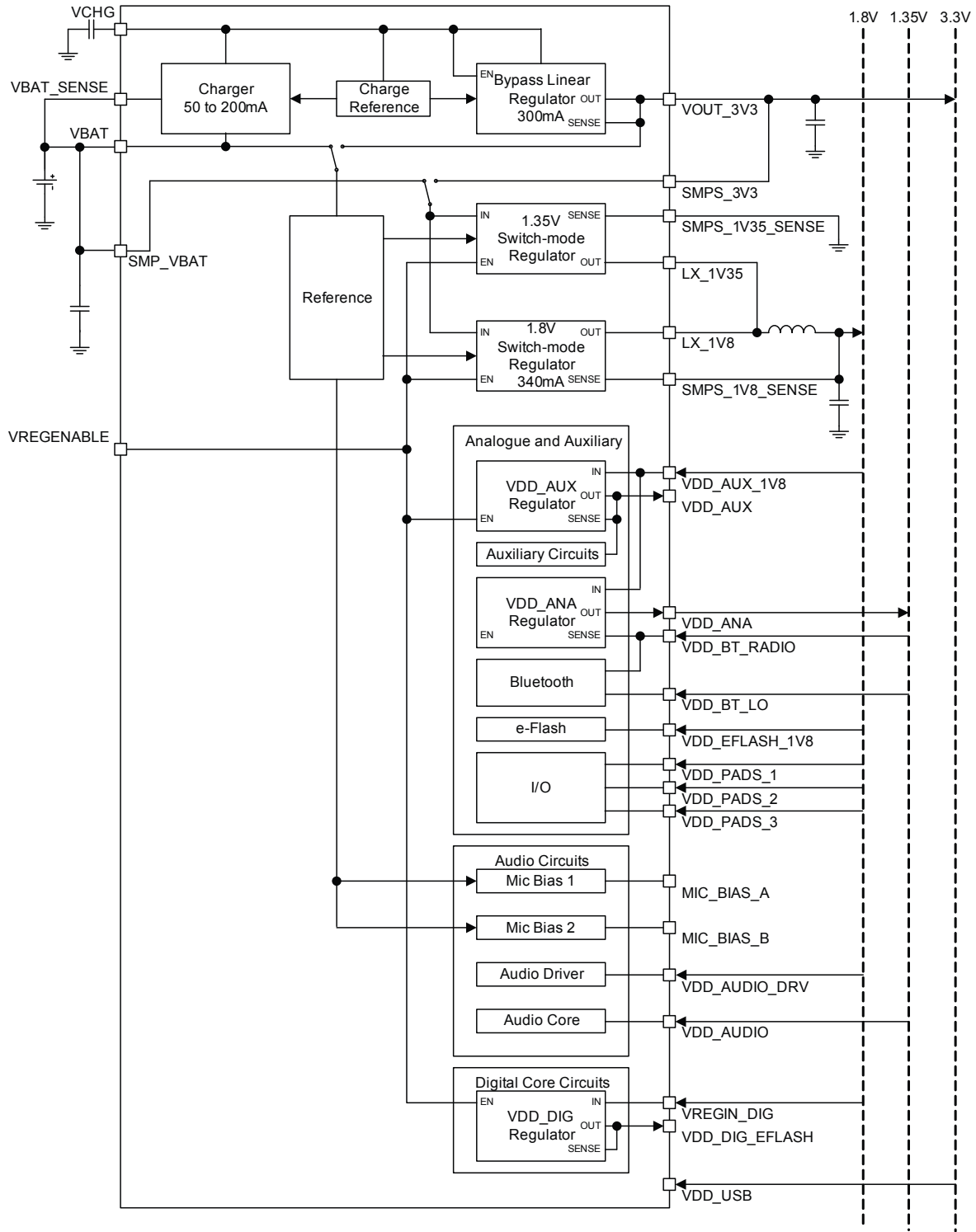
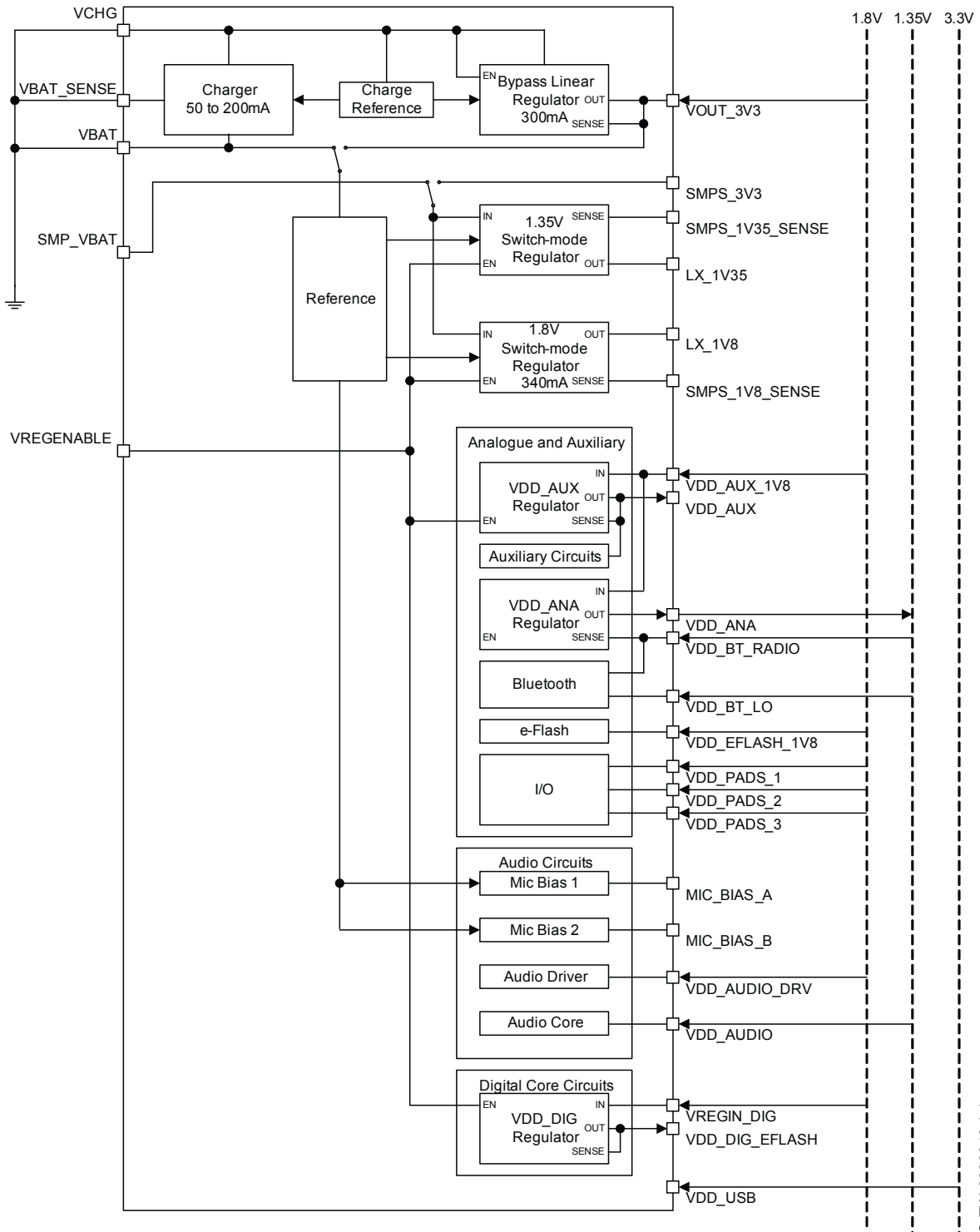

Figure 12.2: 1.80V Parallel-supply Switch-mode System Configuration



G-TW-0008349.1.1

Figure 12.3: External 1.8V System Configuration

12.1 1.8V Switch-mode Regulator

CSR recommends using the integrated switch-mode regulator to power the 1.80V supply rail.

Figure 12.4 shows that an external LC filter circuit of a low-resistance series inductor, L1 (4.7 μ H), followed by a low ESR shunt capacitor, C3 (2.2 μ F), is required between the LX_1V8 terminal and the 1.80V supply rail. Connect the 1.80V supply rail and the SMPS_1V8_SENSE pin.

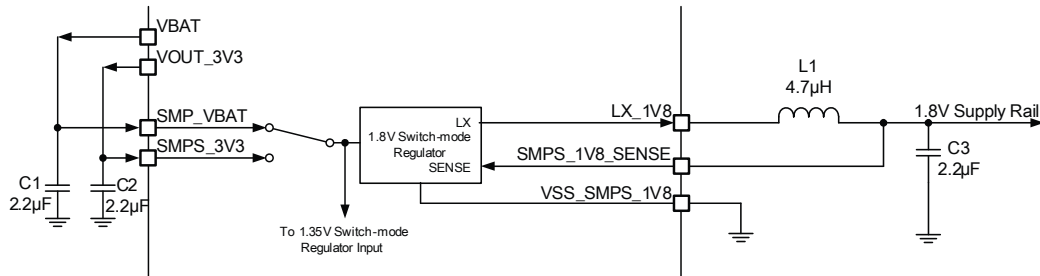

G-TW-0005542.3.2

Figure 12.4: 1.8V Switch-mode Regulator Output Configuration

Minimise the series resistance of the tracks between the regulator input, SMP_VBAT and SMPS_3V3, ground terminals, the filter and decoupling components, and the external voltage source to maintain high-efficiency power conversion and low supply ripple.

Ensure a solid ground plane between C1, C2, C3 and VSS_SMPS_1V8.

Also minimise the collective parasitic capacitance on the track between LX_1V8 and the inductor L1, to maximise efficiency.

For the regulator to meet the specifications in Section 16.3.1.1 requires a total resistance of <1.0 Ω (<0.5 Ω recommended) for the following:

- The track between the battery and SMP_VBAT.
- The track between LX_1V8 and the inductor.
- The inductor, L1, ESR.
- The track between the inductor, L1, and the sense point on the 1.80V supply rail.

The following enable the 1.80V switch-mode regulator:

- VREGENABLE pin
- The CSR8675 BGA firmware with reference to PSKEY_PSU_ENABLES
- VCHG pin

The switching frequency is adjustable by setting an offset from 4.00MHz using PSKEY_SMPS_FREQ_OFFSET, which also affects the 1.35V switch-mode regulator.

When the 1.80V switch-mode regulator is not required, leave unconnected:

- The regulator input SMP_VBAT and SMPS_3V3
- The regulator output LX_1V8

12.2 1.35V Switch-mode Regulator

CSR recommends using the integrated switch-mode regulator to power the 1.35V supply rail.

Figure 12.5 shows that an external LC filter circuit of a low-resistance series inductor L1 (4.7 μ H), followed by a low ESR shunt capacitor, C3 (4.7 μ F), is required between the LX_1V35 terminal and the 1.35V supply rail. Connect the 1.35V supply rail and the SMPS_1V35_SENSE pin.

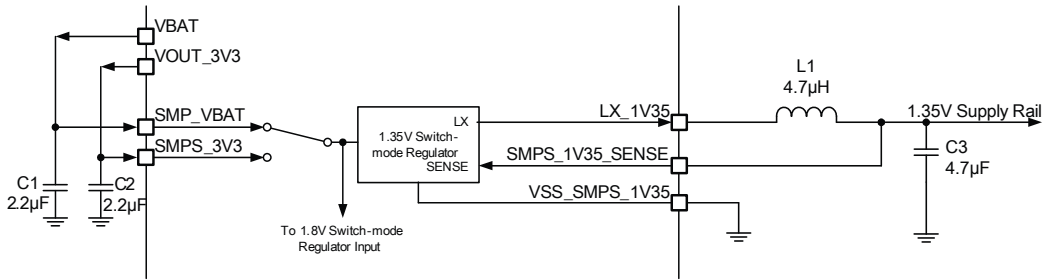

G-TW-0005543.4.2

Figure 12.5: 1.35V Switch-mode Regulator Output Configuration

Minimise the series resistance of the tracks between the regulator input, SMP_VBAT and SMPS_3V3, ground terminals, the filter and decoupling components, and the external voltage source to maintain high-efficiency power conversion and low supply ripple.

Ensure a solid ground plane between C1, C2, C3 and VSS_SMPS_1V35.

Also minimise the collective parasitic capacitance on the track between LX_1V35 and the inductor L1, to maximise efficiency.

For the regulator to meet the specifications in Section 16.3.2.1 requires a total resistance of $<1.0\Omega$ ($<0.5\Omega$ recommended) for the following:

- The track between the battery and SMP_VBAT.
- The track between LX_1V35 and the inductor.
- The inductor, L1, ESR.
- The track between the inductor, L1, and the sense point on the 1.35V supply rail.

The following enable the 1.35V switch-mode regulator:

- VREGENABLE pin
- The CSR8675 BGA firmware with reference to PSKEY_PSU_ENABLES
- VCHG pin

The switching frequency is adjustable by setting an offset from 4.00MHz using PSKEY_SMPS_FREQ_OFFSET, which also affects the 1.80V switch-mode regulator.

When the 1.35V switch-mode regulator is not required, leave unconnected:

- The regulator input SMP_VBAT and SMPS_3V3
- The regulator output LX_1V35

12.3 1.8V and 1.35V Switch-mode Regulators Combined

For applications that require a single 1.80V supply rail with higher currents CSR recommends combining the outputs of the integrated 1.80V and 1.35V switch-mode regulators in parallel to power a single 1.80V supply rail, see Figure 12.6.

Figure 12.6 shows that an external LC filter circuit of a low-resistance series inductor L1 (4.7µH), followed by a low ESR shunt capacitor, C3 (2.2µF), is required between the LX_1V35 terminal and the 1.80V supply rail. Connect the 1.80V supply rail and the SMPS_1V35_SENSE pin and ground the SMPS_1V35_SENSE pin.

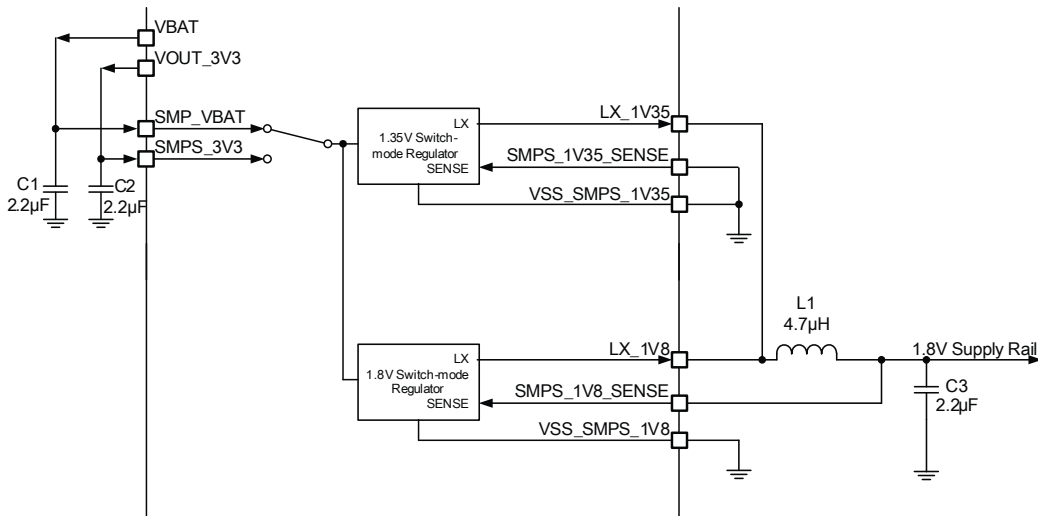

G-TW-0005544.3.2

Figure 12.6: 1.8V and 1.35V Switch-mode Regulators Outputs Parallel Configuration

Minimise the series resistance of the tracks between the regulator input SMP_VBAT and SMPS_3V3, ground terminals, the filter and decoupling components, and the external voltage source to maintain high-efficiency power conversion and low supply ripple.

Ensure a solid ground plane between C1, C2, C3, VSS_SMPS_1V8 and VSS_SMPS_1V35.

Also minimise the collective parasitic capacitance on the track between LX_1V8, LX_1V35 and the inductor L1, to maximise efficiency.

For the regulator to meet the specifications in Section 16.3.1.2 requires a total resistance of <math><1.0\Omega</math> (<math><0.5\Omega</math> recommended) for the following:

- The track between the battery and SMP_VBAT.
- The track between LX_1V8, LX_1V35 and the inductor.
- The inductor L1, ESR.
- The track between the inductor, L1, and the sense point on the 1.80V supply rail.

The following enable the 1.80V switch-mode regulator:

- VREGENABLE pin
- The CSR8675 BGA firmware with reference to PSKEY_PSU_ENABLES
- VCHG pin

The switching frequency is adjustable by setting an offset from 4.00MHz using PSKEY_SMPS_FREQ_OFFSET.

When the 1.80V switch-mode regulator is not required, leave unconnected:

- The regulator input SMP_VBAT and SMPS_3V3
- The regulator output LX_1V8

12.4 Bypass LDO Linear Regulator

The integrated bypass LDO linear regulator is available as a 3.30V supply rail and is an alternative supply rail to the battery supply. This is especially useful when the battery has no charge and the CSR8675 BGA needs to power up. The input voltage should be between 4.25V and 6.50V. The maximum current from this regulator is 250mA.

Note:

The integrated bypass LDO linear regulator can operate down to 3.1V with a reduced performance.

Externally decouple the output of this regulator using a low ESR MLC capacitor of a minimum 2.2µF to the VOUT_3V3 pin. With careful PCB layout this bypass capacitor can be shared with SMPS_3V3.

The output voltage is switched on when VCHG gets above 3.0V.

12.5 Low-voltage VDD_DIG Linear Regulator

The integrated low-voltage VDD_DIG linear regulator is available to power a 0.85 V to 1.20 V supply rail which includes the digital circuits on CSR8675 BGA. The input voltage range is between 1.30V and 1.95V. The maximum current from this regulator is 80mA.

Externally decouple the output of this regulator using a low ESR MLC capacitor of 470nF to VDD_DIG_EEFLASH1 and VDD_DIG_EEFLASH2 pins for optimum phase margin. CSR recommends due to increased current draw that K2 (VDD_DIG_EEFLASH2) is connected to E12 (VDD_DIG_EEFLASH1) on CSR8675 BGA designs. This is back compatible with CSR8670 BGA

The output voltage is enabled by VREGENABLE and the low-voltage VDD_DIG linear regulator must be on to run software code.

12.6 Low-voltage VDD_AUX Linear Regulator

The integrated low-voltage VDD_AUX linear regulator is available to power a 1.35V auxiliary supply rail (when the 1.35V switch-mode regulator is not used) which includes the analogue circuits on CSR8675 BGA. The input voltage should be between 1.70V and 1.95V. The maximum current from this regulator is 5mA.

Externally decouple the output of this regulator using a low ESR MLC capacitor of a minimum 470nF to the VDD_AUX pin.

Connect a 2.2µF capacitor between the input to the regulator and ground to ensure stability.

This regulator is enabled by taking VREGENABLE or VCHG high and also the software controls the regulator enable/disable through PSKEY_PSU_ENABLES.

For safety, the initial output voltage of the low-voltage VDD_AUX linear regulator is 1.25V.

12.7 Low-voltage VDD_ANA Linear Regulator

The integrated low-voltage VDD_ANA linear regulator is available to power an optional 1.35V analogue supply rail which includes the analogue circuits on CSR8675 BGA. The input voltage should be between 1.70V and 1.95V. The maximum current from this regulator is 60mA.

If this regulator is required:

- Externally decouple the output of this regulator using a 2.2µF low ESR MLC capacitor to the VDD_ANA pin
- Connect a 2.2µF capacitor between the input to the regulator and ground to ensure stability

The software controls the regulator enable/disable through PSKEY_PSU_ENABLES.

12.8 Voltage Regulator Enable

When using the integrated regulators the voltage regulator enable pin, VREGENABLE, enables the CSR8675 BGA and the following regulators:

- 1.8V switch-mode regulator
- 1.35V switch-mode regulator
- Low-voltage VDD_DIG linear regulator
- Low-voltage VDD_AUX linear regulator

The VREGENABLE pin is active high, with a weak pull-down.

CSR8675 BGA boots-up when the voltage regulator enable pin is pulled high, enabling the regulators. The firmware then latches the regulators on. The voltage regulator enable pin can then be released.

The status of the VREGENABLE pin is available to firmware through an internal connection. VREGENABLE also works as an input line.

Note:

VREGENABLE should be asserted after the VBAT supply when VREGENABLE is not used as a power-on button.

12.9 External Regulators and Power Sequencing

CSR recommends that the integrated regulators supply the CSR8675 BGA and it is configured based on the information in this data sheet.

If any of the supply rails for the CSR8675 BGA are supplied from an external regulator, then it should match or be better than the internal regulator available on CSR8675 BGA. For more information see regulator characteristics in Section 16.

Note:

The internal regulators described in Section 12.1 to Section 12.7 are not recommended for external circuitry other than that shown in Section 14.

For information about power sequencing of external regulators to supply the CSR8675 BGA contact CSR.

12.10 Reset, RST#

CSR8675 BGA is reset from several sources:

- RST# pin
- Power-on reset
- USB charger attach reset
- UART break character
- Software configured watchdog timer

The RST# pin is an active low reset and is internally filtered using the internal low frequency clock oscillator. CSR recommends applying RST# for a period >5ms.

The power-on reset occurs when:

- The VDD_DIG supply falls below typically 0.97V
- or
- The VDD_AUX_1V8 supply falls below typically 1.46V

And is released when:

- VDD_DIG rises above typically 1.10V
- or
- VDD_AUX_1V8 rises above typically 1.65V

At reset the digital I/O pins are set to inputs for bidirectional pins and outputs are set to tristate. Following a reset, CSR8675 BGA assumes the maximum XTAL_IN frequency, which ensures that the internal clocks run at a safe (low) frequency until CSR8675 BGA is configured for the actual XTAL_IN frequency. If no clock is present at XTAL_IN, the oscillator in CSR8675 BGA free runs, again at a safe frequency.

12.10.1 Digital Pin States on Reset

Table 12.2 shows the pin states of CSR8675 BGA on reset. PU and PD default to weak values unless specified otherwise.

Pin Name / Group	I/O Type	Full Chip Reset
USB_DP	Digital bidirectional	N/A
USB_DN	Digital bidirectional	N/A
UART_RX	Digital bidirectional with PU	Strong PU
UART_TX	Digital bidirectional with PU	Weak PU
UART_CTS	Digital bidirectional with PD	Weak PD
UART_RTS	Digital bidirectional with PU	Weak PU
SPI_CS#	Digital input with PU	Strong PU
SPI_CLK	Digital input with PD	Weak PD

Pin Name / Group	I/O Type	Full Chip Reset
SPI_MISO	Digital tristate output with PD	Weak PD
SPI_MOSI	Digital input with PD	Weak PD
PCM_IN	Digital bidirectional with PD	Weak PD
PCM_OUT	Digital bidirectional with PD	Weak PD
PCM_SYNC	Digital bidirectional with PD	Weak PD
PCM_CLK	Digital bidirectional with PD	Weak PD
RST#	Digital input with PU	Strong PU
PIO[15:0]	Digital bidirectional with PD	Weak PD
QSPI_FLASH_IO[3:0]	Digital bidirectional with PD	Strong PD
QSPI_SRAM_CS#	Digital bidirectional with PU	Strong PU
QSPI_FLASH_CS#	Digital bidirectional with PU	Strong PU
QSPI_SRAM_CLK	Digital bidirectional with PD	Strong PD
QSPI_FLASH_CLK	Digital bidirectional with PD	Strong PD

Table 12.2: Pin States on Reset

12.10.2 Status After Reset

The status of CSR8675 BGA after a reset is:

- Warm reset: baud rate and RAM data remain available
- Cold reset: baud rate and RAM data not available

12.11 Automatic Reset Protection

CSR8675 BGA includes an automatic reset protection circuit which restarts/resets CSR8675 BGA when an unexpected reset occurs, e.g. ESD strike or lowering of RST#. The automatic reset protection circuit enables resets from the VM without the requirement for external circuitry.

Note:

The reset protection is cleared after typically 2s (1.6s min to 2.4s max).

If RST# is held low for >2.4s CSR8675 BGA turns off. A rising edge on VREGENABLE or VCHG is required to power on CSR8675 BGA.

13 Battery Charger

13.1 Battery Charger Hardware Operating Modes

The battery charger hardware is controlled by the VM, see Section 13.3. The battery charger has 5 modes:

- Disabled
- Trickle charge
- Fast charge
- Standby: fully charged or float charge
- Error: charging input voltage, VCHG, is too low

The battery charger operating mode is determined by the battery voltage and current, see Table 13.1 and Figure 13.1.

The internal charger circuit can provide up to 200mA of charge current, for currents higher than this the CSR8675 BGA can control an external pass transistor, see Section 13.5.

Mode	Battery Charger Enabled	VBAT_SENSE
Disabled	No	X
Trickle charge	Yes	>0 and $<V_{fast}$
Fast charge	Yes	$>V_{fast}$ and $<V_{float}$
Standby	Yes	$I_{term}^{(a)}$ and $>(V_{float} - V_{hyst})$
Error	Yes	$>(VCHG - 50mV)$

Table 13.1: Battery Charger Operating Modes Determined by Battery Voltage and Current

^(a) I_{term} is approximately 10% of I_{fast} for a given I_{fast} setting

Figure 13.1 shows the mode-to-mode transition voltages. These voltages are fixed and calibrated by CSR, see Section 13.2. The transition between modes can occur at any time.

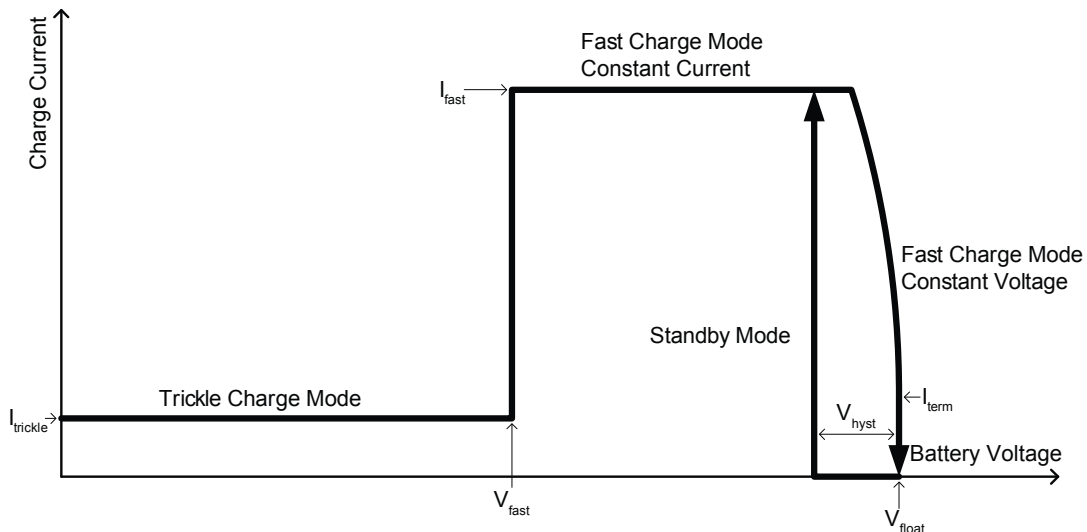

Figure 13.1: Battery Charger Mode-to-Mode Transition Diagram

Note:

The battery voltage remains constant in Fast Charge Constant Voltage Mode, the curved line on Figure 13.1 is for clarity only.

13.1.1 Disabled Mode

In the disabled mode the battery charger is fully disabled and draws no active current on any of its terminals.

13.1.2 Trickle Charge Mode

In the trickle charge mode, when the voltage on VBAT_SENSE is lower than the V_{fast} threshold, a current of approximately 10% of the fast charge current, I_{fast} , is sourced from the VBAT pin.

The V_{fast} threshold detection has hysteresis to prevent the charger from oscillating between modes.

13.1.3 Fast Charge Mode

When the voltage on VBAT_SENSE is greater than V_{fast} , the current sourced from the VBAT pin increases to I_{fast} . I_{fast} is between 10mA and 200mA set by PS Key or a VM trap. In addition, I_{fast} is calibrated in production test to correct for process variation in the charger circuit.

The current is held constant at I_{fast} until the voltage at VBAT_SENSE reaches V_{float} , then the charger reduces the current sourced to maintain a constant voltage on the VBAT_SENSE pin.

When the current sourced is below the termination current, I_{term} , the charging stops and the charger enters standby mode. I_{term} is typically 10% of the fast charge current.

13.1.4 Standby Mode

When the battery is fully charged, the charger enters standby mode, and battery charging stops. The battery voltage on the VBAT_SENSE pin is monitored, and when it drops below a threshold set at V_{hyst} below the final charging voltage, V_{float} , the charger re-enters fast charge mode.

13.1.5 Error Mode

The charger enters the error mode if the voltage on the VCHG pin is too low to operate the charger correctly (VBAT_SENSE is greater than VCHG - 50mV (typical)).

In this mode, charging is stopped. The battery charger does not require a reset to resume normal operation.

13.2 Battery Charger Trimming and Calibration

The battery charger default trim values are written by CSR into non-volatile memory when each IC is characterised. CSR provides various PS Keys for overriding the default trims, see Section 13.4.

13.3 VM Battery Charger Control

The VM charger code has overall supervisory control of the battery charger and is responsible for:

- Responding to charger power connection/disconnection events
- Monitoring the temperature of the battery
- Monitoring the temperature of the die to protect against silicon damage
- Monitoring the time spent in the various charge states
- Enabling/disabling the charger circuitry based on the monitored information
- Driving the user visible charger status LED(s)

13.4 Battery Charger Firmware and PS Keys

The battery charger firmware sets up the charger hardware based on the PS Key settings and traps called from the VM charger code. It also performs the initial analogue trimming. Settings for the charger current depend on the battery capacity and type, which are set by the user in the PS Keys.

For more information on the CSR8675 BGA, including details on setting up, calibrating, trimming and the PS Keys, see *Lithium Polymer Battery Charger Calibration and Operation for CSR867x* application note.

13.5 External Mode

The external mode is for charging higher capacity batteries using an external pass device. The current is controlled by sinking a varying current into the CHG_EXT pin, and the current is determined by measuring the voltage drop across a resistor, R_{sense} , connected in series with the external pass device, see Figure 13.2. The voltage drop is determined by looking at the difference between the VBAT_SENSE and VBAT pins. The voltage drop across R_{sense} is typically 200mV. The value of the external series resistor determines the charger current. This current can be trimmed with a PS Key.

In Figure 13.2, R1 (220mΩ) and C1 (4.7μF) form an RC snubber that is required to maintain stability across all battery ESRs. The battery ESR must be <1.0Ω.

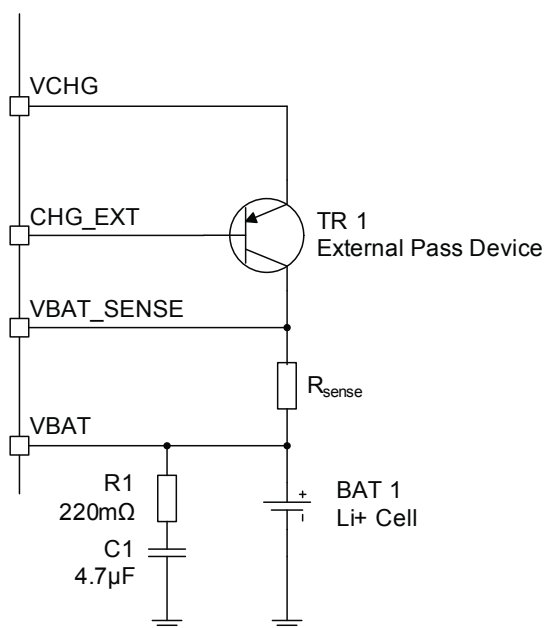

Figure 13.2: Battery Charger External Mode Typical Configuration

For optimum stability select TR1 to have Hfe current gain within the specification in Section 16.3.4 while ensuring that the CHG_EXT current remains below the limit stated in Section 16.3.4 at the desired charge current.

Ensure heat dissipation within TR1 and R_{sense} are considered within the design. Selectable external charge rates are possible with additional PIO controlled switches to change overall R_{sense} .

G-TW-0005585.2.3

14 Example Application Schematic

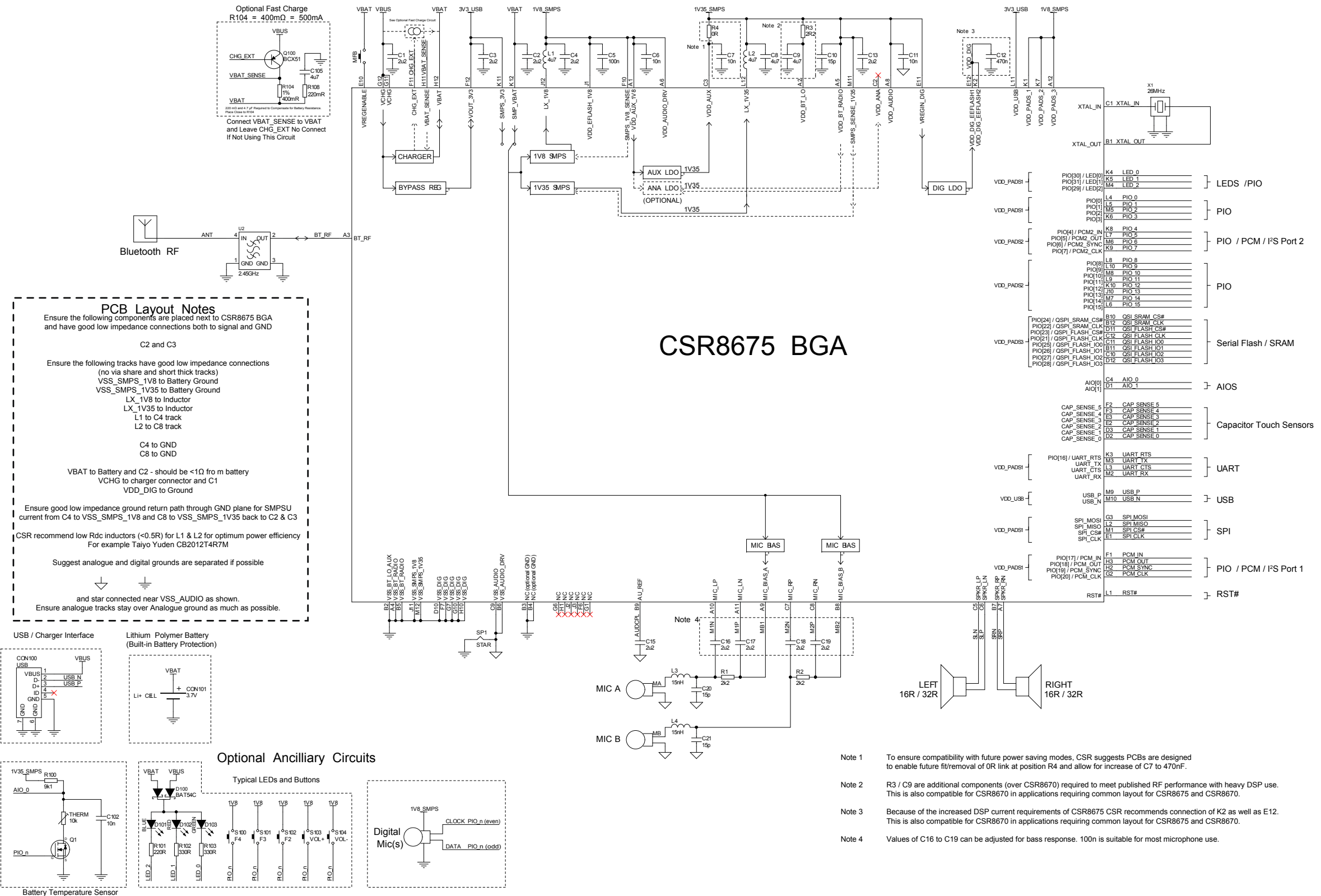

- Note 1 To ensure compatibility with future power saving modes, CSR suggests PCBs are designed to enable future fit/removal of 0R link at position R4 and allow for increase of C7 to 470nF.
- Note 2 R3 / C9 are additional components (over CSR8670) required to meet published RF performance with heavy DSP use. This is also compatible for CSR8670 in applications requiring common layout for CSR8675 and CSR8670.
- Note 3 Because of the increased DSP current requirements of CSR8675 CSR recommends connection of K2 as well as E12. This is also compatible for CSR8670 in applications requiring common layout for CSR8675 and CSR8670.
- Note 4 Values of C16 to C19 can be adjusted for bass response. 100n is suitable for most microphone use.

G-TW-0012759.2.2

15 Example Application Using Different Power Supply Configurations

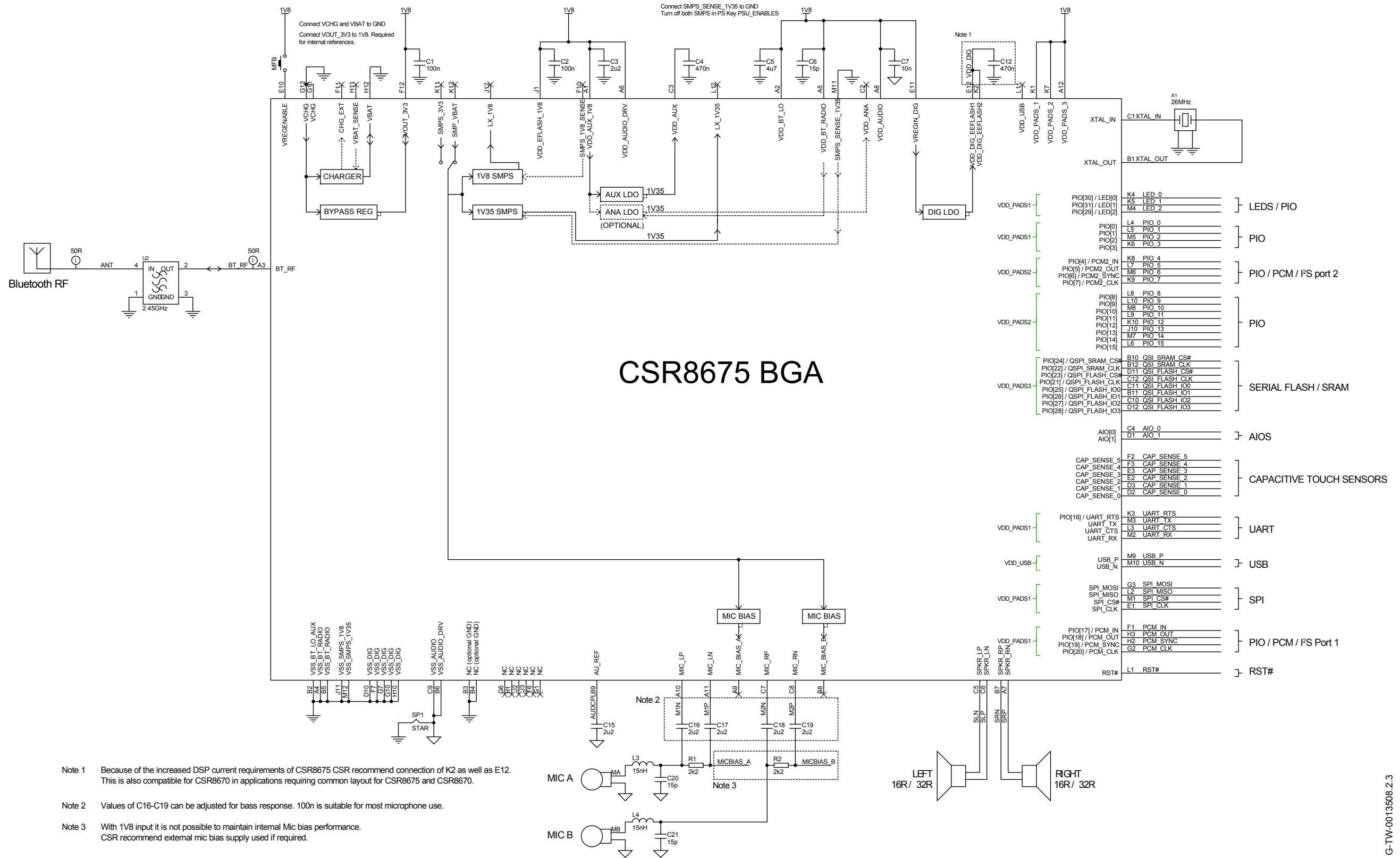

Figure 15.1: External 1.8V Supply Example Application

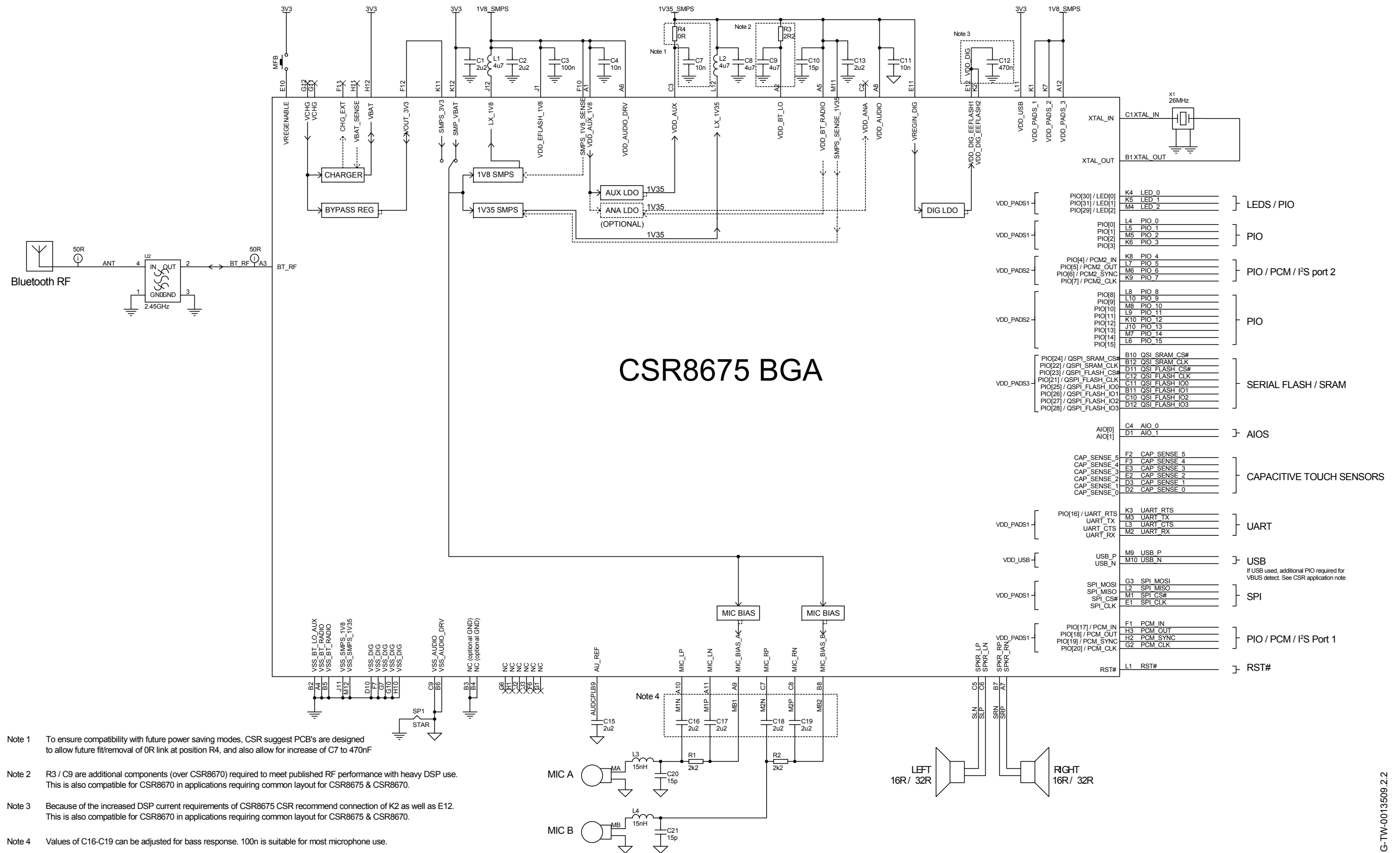

Figure 15.2: External 3.3V Supply Example Application

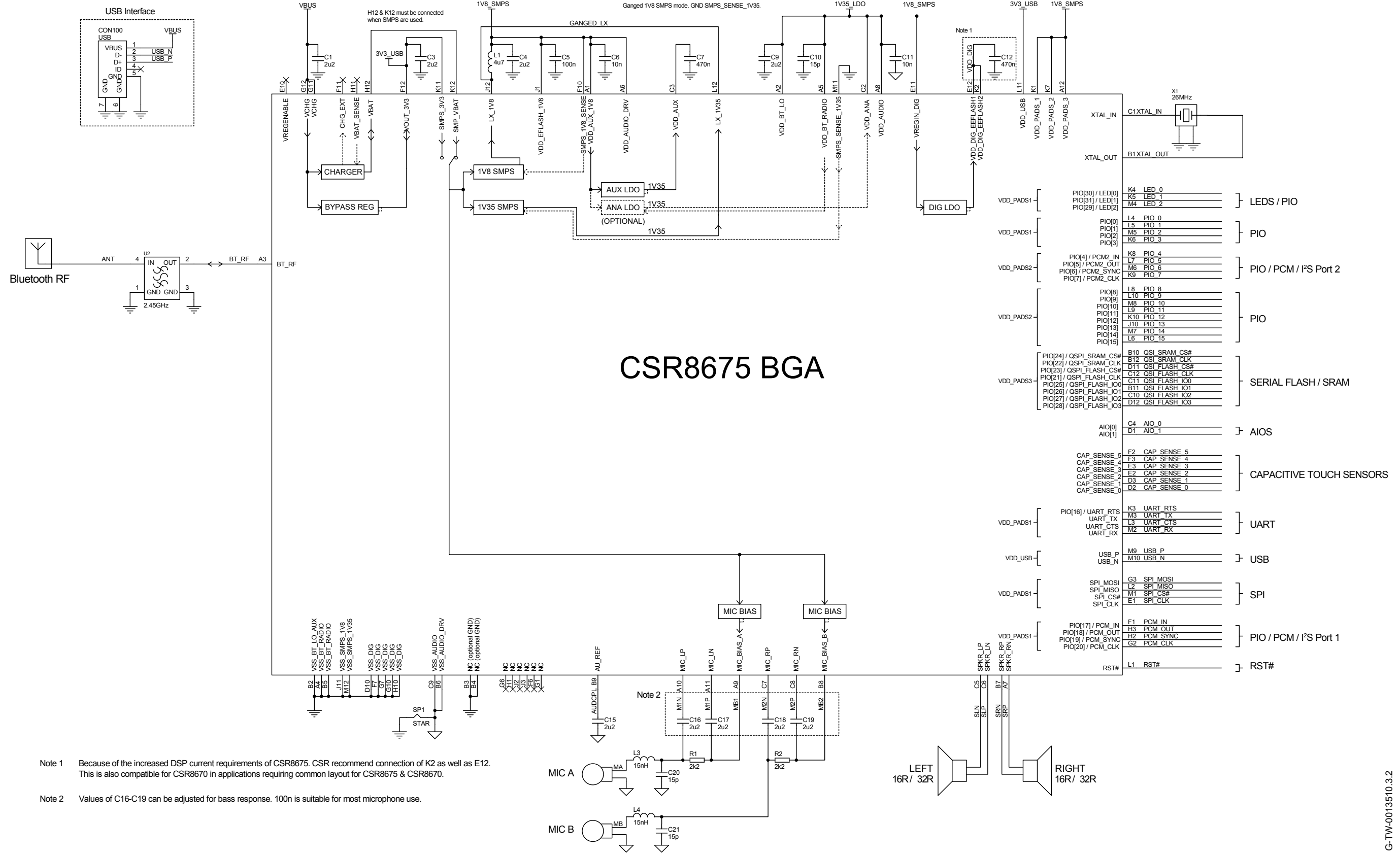

Figure 15.3: USB Dongle Example Application

16 Electrical Characteristics

16.1 Absolute Maximum Ratings

Absolute Maximum Ratings		Min	Max	Unit
Storage temperature		-40	105	°C
Supply Voltage				
5 V (USB VBUS)	VCHG	-0.4	5.75 / 6.50 ^(a)	V
3.3 V	SMPS_3V3	-0.4	3.60	V
	VDD_USB	-0.4	3.60	V
Battery	LED[2:0]	-0.4	4.40	V
	SMP_VBAT	-0.4	4.40	V
	VBAT_SENSE	-0.4	5.75	V
	VREGENABLE	-0.4	4.40	V
PIO	VDD_PADS_1	-0.4	3.60	V
	VDD_PADS_2	-0.4	3.60	V
	VDD_PADS_3	-0.4	3.60	V
1.8 V	VDD_AUDIO_DRV	-0.4	1.95	V
	VDD_AUX_1V8	-0.4	1.95	V
	SMPS_1V8_SENSE	-0.4	1.95	V
1.35 V	SMPS_1V35_SENSE	-0.4	1.45	V
	VDD_AUDIO	-0.4	1.45	V
	VREGIN_DIG	-0.4	1.95	V
Other terminal voltages		VSS - 0.4	VDD + 0.4	V

^(a) Standard maximum input voltage is 5.75 V, a 6.50 V maximum depends on firmware version and implementation of over-temperature protection software, for more information contact CSR.

16.2 Recommended Operating Conditions

Recommended Operating Conditions		Min	Typ	Max	Unit
Operating temperature range		-40	20	85	°C
Supply Voltage					
5 V (USB VBUS)	VCHG	4.75 / 3.10 ^(a)	5.00	5.75 / 6.50 ^(b)	V
3.3 V	SMPS_3V3	3.10	3.30	3.60	V
	VDD_USB	3.10	3.30	3.60	V
Battery	LED[2:0]	1.10	3.70	4.30	V
	SMP_VBAT	2.80	3.70	4.30	V
	VBAT_SENSE	0	3.70	4.30	V
	VREGENABLE	0	3.70	4.25	V
PIO	VDD_PADS_1	1.70	1.80	3.60	V
	VDD_PADS_2	1.70	1.80	3.60	V
	VDD_PADS_3	1.70	1.80	3.60	V
1.8 V	VDD_AUDIO_DRV	1.70	1.80	1.95	V
	VDD_AUX_1V8	1.70	1.80	1.95	V
	SMPS_1V8_SENSE	1.70	1.80	1.95	V
1.35 V	SMPS_1V35_SENSE	1.30	1.35	1.40	V
	VDD_AUDIO	1.30	1.35	1.40	V
	VREGIN_DIG	1.30	1.35 or 1.80 ^(c)	1.95	V

^(a) Minimum input voltage of 4.75 V is required for full specification, regulator operates at reduced load current from 3.1 V.

^(b) Standard maximum input voltage is 5.75 V, a 6.50 V maximum depends on firmware version and implementation of over-temperature protection software, for more information contact CSR.

^(c) Typical value depends on output required by the low-voltage VDD_DIG linear regulator, see Section 16.3.2.2.

16.3 Input/Output Terminal Characteristics

Note:

For all I/O terminal characteristics:

- Current drawn into a pin is defined as positive; current supplied out of a pin is defined as negative.

16.3.1 Regulators: Available For External Use

16.3.1.1 1.8V Switch-mode Regulator

1.8V Switch-mode Regulator	Min	Typ	Max	Unit
Input voltage	2.80	3.70	4.25	V
Output voltage	1.70	1.80	1.90	V
Normal Operation				
Transient settling time	-	30	-	µs
Load current	-	-	185	mA
Current available for external use, stereo audio with 16Ω load ^(a)	-	-	25	mA
Peak conversion efficiency ^(b)	-	90	-	%
Switching frequency	3.63	4.00	4.00	MHz
Inductor saturation current, stereo and 16Ω load	250	-	-	mA
Inductor ESR	0.1	0.3	0.8	Ω
Low-power Mode, Automatically Entered in Deep Sleep				
Transient settling time	-	200	-	µs
Load current	0.005	-	5	mA
Current available for external use	-	-	5	mA
Peak conversion efficiency	-	85	-	%
Switching frequency	100	-	200	kHz

^(a) More current available for audio loads above 16Ω.

^(b) Conversion efficiency depends on inductor selection.

Note:

The regulator undershoots and overshoots when transitioning between modes.

16.3.1.2 Combined 1.8V and 1.35V Switch-mode Regulator

Combined 1.8V and 1.35V Switch-mode Regulator	Min	Typ	Max	Unit
Input voltage	2.80	3.70	4.25	V
Output voltage	1.70	1.80	1.90	V
Normal Operation				
Transient settling time	-	30	-	µs
Load current	-	-	340	mA
Current available for external use, stereo audio with 16Ω load ^(a)	-	-	25	mA
Peak conversion efficiency ^(b)	-	90	-	%
Switching frequency	3.63	4.00	4.00	MHz
Inductor saturation current, stereo and 16Ω load	400	-	-	mA
Inductor ESR	0.1	0.3	0.8	Ω
Low-power Mode, Automatically Entered in Deep Sleep				
Transient settling time	-	200	-	µs
Load current	0.005	-	5	mA
Current available for external use	-	-	5	mA
Peak conversion efficiency	-	85	-	%
Switching frequency	100	-	200	kHz

^(a) More current available for audio loads above 16Ω.

^(b) Conversion efficiency depends on inductor selection.

Note:

The regulator undershoots and overshoots when transitioning between modes.

16.3.1.3 Bypass LDO Regulator

Normal Operation	Min	Typ	Max	Unit
Input voltage	4.25 ^(a)	5.00	6.50 ^(b)	V
Output voltage ($V_{in} > 4.25V$)	3.20	3.30	3.40	V
Output current ($V_{in} > 4.75V$)	-	-	250	mA

^(a) Minimum input voltage of 4.25 V is required for full specification, regulator operates at reduced load current from 3.1 V.

^(b) Standard maximum input voltage is 5.75 V, a 6.50 V maximum depends on firmware version and implementation of over-temperature protection software, for more information contact CSR.

16.3.2 Regulators: For Internal Use Only

16.3.2.1 1.35V Switch-mode Regulator

1.35V Switch-mode Regulator	Min	Typ	Max	Unit
Input voltage	2.80	3.70	4.25	V
Output voltage	1.30	1.35	1.40	V
Normal Operation				
Transient settling time	-	30	-	μs
Load current	-	-	160	mA
Current available for external use	-	-	0	mA
Peak conversion efficiency ^(a)	-	88	-	%
Switching frequency	3.63	4.00	4.00	MHz
Inductor saturation current, stereo and 16 Ω load	220	-	-	mA
Inductor ESR	0.1	0.3	0.8	Ω
Low-power Mode, Automatically Entered in Deep Sleep				
Transient settling time	-	200	-	μs
Load current	0.005	-	5	mA
Current available for external use	-	-	0	mA
Peak conversion efficiency	-	-	85	%
Switching frequency	100	-	200	kHz

^(a) Conversion efficiency depends on inductor selection.

Note:

The regulator undershoots and overshoots when transitioning between modes.

16.3.2.2 Low-voltage VDD_DIG Linear Regulator

Normal Operation	Min	Typ	Max	Unit
Input voltage	1.30	1.35 or 1.80	1.95	V
Output voltage ^(a)	0.80	0.90 / 1.20	1.25	V
Internal load current	-	-	80	mA

^(a) Output voltage level is software controlled

16.3.2.3 Low-voltage VDD_AUX Linear Regulator

Normal Operation	Min	Typ	Max	Unit
Input voltage	1.70	1.80	1.95	V
Output voltage	1.30	1.35	1.45	V
Internal load current	-	-	5	mA

16.3.2.4 Low-voltage VDD_ANA Linear Regulator

Normal Operation	Min	Typ	Max	Unit
Input voltage	1.70	1.80	1.95	V
Output voltage	1.30	1.35	1.45	V
Load current	-	-	60	mA

16.3.3 Regulator Enable

VREGENABLE, Switching Threshold	Min	Typ	Max	Unit
Rising threshold	-	-	1.0	V

16.3.4 Battery Charger

Battery Charger	Min	Typ	Max	Unit
Input voltage, VCHG	4.75 / 3.10 ^(a)	5.00	5.75 / 6.50 ^(b)	V

^(a) Reduced specification from 3.1V to 4.75V. Full specification >4.75V.

^(b) Standard maximum input voltage is 5.75V, a 6.50V maximum depends on firmware version and implementation of over-temperature protection software, for more information contact CSR.

Trickle Charge Mode	Min	Typ	Max	Unit
Charge current I_{trickle} , as percentage of fast charge current	8	10	12	%
V_{fast} rising threshold	-	2.9	-	V
V_{fast} rising threshold trim step size	-	0.1	-	V
V_{fast} falling threshold	-	2.8	-	V

Fast Charge Mode	Min	Typ	Max	Unit	
Charge current during constant current mode, I_{fast}	Max, headroom > 0.55V	194	200	206	mA
	Min, headroom > 0.55V	-	10	-	mA
Reduced headroom charge current, as a percentage of I_{fast}	Mid, headroom = 0.15V	50	-	100	%
Charge current step size	-	10	-	mA	
V_{float} threshold, calibrated	4.16	4.20	4.24	V	
Charge termination current I_{term} , as percentage of I_{fast}	7	10	20	%	

Standby Mode	Min	Typ	Max	Unit
Voltage hysteresis on VBAT, V_{hyst}	100	-	150	mV

Error Charge Mode	Min	Typ	Max	Unit
Headroom ^(a) error falling threshold	-	50	-	mV

^(a) Headroom = VCHG - VBAT

External Charge Mode ^(a)	Min	Typ	Max	Unit
Fast charge current, I_{fast}	200	-	500	mA
Control current into CHG_EXT	0	-	20	mA
Voltage on CHG_EXT	0	-	5.75 / 6.50 ^(b)	V
External pass device h_{fe}	25	50	250	-
Sense voltage, between VBAT_SENSE and VBAT at maximum current	195	200	205	mV

^(a) In the external mode, the battery charger meets all the previous charger electrical characteristics and the additional or superseded electrical characteristics are listed in this table.

^(b) Standard maximum input voltage is 5.75 V, a 6.50 V maximum depends on firmware version and implementation of over-temperature protection software, for more information contact CSR.

16.3.5 Reset

Power-on Reset	Min	Typ	Max	Unit
VDD_DIG falling threshold (active mode)	-	0.97	-	V
VDD_DIG rising threshold (active mode)	-	1.10	-	V
VDD_DIG hysteresis (active mode)	-	130	-	mV
VDD_DIG falling threshold (deep sleep mode)	-	0.77	-	V
VDD_AUX_1V8 falling threshold ^(a)	-	1.46	-	V
VDD_AUX_1V8 rising threshold	-	1.65	-	V
VDD_AUX_1V8 hysteresis	-	190	-	mV

^(a) The 1.8V switch-mode power supply rail can briefly drop to >1.3V during deep sleep exit. This is expected behaviour and does not cause a reset.

16.3.6 USB

USB	Min	Typ	Max	Unit
VDD_USB for correct USB operation	3.10	3.30	3.60	V
Input Threshold				
V _{IL} input logic level low	-	-	0.30 x VDD_USB	V
V _{IH} input logic level high	0.70 x VDD_USB	-	-	V
Output Voltage Levels to Correctly Terminated USB Cable				
V _{OL} output logic level low	0	-	0.2	V
V _{OH} output logic level high	2.80	-	VDD_USB	V

16.3.7 Clocks

Crystal Oscillator	Min	Typ	Max	Unit
Frequency	19.2	26	32	MHz
External crystal load capacitance	-	0	-	pF
On-chip crystal load capacitance	-	9	-	pF
Frequency stability	-	-	±20	ppm
Transconductance	2	-	-	mS

External Clock	Min	Typ	Max	Unit
Input frequency ^(a)	19.2	26	40	MHz
Clock input level ^(b)	0.2	0.4	VDD_AUX	V pk-pk
Edge jitter (allowable jitter), at zero crossing	-	-	10	ps rms
XTAL_IN input impedance	30	-	-	kΩ
XTAL_IN input capacitance	-	-	1	pF
DC level	-0.4	-	VDD_AUX + 0.4	V

^(a) Clock input is any frequency from 19.2 MHz to 40 MHz (default 26 MHz) in steps of 250 kHz plus CDMA/3G TCXO frequencies of 19.2, 19.44, 19.68, 19.8 and 38.4 MHz.

^(b) Clock input is either sinusoidal or square wave. If the peaks of the signal are below VSS_BT_LO_AUX or above VDD_AUX. A DC blocking capacitor is required between the signal and XTAL_IN.

16.3.8 Stereo Codec: Analogue to Digital Converter

Analogue to Digital Converter						
Parameter	Conditions	Min	Typ	Max	Unit	
Resolution	-	-	16	-	Bits	
Input Sample Rate, F_{sample}	-	8	-	96	kHz	
SNR	$f_{\text{in}} = 1\text{kHz}$ $B/W = 20\text{Hz} \rightarrow F_{\text{sample}}/2$ (20kHz max) A-Weighted $\text{THD+N} < 0.1\%$ $1.6V_{\text{pk-pk}}$ input	F_{sample}				
		8kHz	-	93	-	dB
		16kHz	-	92	-	dB
		32kHz	-	92	-	dB
		44.1kHz	-	92	-	dB
		48kHz	-	92	-	dB
THD+N	$f_{\text{in}} = 1\text{kHz}$ $B/W = 20\text{Hz} \rightarrow F_{\text{sample}}/2$ (20kHz max) $1.6V_{\text{pk-pk}}$ input	F_{sample}				
		8kHz	-	0.004	-	%
		48kHz	-	0.008	-	%
Digital gain	Digital gain resolution = 1/32	-24	-	21.5	dB	
Analogue gain	Pre-amplifier setting = 0dB, 9dB, 21dB or 30dB Analogue setting = -3dB to 12dB in 3dB steps	-3	-	42	dB	
Stereo separation (crosstalk)	Measurement bandwidth = 20Hz to 20kHz Amplitude response = RMS No weighting Input amplitude = 300mVrms, 20Hz, 1kHz, 20kHz tones, 48kHz sample rate Analogue gain set to 2, digital gain set to 0	-	-89	-	dB	

16.3.9 Stereo Codec: Digital to Analogue Converter

Digital to Analogue Converter							
Parameter	Conditions	Min	Typ	Max	Unit		
Resolution	-	-	16	-	Bits		
Output Sample Rate, F_{sample}	-	8	-	192	kHz		
SNR	$f_{\text{in}} = 1\text{kHz}$ B/W = 20Hz–20kHz A-Weighted THD+N < 0.01% 0dBFS input	F_{sample}	Load				
		48kHz	100k Ω	-	96	-	dB
		48kHz	32 Ω	-	96	-	dB
		48kHz	16 Ω	-	96	-	dB
THD+N	$f_{\text{in}} = 1\text{kHz}$ B/W = 20Hz–20kHz 0dBFS input	F_{sample}	Load				
		8kHz	100k Ω	-	0.002	-	%
		8kHz	32 Ω	-	0.002	-	%
		8kHz	16 Ω	-	0.003	-	%
		48kHz	100k Ω	-	0.003	-	%
		48kHz	32 Ω	-	0.003	-	%
		48kHz	16 Ω	-	0.004	-	%
Digital Gain	Digital Gain Resolution = 1/32	-24	-	21.5	dB		
Analogue Gain	Analogue Gain Resolution = 3dB	-21	-	0	dB		
Output voltage	Full-scale swing (differential)	-	-	778	mV rms		
Stereo separation (crosstalk)	Measurement bandwidth = 20Hz to 20kHz Amplitude response = RMS No weighting Input amplitude = 0dBFS, 20Hz, 1kHz, 20kHz tones, 48kHz sample rate Analogue gain set to 7, digital gain set to 0	-	-88	-	dB		

16.3.10 Digital

Digital Terminals	Min	Typ	Max	Unit
Input Voltage				
V _{IL} input logic level low	-0.4	-	0.4	V
V _{IH} input logic level high	0.7 x VDD	-	VDD + 0.4	V
Tr/Tf	-	-	25	ns
Output Voltage				
V _{OL} output logic level low, I _{OL} = 4.0mA	-	-	0.4	V
V _{OH} output logic level high, I _{OH} = -4.0mA	0.75 X VDD	-	-	V
Tr/Tf	-	-	5	ns
Input and Tristate Currents				
Strong pull-up	-150	-40	-10	μA
Strong pull-down	10	40	150	μA
Weak pull-up	-5	-1.0	-0.33	μA
Weak pull-down	0.33	1.0	5.0	μA
C _I Input Capacitance	1.0	-	5.0	pF

16.3.11 LED Driver Pads

LED Driver Pads	Min	Typ	Max	Unit
Current, I _{PAD}	High impedance state	-	5	μA
	Current sink state	-	10	mA
LED pad voltage, V _{PAD}	I _{PAD} = 10mA	-	0.55	V
LED pad resistance	V _{PAD} < 0.5V	-	40	Ω
V _{OL} output logic level low ^(a)	-	0	-	V
V _{OH} output logic level high ^(a)	-	0.8	-	V
V _{IL} input logic level low	-	0	-	V
V _{IH} input logic level high	-	0.8	-	V

^(a) LED output port is open-drain and requires a pull-up

16.3.12 Auxiliary ADC

Auxiliary ADC		Min	Typ	Max	Unit
Resolution		-	-	10	Bits
Input voltage range ^(a)		0	-	VDD_AUX	V
Accuracy (Guaranteed monotonic)	INL	-1	-	1	LSB
	DNL	0	-	1	LSB
Offset		-1	-	1	LSB
Gain error		-0.8	-	0.8	%
Input bandwidth		-	100	-	kHz
Conversion time		1.38	1.69	2.75	µs
Sample rate ^(b)		-	-	700	Samples/s

^(a) LSB size = VDD_AUX/1023

^(b) The auxiliary ADC is accessed through a VM function. The sample rate given is achieved as part of this function.

16.3.13 Auxiliary DAC

Auxiliary DAC		Min	Typ	Max	Unit
Resolution		-	-	10	Bits
Supply voltage, VDD_AUX		1.30	1.35	1.40	V
Output voltage range		0	-	VDD_AUX	V
Full-scale output voltage		1.30	1.35	1.40	V
LSB size		0	1.32	2.64	mV
Offset		-1.32	0	1.32	mV
Integral non-linearity		-1	0	1	LSB
Settling time ^(a)		-	-	250	ns

^(a) The settling time does not include any capacitive load

Important Note:

Access to the auxiliary DAC is firmware-dependent, for more information about its availability contact CSR.

16.4 ESD Protection

Apply ESD static handling precautions during manufacturing.

Table 16.1 shows the ESD handling maximum ratings.

Condition	Class	Max Rating
Human Body Model Contact Discharge per ANSI/ESDA/JEDEC JS-001	2	2 kV (all pins except CHG_EXT, SMPS_1V35_SENSE and SMPS_1V8_SENSE at 1 kV)
Charged Device Model Contact Discharge per JEDEC/EIA JESD22-C101	II	200 V (all pins)

Table 16.1: ESD Handling Ratings

16.4.1 USB Electrostatic Discharge Immunity

CSR8675 BGA has integrated ESD protection on the USB_DP and USB_DN pins as detailed in IEC 61000-4-2.

Depending on the software implementation on CSR8675 BGA and the device at the far end, self-recovery of the Bluetooth link is possible if CSR8675 BGA resets on an ESD strike. This classifies CSR8675 BGA as IEC 61000-4-2 classification 2 to level 4 (8 kV contact discharge / 15 kV air discharge). If self-recovery is not implemented, CSR8675 BGA is IEC 61000-4-2 classification 3 to level 4.

Note:

Any test detailed in the IEC-61000-4-2 level 4 test specification does not damage CSR8675 BGA.

The CSR8675 BGA USB VBUS pin is protected to level 4 using an external 2.2 μ F decoupling capacitor on VCHG.

Important Note:

CSR recommends correct PCB routing and to route the VBUS track through a decoupling capacitor pad.

When the USB connector is a long way from CSR8675 BGA, place an extra 1 μ F or 2.2 μ F capacitor near the USB connector.

No components (including 22 Ω series resistors) are required between CSR8675 BGA and the USB_DP and USB_DN lines.

To recover from an unintended reset, e.g. a large ESD strike, the watchdog and reset protection feature can restart CSR8675 BGA and signal the unintended reset to the VM.

Table 16.2 summarises the level of protection.

IEC 61000-4-2 Level	ESD Test Voltage (Positive and Negative)	IEC 61000-4-2 Classification	Comments
1	2 kV contact / 2 kV air	Class 1	Normal performance within specification limits
2	4 kV contact / 4 kV air	Class 1	Normal performance within specification limits
3	6 kV contact / 8 kV air	Class 2 or class 3	Temporary degradation or operator intervention required
4	8 kV contact / 15 kV air	Class 2 or class 3	Temporary degradation or operator intervention required

Table 16.2: USB Electrostatic Discharge Protection Level



For more information contact CSR.

17 Power Consumption

DUT Role	Connection		Packet Type	Average Current	Unit
N/A	Deep sleep	With UART host connection	-	76	μA
N/A	Page scan	Page = 1280ms interval Window = 11.25ms	-	261	μA
N/A	Inquiry and page scan	Inquiry = 1280ms interval Page = 1280ms interval Window = 11.25ms	-	482	μA
Master	ACL	Sniff = 500ms, 1 attempt, 0 timeout	DH1	173	μA
Master	ACL	Sniff = 1280ms, 8 attempts, 1 timeout	DH1	150	μA
Master	SCO	Sniff = 100ms, 1 attempt, PCM	HV3	9.9	mA
Master	SCO	Sniff = 100ms, 1 attempt, mono audio codec	HV3	10.7	mA
Master	eSCO	Setting S3, sniff = 100ms, PCM	2EV3	8.0	mA
Master	eSCO	Setting S3, sniff = 100ms, PCM	3EV3	7.7	mA
Master	eSCO	Setting S3, sniff = 100ms, mono audio codec	2EV3	9.9	mA
Master	eSCO	Setting S3, sniff = 100ms, mono audio codec	3EV3	9.5	mA
Slave	ACL	Sniff = 500ms, 1 attempt, 0 timeout	DH1	182	μA
Slave	ACL	Sniff = 1280ms, 8 attempts, 1 timeout	DH1	187	μA
Slave	SCO	Sniff = 100ms, 1 attempt, PCM	HV3	10.2	mA
Slave	SCO	Sniff = 100ms, 1 attempt, mono audio codec	HV3	12.0	mA
Slave	eSCO	Setting S3, sniff = 100ms, PCM	2EV3	8.4	mA
Slave	eSCO	Setting S3, sniff = 100ms, PCM	3EV3	8.1	mA
Slave	eSCO	Setting S3, sniff = 100ms, mono audio codec	2EV3	10.3	mA
Slave	eSCO	Setting S3, sniff = 100ms, mono audio codec	3EV3	10.0	mA

Note:

Current consumption values are taken with:

- HCI only
- VBAT pin = 3.7 V
- Firmware ID = 10528
- RF TX power set to 0dBm
- No RF retransmissions in case of eSCO
- Audio gateway transmits silence when SCO/eSCO channel is open
- LEDs disconnected
- AFH off
- Pulse skipping mode disabled

18 CSR Green Semiconductor Products and RoHS Compliance

CSR confirms that CSR Green semiconductor products comply with the following regulatory requirements:

- Restriction on Hazardous Substances directive guidelines in the EU RoHS Directive 2011/65/EU¹.
- EU REACH, Regulation (EC) No 1907/2006¹:
 - List of substances subject to authorisation (Annex XIV)
 - Restrictions on the manufacture, placing on the market and use of certain dangerous substances, preparations and articles (Annex XVII). This Annex now includes requirements that were contained within EU Directive, 76/769/EEC. There are many substance restrictions within this Annex, including, but not limited to, the control of use of Perfluorooctane sulfonates (PFOS).
 - When requested by customers, notification of substances identified on the Candidate List as Substances of Very High Concern (SVHC)¹.
- POP regulation (EC) No 850/2004¹
- EU Packaging and Packaging Waste, Directive 94/62/EC¹
- Montreal Protocol on substances that deplete the ozone layer.
- Conflict minerals, Section 1502, Dodd-Frank Wall Street Reform and Consumer Protection act, which affects columbite-tantalite (coltan / tantalum), cassiterite (tin), gold, wolframite (tungsten) or their derivatives. CSR is a fabless semiconductor company: all manufacturing is performed by key suppliers. CSR have mandated that the suppliers shall not use materials that are sourced from "conflict zone mines" but understand that this requires accurate data from the EICC programme. CSR shall provide a complete EICC / GeSI template upon request.

CSR has defined the "CSR Green" standard based on current regulatory and customer requirements including free from bromine, chlorine and antimony trioxide.

Products and shipment packaging are marked and labelled with applicable environmental marking symbols in accordance with relevant regulatory requirements.

This identifies the main environmental compliance regulatory restrictions CSR specify. For more information on the full "CSR Green" standard, contact product.compliance@csr.com.

¹ Including applicable amendments to EU law which are published in the EU Official Journal, or SVHC Candidate List updates published by the European Chemicals Agency (ECHA).

19 Software

CSR8675 BGA:

- Is supplied with on-chip Bluetooth v4.1 specification qualified HCI stack firmware
- Has on-chip software that can be loaded with applications from CSR's audio development kit, see Section 19.2.1.1
- Has on-chip software that can be loaded with applications from CSR's eXtension Program

19.1 On-chip Software

19.1.1 Stand-alone CSR8675 BGA and Kalimba DSP Applications

Figure 19.1 shows the structure of the stack for running on-chip software and applications, it is built on top of the HCI stack in Section 19.1.2. The stack firmware requires no host processor, but uses a host processor for debugging etc, as Figure 19.1 shows. The software layers for the application software run on the internal MCU in a protected user-software execution environment known as a VM and the DSP application code runs from the DSP program memory RAM.

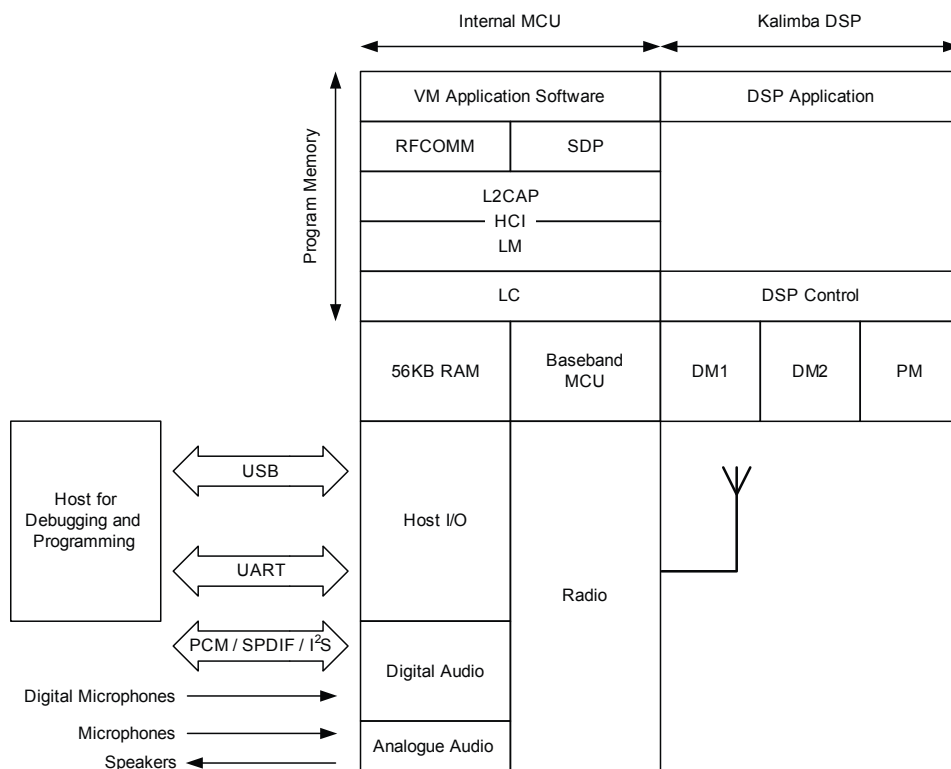

Figure 19.1: Stand-alone CSR8675 BGA and Kalimba DSP Applications

Note:

Program memory in Figure 19.1 is internal flash.

CSR provides a development kit that customers can configure to meet their audio and consumer end-product requirements.

The development kit include firmware components, applications and appropriate profile support. For more information see Section 19.2.1.

19.1.2 BlueCore HCI Stack

Figure 19.2 shows HCI stack implementation. The internal MCU runs the Bluetooth stack up to the HCI.

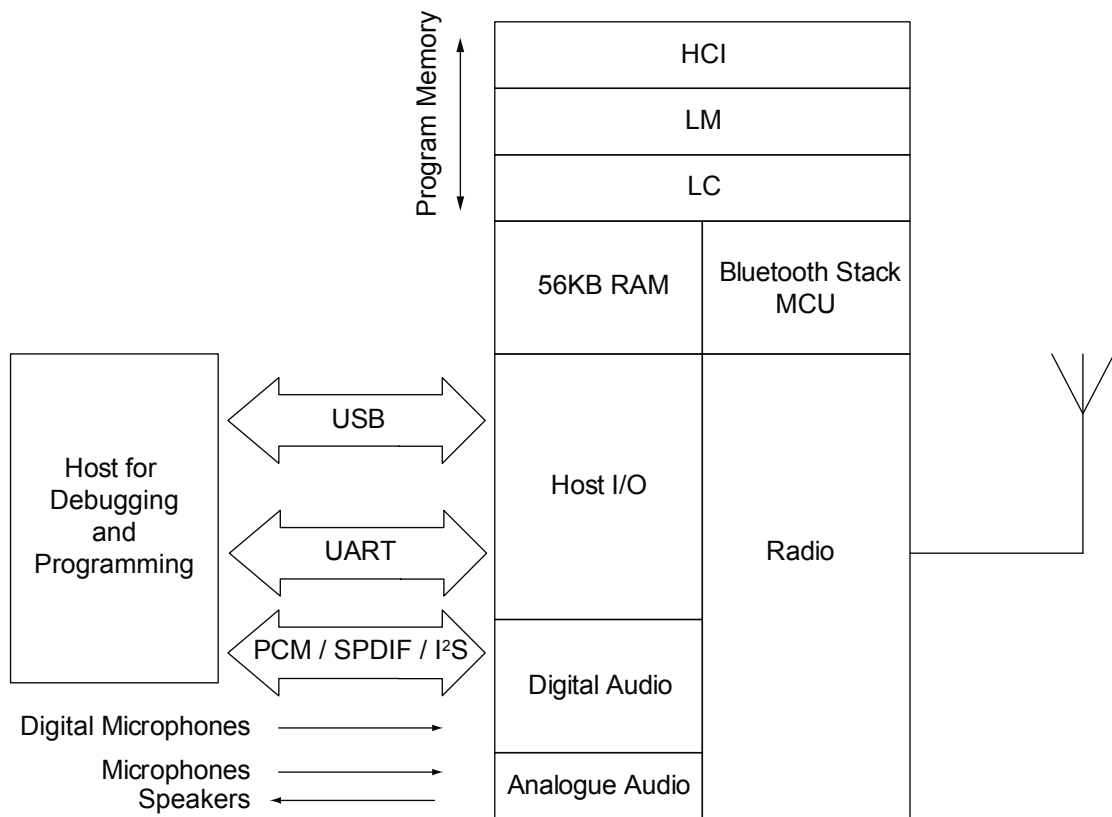

G-TW-0006097.1.1

Figure 19.2: BlueCore HCI Stack

Note:

Program Memory in Figure 19.2 is internal flash.

19.1.2.1 Latest Features of the HCI Stack

CSR8675 BGA is qualified to the Bluetooth v4.1 specification.

19.2 Off-chip Software

19.2.1 CSR8675 Development Kit

CSR's audio development kit for the CSR8675 BGA, order code DK-CSR8675-10197-1A, includes a CSR8675 BGA demonstrator board (DB-CSR8675-10200-1A) and necessary interface adapters and cables are available. In conjunction with the CSR8675 Configurator tool and other supporting utilities the development kit provides the best environment for designing audio solutions with the CSR8675 BGA.

Important Note:

The CSR8675 BGA audio development kit is subject to change and updates, for up-to-date information see www.csr.com.

19.2.1.1 Audio Development Kit Software

In conjunction with the CSR8675 audio development kit, software is available, it requires a *Bluetooth Developer's Licence* to use. CSR's current software includes:

- **Bluetooth Profiles:**
 - Bluetooth v4.1 specification support
 - HFP v1.6
 - HSP v1.2
 - A2DP v1.2
 - AVRCP v1.4
 - PBAP v1.0
 - MAP v1.0
 - SPP v1.0
- **Improved Audio Quality:**
 - CVC 1-mic far-end audio enhancements (narrowband)
 - CVC 2-mic far-end audio enhancements (narrowband)
 - CVC 1-mic far-end audio enhancements (hands-free)
 - CVC 1-mic far-end audio enhancements (wideband)
 - CVC 2-mic far-end audio enhancements (wideband)
 - CVC near-end audio enhancements
 - PLC / BEC
 - 1-mic WNR
 - 2-mic WNR
 - Sidetone
 - Frequency expansion for improved speech intelligibility
- **Music Enhancements:**
 - aptX codec technology
 - 5-band EQ
 - 3D stereo separation
 - Dynamic range control
 - Faststream codec
 - SBC decoder
 - MP3 decoder
 - AAC decoder
- **Additional Functionality:**
 - Multipoint for HFP, A2DP and advance user-cases
 - Programmable audio prompts (compressed / SBC)
 - Support for capacitive touch control
 - Support for speech recognition
 - Support for multi-language programmable audio prompts
 - CSR's proximity pairing and CSR's proximity connection
 - Multipoint support for HFP connection to 2 handsets for voice
 - Multipoint support for A2DP connection to 2 A2DP sources for music playback
 - Talk-time extension

19.2.2 eXtension Program Support

A wide range of software options is available from CSR's eXtension Program Support, see www.csr.com.

20 Tape and Reel Information

For tape and reel packing and labelling see *IC Packing and Labelling Specification*.

20.1 Tape Orientation

Figure 20.1 shows the general orientation of the CSR8675 BGA package in the carrier tape.

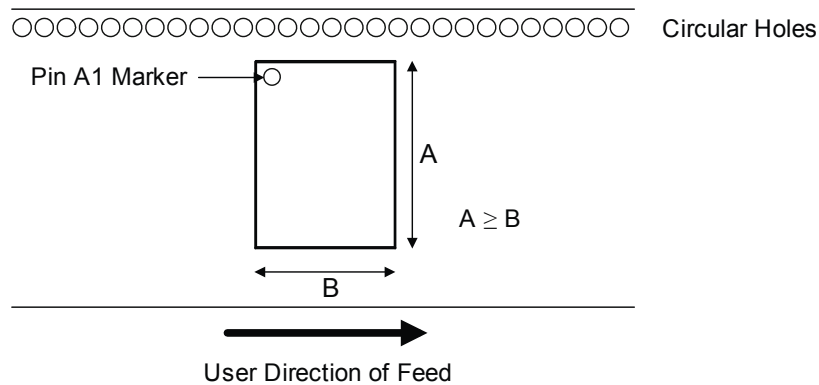

Figure 20.1: Tape Orientation

20.2 Tape Dimensions

Figure 20.2 shows the dimensions of the tape for the CSR8675 BGA.

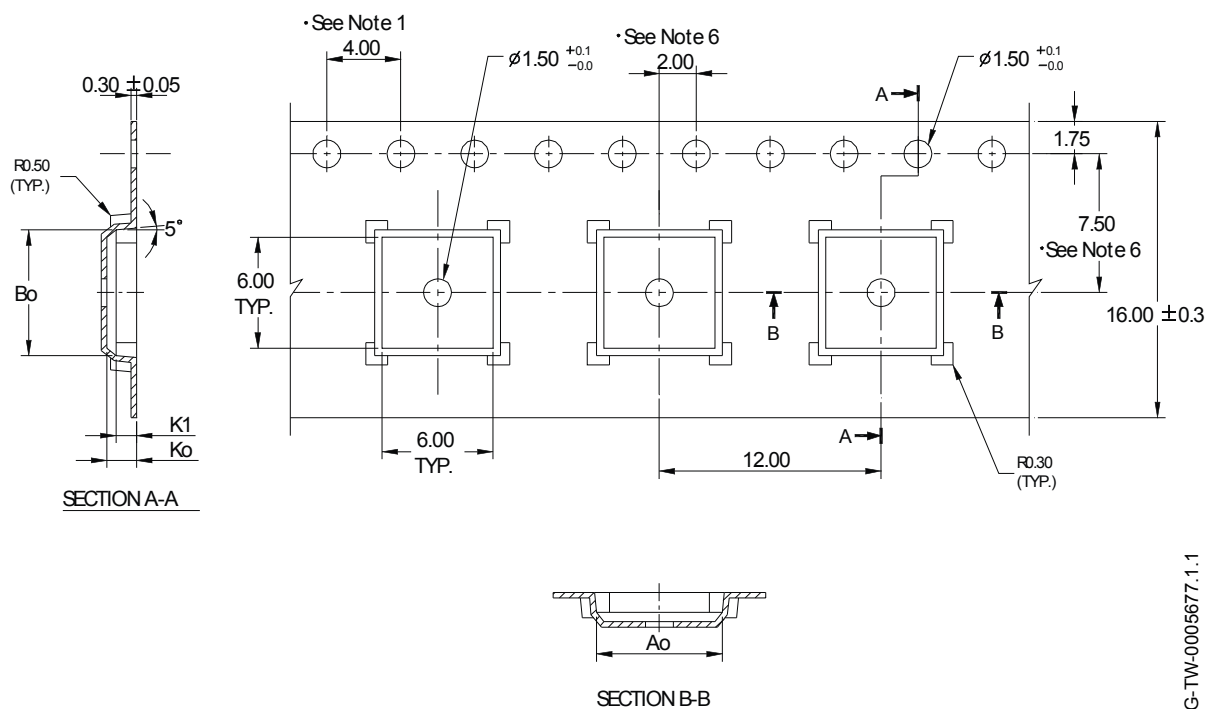
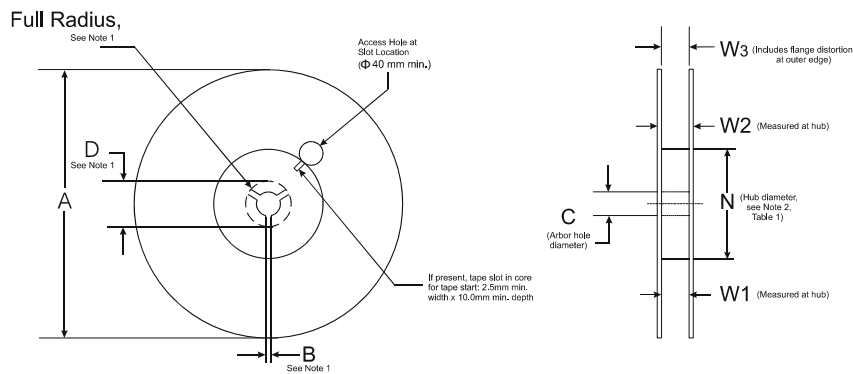

Figure 20.2: Tape Dimensions

A ₀	B ₀	K ₀	K ₁	Unit	Notes
6.80	6.80	1.60	1.10	mm	<ol style="list-style-type: none"> 10 sprocket hole pitch cumulative tolerance ± 0.2. Camber not to exceed 1mm in 100mm. Material: black polystyrene. A₀ and B₀ measured on a plane 0.3mm above the bottom of the pocket. K₀ measured from a plane on the inside bottom of the pocket to the top surface of the carrier tape. Pocket position relative to sprocket hole measured as true position of pocket, not pocket hole

20.3 Reel Information

Reel dimensions
(All dimensions in millimeters)



Notes:
1. Drive spokes optional; if used, dimensions B and D shall apply.
2. Maximum weight of reel and contents 13.6kg.

Figure 20.3: Reel Dimensions

G-TW-0000386 4.2

Package Type	Tape Width	A Max	B Max	C	D Min	N Min	W1	W2 Max	W3		Units
									Min	Max	
6.5 x 6.5 x 1 mm VFBGA	16	332	1.5	13.0 (0.5/-0.2)	20.2	50	16.4 (3.0/-0.2)	19.1	16.4	19.1	mm

20.4 Moisture Sensitivity Level

CSR8675 BGA is qualified to moisture sensitivity level MSL3 in accordance with JEDEC J-STD-020.

21 Document References

Document	Reference, Date
<i>BlueCore Audio API Specification</i>	CS-209064-DD
<i>BlueCore Bluetooth/IEEE 802.11 Coexistence Application Note</i>	CS-207808-AN
<i>BlueTest User Guide</i>	CS-102736-UG
<i>Bluetooth and USB Design Considerations</i>	CS-101412-AN
<i>Configuring the Power Supplies on CSR867x</i>	CS-204573-AN
<i>Configuring the Touch Sensor on CSR867x</i>	CS-204575-AN
<i>Core Specification of the Bluetooth System</i>	Bluetooth Specification Version 4.1, 03 December 2013
<i>CSR8675 BGA Performance Specification</i>	CS-303731-SP
<i>CVC Two Microphone Headset Design Guidelines</i>	CS-218321-DC
<i>ESDA/JEDEC Joint Standard For Electrostatic Discharge Sensitivity Testing Human Body Model (HBM) - Component Level</i>	ANSI/ESDA/JEDEC JS-001-2011
<i>Field-Induced Charged-Device Model Test Method for Electrostatic- Discharge-Withstand Thresholds of Microelectronic Components</i>	JESD22-C101E
<i>Firmware Configuration Keys for CSR8670</i>	CS-219481-AN
<i>IC Packing and Labelling Specification</i>	CS-112584-SP
<i>IEC 61000-4-2 Electromagnetic compatibility (EMC) – Part 4-2: Testing and measurement techniques – Electrostatic discharge immunity test</i>	IEC 61000-4-2, Edition 2.0, 2008-12
<i>Kalimba Architecture 5 DSP User Guide</i>	CS-318059-UG
<i>Lithium Polymer Battery Charger Calibration and Operation for CSR867x</i>	CS-204572-AN
<i>Moisture / Reflow Sensitivity Classification for Nonhermitic Solid State Surface Mount Devices</i>	IPC / JEDEC J-STD-020
<i>Selection of I²C EEPROMS for Use with BlueCore</i>	bcore-an-008P
<i>Typical Solder Reflow Profile for Lead-free Device</i>	CS-116434-AN
<i>Universal Serial Bus Specification</i>	v2.0, 27 April 2000
<i>USB Battery Charging Specification</i>	v1.1, 15 April 2009

Terms and Definitions

Term	Definition
3G	3 rd Generation of mobile communications technology
μ-law	Audio companding standard (G.711)
A-law	Audio companding standard (G.711)
A2DP	Advanced Audio Distribution Profile
AAC	Advanced Audio Coding
AC	Alternating Current
ACL	Asynchronous Connection-oriented
ADC	Analogue to Digital Converter
AES	Audio Engineering Society
AFC	Automatic Frequency Control
AFH	Adaptive Frequency Hopping
AGC	Automatic Gain Control
ALU	Arithmetic Logic Unit
AVRCP	Audio/Video Remote Control Profile
BCCMD	BlueCore CoMmanD
BCSP	BlueCore Serial Protocol
BEC	Bit Error Concealment
BIST	Built-In Self-Test
Bluetooth®	Set of technologies providing audio and data transfer over short-range radio connections
BMC	Burst Mode Controller
CDMA	Code Division Multiple Access
codec	Coder decoder
CRC	Cyclic Redundancy Check
CSR	Cambridge Silicon Radio
CVC	Clear Voice Capture
CVSD	Continuously Variable Slope Delta Modulation
DAC	Digital to Analogue Converter
DC	Direct Current
DDS	Direct Digital Synthesis
DFU	Device Firmware Upgrade
DMA	Direct Memory Access

Term	Definition
DNL	Differential Non Linearity (ADC accuracy parameter)
DSP	Digital Signal Processor (or Processing)
DUT	Device Under Test
e.g.	<i>exempli gratia</i> , for example
EBU	European Broadcasting Union
EDR	Enhanced Data Rate
EEPROM	Electrically Erasable Programmable Read Only Memory
EIA	Electronic Industries Alliance
EMC	ElectroMagnetic Compatibility
EQ	EQualiser
eSCO	extended SCO
ESD	Electrostatic Discharge
ESR	Equivalent Series Resistance
etc	<i>et cetera</i> , and the rest, and so forth
FIR	Finite Impulse Response (filter)
FSK	Frequency Shift Keying
G.722	An ITU-T standard wideband speech codec operating at 48, 56 and 64 kbps
GCI	General Circuit Interface
GSM	Global System for Mobile communications
H4DS	H4 Deep Sleep
HBM	Human Body Model
HCI	Host Controller Interface
HFP	Hands-Free Profile
HSP	HeadSet Profile
I ² C	Inter-Integrated Circuit Interface
I ² S	Inter-Integrated Circuit Sound
i.e.	<i>id est</i> , that is
I/O	Input/Output
IC	Integrated Circuit
ID	IDentifier
IEEE	Institute of Electronic and Electrical Engineers
IF	Intermediate Frequency
IIR	Infinite Impulse Response (filter)

Term	Definition
INL	Integral Non-Linearity (ADC accuracy parameter)
IQ	In-Phase and Quadrature
ISDN	Integrated Services Digital Network
JEDEC	Joint Electron Device Engineering Council (now the JEDEC Solid State Technology Association)
Kalimba	An open platform DSP co-processor, enabling support of enhanced audio applications, such as echo and noise suppression and file compression / decompression
Kb	Kilobit
LC	An inductor (L) and capacitor (C) network
LCD	Liquid-Crystal Display
LDO	Low (voltage) Drop-Out
LED	Light-Emitting Diode
LM	Link Manager
LNA	Low Noise Amplifier
LSB	Least Significant Bit (or Byte)
MAC	Multiplier and ACcumulator
MAP	Message Access Profile
Mb	Megabit
MCU	MicroController Unit
MEMS	Micro Electro Mechanical System
MIPS	Million Instructions Per Second
MISO	Master In Slave Out
MLC	MultiLayer Ceramic
MMU	Memory Management Unit
MP3	MPEG-1 audio layer 3
N/A	Not Applicable
NC	Not Connect
NSMD	Non-Solder Mask Defined
PA	Power Amplifier
PBAP	PhoneBook Access Profile
PC	Personal Computer
PCB	Printed Circuit Board
PCM	Pulse Code Modulation
PD	Pull-down
PIO	Parallel Input/Output

Term	Definition
PIO	Programmable Input/Output, also known as general purpose I/O
PLC	Packet Loss Concealment
plc	public limited company
ppm	parts per million
PS Key	Persistent Store Key
PU	Pull-Up
PWM	Pulse Width Modulation
RAM	Random Access Memory
RC	A Resistor and Capacitor network
RCA	Radio Corporation of America, normally used to refer to a RCA connector (also known as phono connector or Cinch connector)
RF	Radio Frequency
RGB	Red Green Blue
RISC	Reduced Instruction Set Computer
RoHS	Restriction of Hazardous Substances in Electrical and Electronic Equipment Directive (2002/95/EC)
RS-232	Recommended Standard-232, a TIA/EIA standard for serial transmission between computers and peripheral devices (modem, mouse, etc.)
RSSI	Received Signal Strength Indication
RX	Receive or Receiver
SBC	Sub-Band Coding
SCO	Synchronous Connection-Oriented
SIG	(Bluetooth) Special Interest Group
SMPS	Switch-Mode Power Supply
SNR	Signal-to-Noise Ratio
SoC	System On-Chip
SPDIF	Sony/Philips Digital InterFace (also IEC 958 type II, part of IEC-60958). An interface designed to transfer stereo digital audio signals between various devices and stereo components with minimal loss.
SPI	Serial Peripheral Interface
SPP	Serial Port Profile
SQIF	Serial Quad I/O Flash (interface)
SRAM	Static Random Access Memory
TBD	To Be Defined
TCXO	Temperature Compensated crystal Oscillator
THD+N	Total Harmonic Distortion and Noise

Term	Definition
TX	Transmit or Transmitter
UART	Universal Asynchronous Receiver Transmitter
Unity	Collective name for CSR's Bluetooth/Wi-Fi coexistence schemes
Unity+	CSR's advanced coexistence scheme. Extra signalling wire used in conjunction with Unity-3 or Unity-3e for improved coexistence with periodic Bluetooth activity.
Unity-3	De facto industry standard 3-wire coexistence signalling scheme
USB	Universal Serial Bus
VCO	Voltage Controlled Oscillator
VFBGA	Very thin, Fine pitch, Ball Grid Array
VM	Virtual Machine
W-CDMA	Wideband Code Division Multiple Access
WLAN	Wireless Local Area Network
WNR	Wind Noise Reduction