



S6SAL211A31SA2001, S6SAL211A31SA3001

4ch 72W LED Driver and Communication Board Operation Guide

Doc. No. 002-08632 Rev. *A

Cypress Semiconductor
198 Champion Court
San Jose, CA 95134-1709
Phone (USA): 800.858.1810
Phone (Intl): +1 408.943.2600
www.cypress.com

© Cypress Semiconductor Corporation, 2015-2016. This document is the property of Cypress Semiconductor Corporation and its subsidiaries, including Spansion LLC (“Cypress”). This document, including any software or firmware included or referenced in this document (“Software”), is owned by Cypress under the intellectual property laws and treaties of the United States and other countries worldwide. Cypress reserves all rights under such laws and treaties and does not, except as specifically stated in this paragraph, grant any license under its patents, copyrights, trademarks, or other intellectual property rights. If the Software is not accompanied by a license agreement and you do not otherwise have a written agreement with Cypress governing the use of the Software, then Cypress hereby grants you a personal, non-exclusive, nontransferable license (without the right to sublicense) (1) under its copyright rights in the Software (a) for Software provided in source code form, to modify and reproduce the Software solely for use with Cypress hardware products, only internally within your organization, and (b) to distribute the Software in binary code form externally to end users (either directly or indirectly through resellers and distributors), solely for use on Cypress hardware product units, and (2) under those claims of Cypress’s patents that are infringed by the Software (as provided by Cypress, unmodified) to make, use, distribute, and import the Software solely for use with Cypress hardware products. Any other use, reproduction, modification, translation, or compilation of the Software is prohibited.

TO THE EXTENT PERMITTED BY APPLICABLE LAW, CYPRESS MAKES NO WARRANTY OF ANY KIND, EXPRESS OR IMPLIED, WITH REGARD TO THIS DOCUMENT OR ANY SOFTWARE OR ACCOMPANYING HARDWARE, INCLUDING, BUT NOT LIMITED TO, THE IMPLIED WARRANTIES OF MERCHANTABILITY AND FITNESS FOR A PARTICULAR PURPOSE. To the extent permitted by applicable law, Cypress reserves the right to make changes to this document without further notice. Cypress does not assume any liability arising out of the application or use of any product or circuit described in this document. Any information provided in this document, including any sample design information or programming code, is provided only for reference purposes. It is the responsibility of the user of this document to properly design, program, and test the functionality and safety of any application made of this information and any resulting product. Cypress products are not designed, intended, or authorized for use as critical components in systems designed or intended for the operation of weapons, weapons systems, nuclear installations, life-support devices or systems, other medical devices or systems (including resuscitation equipment and surgical implants), pollution control or hazardous substances management, or other uses where the failure of the device or system could cause personal injury, death, or property damage (“Unintended Uses”). A critical component is any component of a device or system whose failure to perform can be reasonably expected to cause the failure of the device or system, or to affect its safety or effectiveness. Cypress is not liable, in whole or in part, and you shall and hereby do release Cypress from any claim, damage, or other liability arising from or related to all Unintended Uses of Cypress products. You shall indemnify and hold Cypress harmless from and against all claims, costs, damages, and other liabilities, including claims for personal injury or death, arising from or related to any Unintended Uses of Cypress products.

Cypress, the Cypress logo, Spansion, the Spansion logo, and combinations thereof, PSoC, CapSense, EZ-USB, F-RAM, and Traveo are trademarks or registered trademarks of Cypress in the United States and other countries. For a more complete list of Cypress trademarks, visit cypress.com. Other names and brands may be claimed as property of their respective owners.

Preface



This manual explains how to use the evaluation board. Be sure to read this manual before using the product. For this product, please consult with sales representatives or support representatives.

Handling and Use

Handling and use of this product and notes regarding its safe use are described in the manuals.

Follow the instructions in the manuals to use this product.

Keep this manual at hand so that you can refer to it anytime during use of this product.

Notice on this Document

All information included in this document is current as of the date it is issued. Such information is subject to change without any prior notice.



Please confirm the latest relevant information with the sales representatives.

Cautions



Caution of the Products Described in this Document

The following precautions apply to the product described in this manual.

 WARNING	Indicates a potentially hazardous situation which could result in death or serious injury and/or a fault in the user's system if the product is not used correctly.
 WARNING	Do not look directly at LED. There is a possibility that your eye is hurt.

Electric shock, Damage	Before performing any operation described in this manual, turn off all the power supplies to the system. Performing such an operation with the power on may cause an electric shock or device fault.
Electric shock, Damage	Once the product has been turned on, do not touch any metal part of it. Doing so may cause an electric shock or device fault.

 CAUTION	Indicates the presence of a hazard that may cause a minor or moderate injury, damages to this product or devices connected to it, or may cause to loose software resources and other properties such as data, if the device is not used appropriately.
--	--

Cuts, Damage	Before moving the product, be sure to turn off all the power supplies and unplug the cables. Watch your step when carrying the product. Do not use the product in an unstable location such as a place exposed to strong vibration or a sloping surface. Doing so may cause the product to fall, resulting in an injury or fault.
Cuts	The product contains sharp edges that are left unavoidably exposed, such as jumper plugs. Handle the product with due care not to get injured with such pointed parts.
Damage	Do not place anything on the product or expose the product to physical shocks. Do not carry the product after the power has been turned on. Doing so may cause a malfunction due to overloading or shock.
Damage	Since the product contains many electronic components, keep it away from direct sunlight, high temperature, and high humidity to prevent condensation. Do not use or store the product where it is exposed to much dust or a strong magnetic or electric field for an extended period of time. Inappropriate operating or storage environments may cause a fault.
Damage	Use the product within the ranges given in the specifications. Operation over the specified ranges may cause a fault.
Damage	To prevent electrostatic breakdown, do not let your finger or other object come into contact with the metal parts of any of the connectors. Before handling the product, touch a metal object (such as a door knob) to discharge any static electricity from your body.
Damage	When turning the power on or off, follow the relevant procedure as described in this document. Before turning the power on, in particular, be sure to finish making all the required connections. Furthermore, be sure to configure and use the product by following the instructions given in this document. Using the product incorrectly or inappropriately may cause a fault.
Damage	Because the product has no casing, it is recommended that it be stored in the original packaging. Transporting the product may cause a damage or fault. Therefore, keep the packaging materials and use them when re-shipping the product.

Contents



1. Description	6
2. S6SAL211A31-DALI-SA2 Board Specification	7
3. PIN Descriptions	8
3.1 Input/Output Connector Descriptions	8
3.2 Switch Descriptions	8
4. Setup and Verification	9
4.1 Contents in a Package	9
4.2 Evaluation with DALI Communication for S6SAL211A31SA3001	11
5. Layout	21
5.1 S6SAL211A31-DALI-SA2 Component Layout	21
5.2 S6SAL211A31-DALI-SA2 Wiring Layout	22
5.3 S6SATU03 Component Layout	24
6. Circuit Schematic	25
6.1 S6SAL211A31-DALI-SA2 Schematic	25
6.2 S6SATU03 Schematic	29
7. Component List	30
7.1 S6SAL211A31-DALI-SA2 Components List	30
7.2 S6SATU03 Components List	33
8. S6SAL211A31-DALI-SA2 Property Data	34
9. Board Picture	36
9.1 S6SAL211A31-DALI-SA2 Board Picture	36
9.2 S6SATU03 Board Picture	37
10. Ordering Information	38
Revision History	39
Document Revision History	39

1. Description



S6SAL211A31SA2001 and S6SAL211A31SA3001 are starter kit tool for DALI communication system.
A master board (S6SATU03) and a slave board (S6SAL211A31-DALI-SA2) are included in S6SAL211A31SA3001.
A slave board (S6SAL211A31-DALI-SA2) is included in S6SAL211A31SA2001.
Master board implements the communication circuits for DALI.
Slave board is LED control board of 4CH 72W for intelligent LED lighting driver IC S6AL211A31.
It is necessary to prepare a PC, 24V power supply, software, LED module and connection cable.
When using S6SAL211A31SA2001, please prepare DALI Master additionally.

Figure 1-1 DALI System Outline

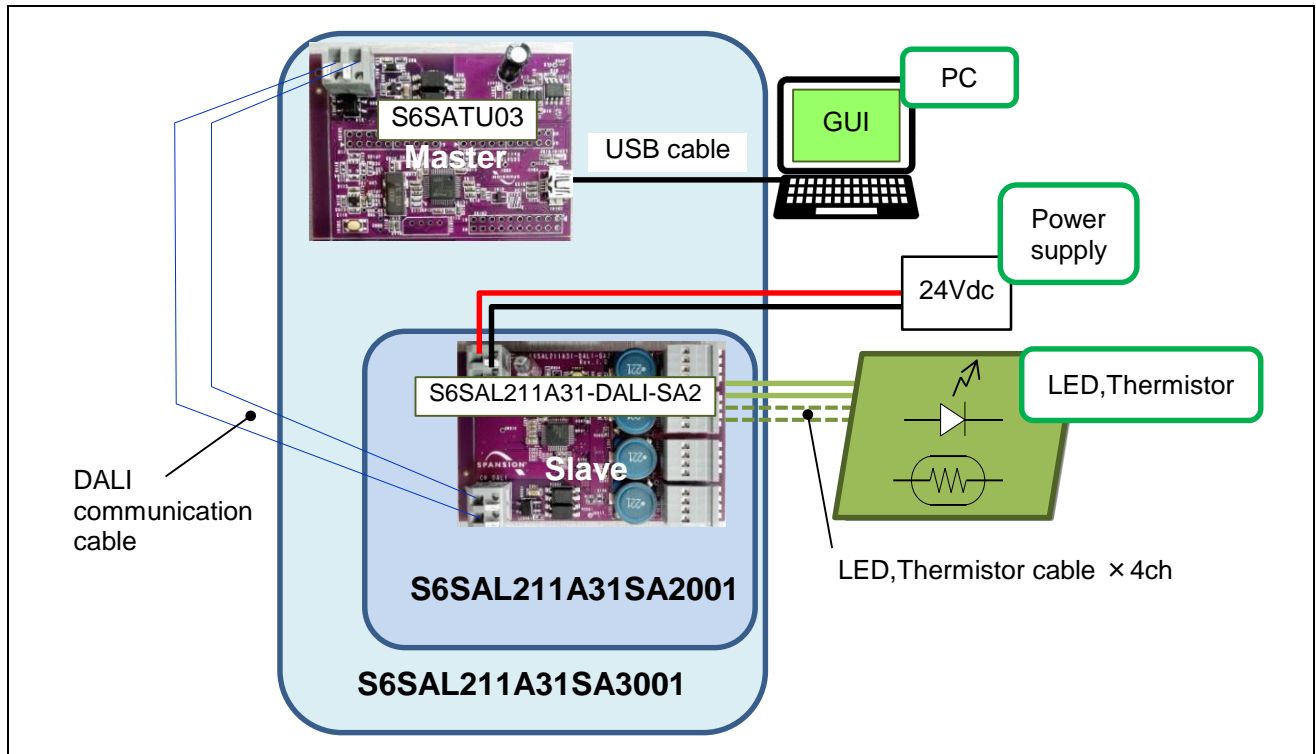

2. S6SAL211A31-DALI-SA2 Board Specification



Figure 2-1 S6SAL211A31-DALI-SA2 Board Specification

Item	Symbol	Min.	Typ.	Max.	Unit
Input voltage	VIN	22	24	26	V
Input current (VIN = 24V, ACTUAL LEVEL = 254 (max.))	IIN	-	3.1	-	A
Input current (VIN = 24V, LED OFF, Include LED001 indicator current (1.7 mA))	IINoff	-	3	-	mA
Output LED voltage	VLEDout	0	18	VIN	V
Output LED current (Each channel, ACTUAL LEVEL = 254 (max.))	ILEDout	-	1000	-	mA
Efficiency (VIN = 24V, ACTUAL LEVEL = 254 (max.))	η	-	95.8	-	%

The board size: 53 mm x 71.5 mm

POWE ON LEVEL: 0.4% (*1)

SYSTEM FAILRE LEVEL: 31% (*1)

*1: The specification of DALI is 100%, but it's changed because it's safe.

3. PIN Descriptions



3.1 Input/Output Connector Descriptions

Table 3-1 S6SAL211A31-DALI-SA2 Input/Output Pin Descriptions

Connector Symbol	I/O	Function Description
CN_VIN	I	24Vdc power supply terminal
CN101,CN201,CN301,CN401	I/O	CH1 -CH4 LED , thermistor terminal
CN_DALI	I/O	DALI communication terminal

Table 3-2 S6SATU03 Input/Output Pin Descriptions

Connector Symbol	I/O	Function Description
CN101	I/O	Mini USB connector
CN_DALI	I/O	DALI communication terminal

3.2 Switch Descriptions

Table 3-3 S6SAL211A31-DALI-SA2 Switch Descriptions

Switch	Description	Initial Setting
SW081	DALI short address physical selection Push in physical selection	-

Table 3-4 S6SATU03 Switch Descriptions

Switch	Description	Initial Setting
SW101	Reset push switch for MCU	-

4. Setup and Verification



4.1 Contents in a Package

Table 4-1 S6SAL211A31SA3001 Contents List

No.	Contents	Description	Quantity	Notes
1	S6SAL211A31-DALI-SA2	LED control board of 4CH 72W with S6AL211A31	1	-
2	S6SATU03	DALI and USB communication board with FM3	1	-
3	USB cable	USB to USB mini B cable	1	-

Table 4-2 S6SAL211A31SA2001 Contents List

No.	Contents	Description	Quantity	Notes
1	S6SAL211A31-DALI-SA2	LED control board of 4CH 72W with S6AL211A31	1	-

Figure 4-1 Contents Picture

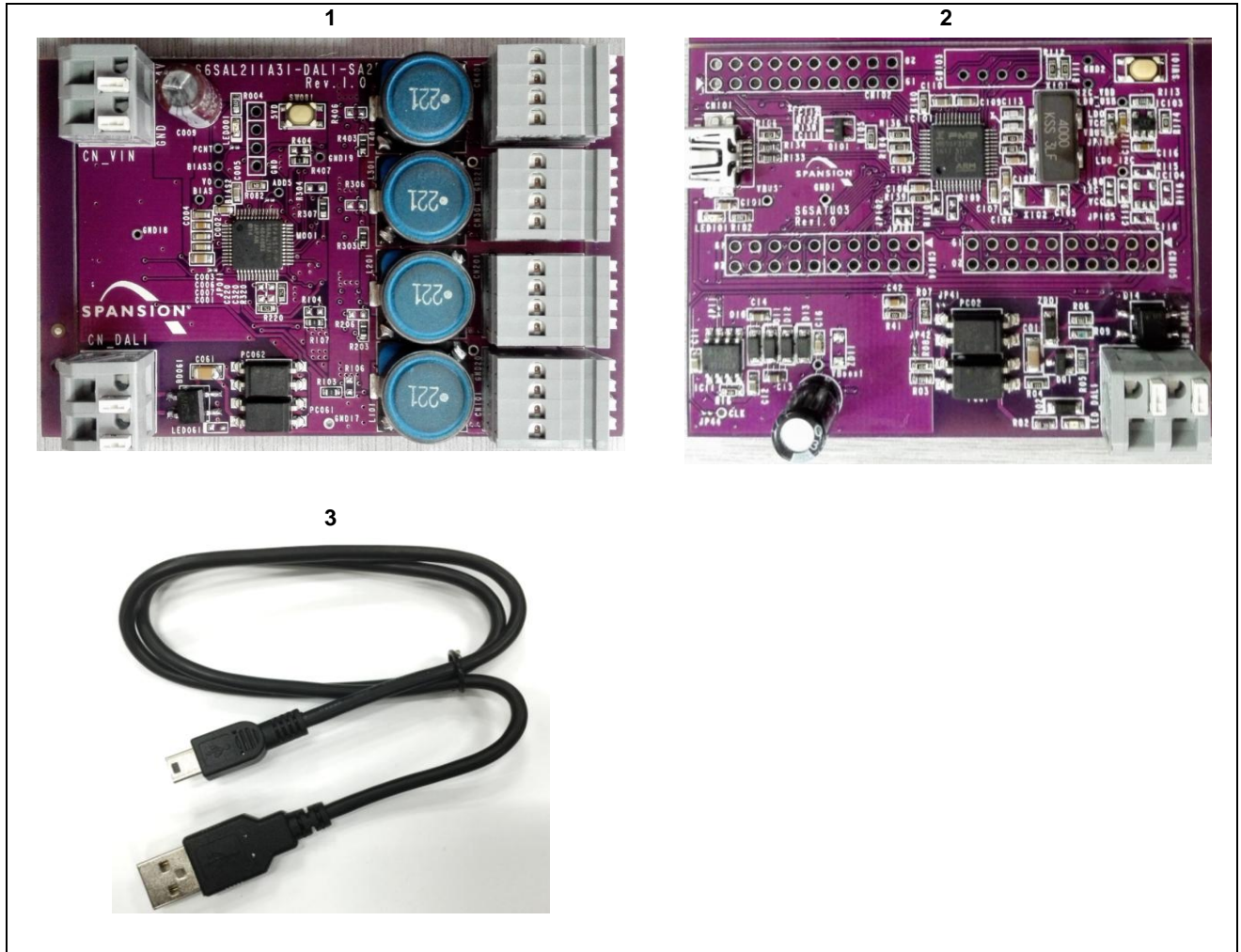

4.2 Evaluation with DALI Communication for S6SAL211A31SA3001

Using Items for Evaluation with I²C Control

■ S6SAL211A31-DALI-SA2	1pic (*1)
■ S6SATU03	1pic (*1)
■ USB cable	1pic (*1)
■ PC installed Windows7 or later OS	1pic (*2)
■ Driver file	1pic (*3)
■ DALI communication software	1pic (*3)
■ 24V power supply	1pic (*2)
■ LED module($I_F \geq 1A$, $V_F \approx 3.2V$, 5 series x 4ch)	1set (*2)
■ Connection cable	1set (*2)

*1: Included in a package.

*2: Please prepare.

*3: Please download it from our device home page,

S6AL211A31:	Driver file	install.bat in S6AL211_DALI_drivers.cab
	DALI communication software	S6AL211_DALI_GUI.exe in S6AL211_DALI_GUI.cab

4.2.1 PC Setup for S6SATU03

1. Unpack the driver file to a folder of PC running Windows 7 or later version OS, and run install.bat file.
2. Connect S6SATU03 to PC using USB cable.
3. After installed a device, open the device manager and confirm the new COM port.

Start menu → Control panel → Device manager

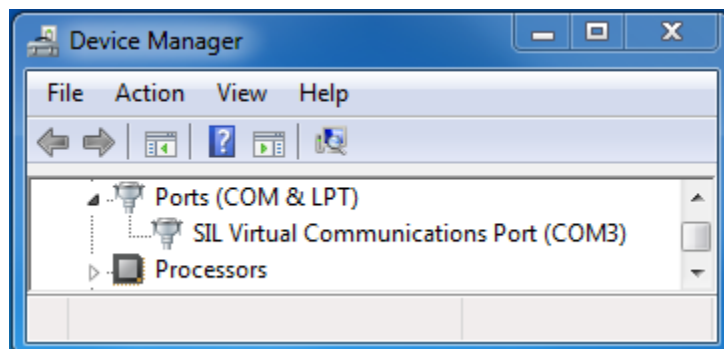

4. PC Setup is success if you can see "SIL Virtual Communication Port(COMx)" in Ports(COM & LPT).

4.2.2 Operation Check When Using S6SATU03

WARNING Do not look directly at LED. There is a possibility that your eye is hurt.

1. Connect CN_101,201,301,401 of S6SAL211A31-DALI-SA2 and LED by connection cable. *1
2. Connect CN_DALI of S6SATU03 and CN_DALI of S6SAL211A31-DALI-SA2 by DALI cable. *2
3. Connect CN101 of S6SATU03 and PC by USB cable. (LED101 near CN101 of S6SATU03 on board will shine in red.)
4. Run DALI communication software.
5. 24Vdc is applied to CN_VIN of S6SAL211A31-DALI-SA2.
6. LED of all channel are lighting. (Bright level is set POWER ON LEVEL of DALI command)
7. Send DALI command DAPC to BROADCAST ADDRESS from S6SATU03. You can control LED brightness. (Look at "Control Lighting by the broadcast")

Figure 4-2 Board Connection

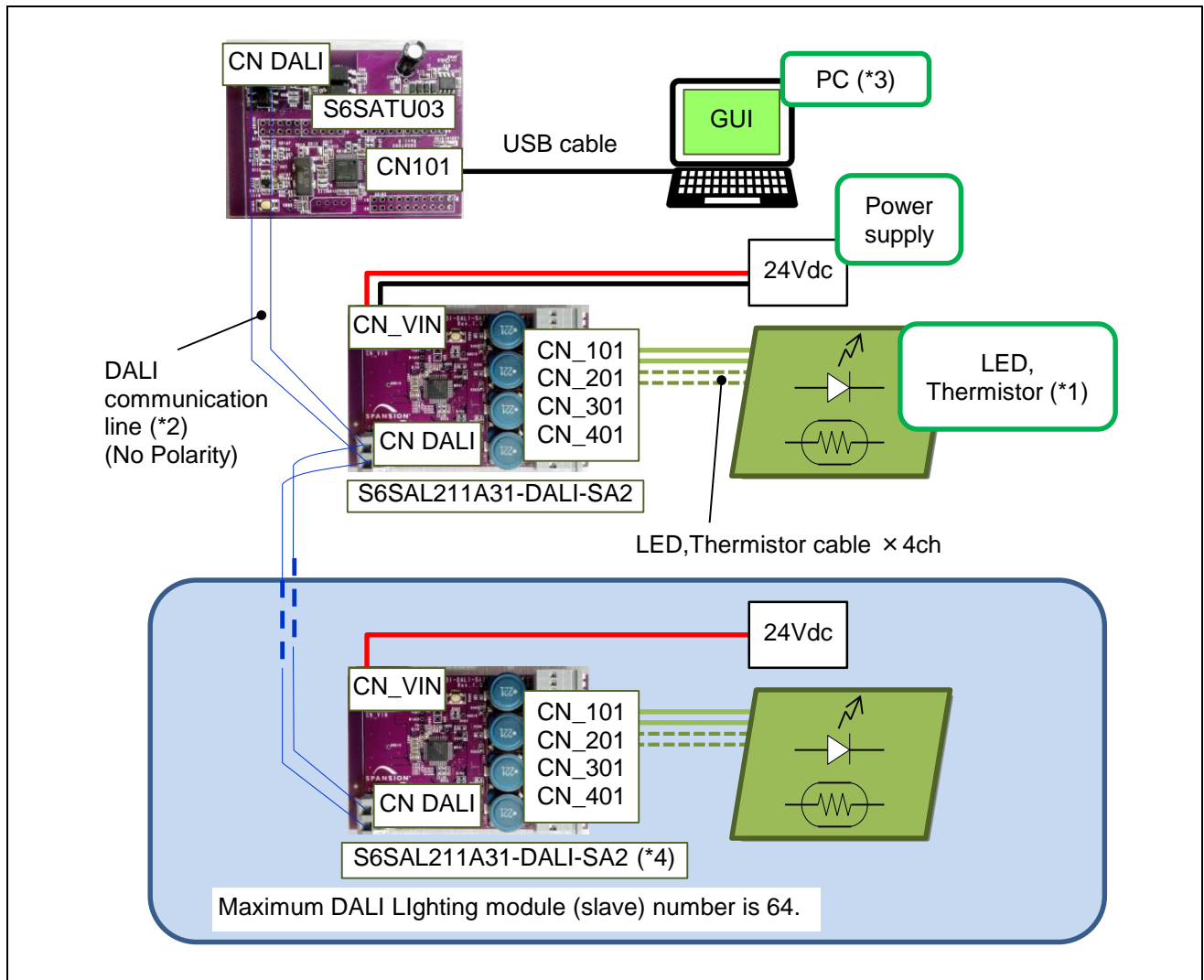

- *1: Connect LED to all CH from CN_101 to CN_401. Refer to Figure 4-3.
- *2: S6SATU03 can provide power to DALI communication lines from CN_DALI. This current limit is 50 mA (Supply voltage = 12V-20V). We must consider this current when determining the number of connected DALI Slave. We have to select the cable in consideration of the rated current and then rated voltage
- *3: Beforehand, make a setup of PC and install software.
- *4: A board of S6SAL211A31-DALI-SA2 is possible to buy as single item. (Part Number: S6SAL211A31SA2001)

Figure 4-3 Connection of 6SAL211A31-DALI-SA2 and LED

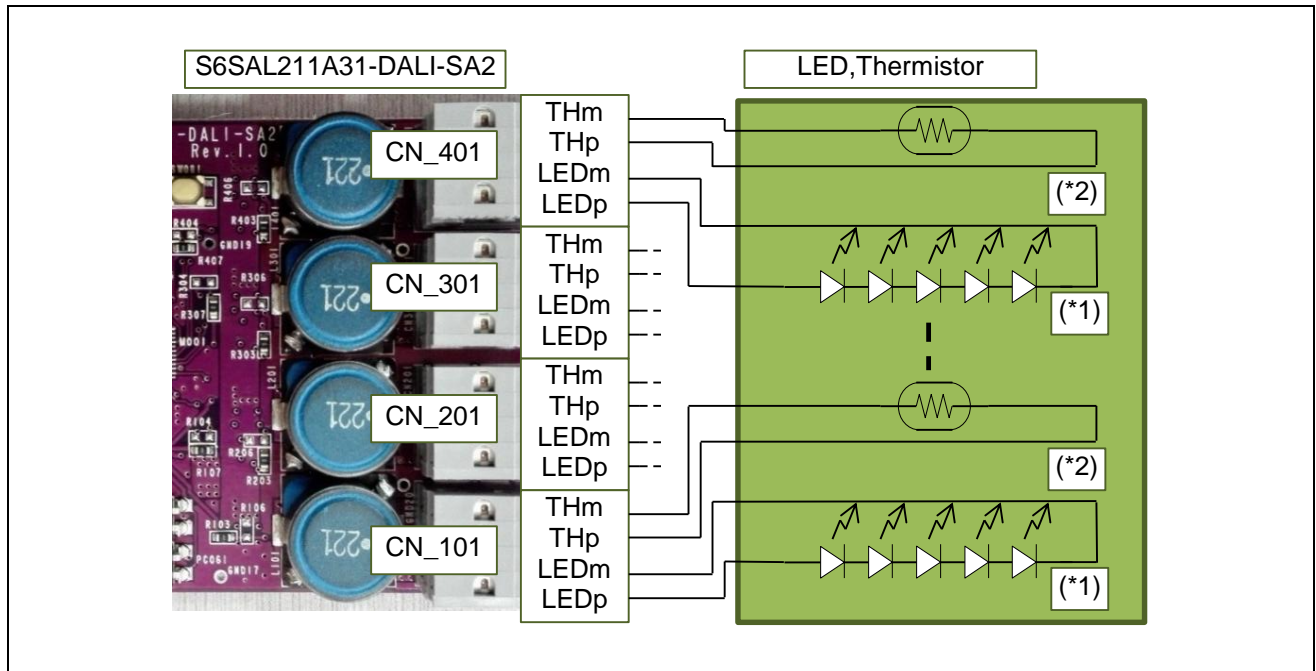

- *1: Connect LED to all CH from CN_101 to CN_401. LED module($I_F \geq 1A$, $V_F \approx 3.2V$, 5- series) Be careful about polarity.
- *2: Thermistor (THp, THm) is an option. Even if that isn't connected, a board operates.

4.2.3 GUI Control Function When Using S6SATU03

4.2.3.1 Preparing the Control GUI

Run DALI communication software (S6AL211_DALI_GUI.exe) after connecting the USB cable.

Show the message box below if the connecting GUI and DALI controller is success.

Otherwise, check USB cable connection or installation of the device driver.

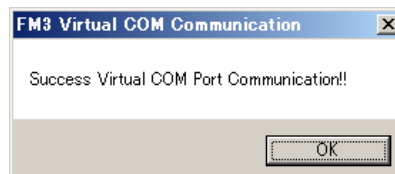

Later a few second, GUI shows the dialog box.

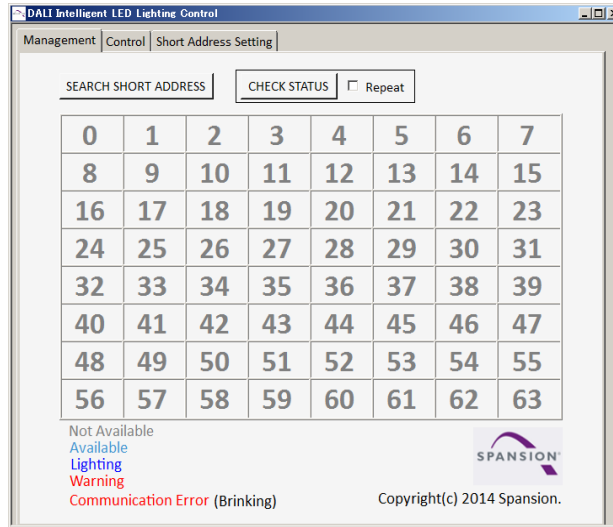

Complete preparation.

Note: Don't disconnect the USB cable while this GUI is running. Because it breaks down.

4.2.3.2 Exiting the Control GUI

Crick "x" mark in the upper right.

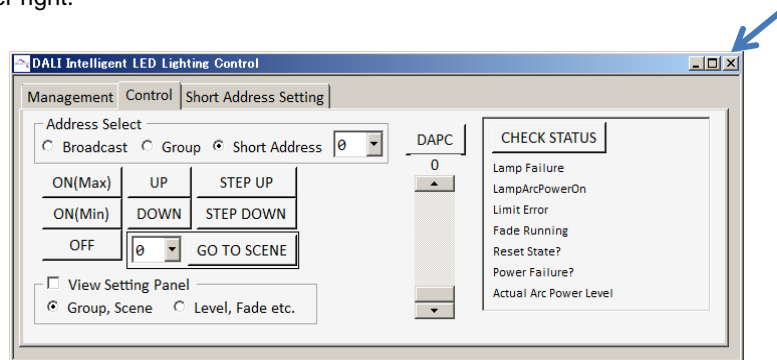

4.2.3.3 Checking State of the DALI Slave

You can check the state of connecting DALI slaves in "Management" tab.

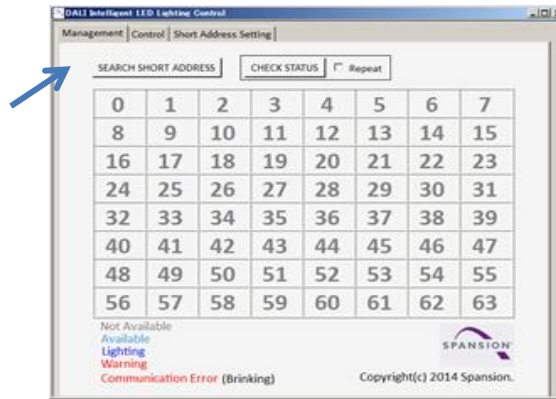

Click "SEARCH SHORT ADDRESS" button, then GUI will search some connected DALI slave.

If you see no highlighted number, Please refer to 4.2.3.6 Control Lighting by the Short Address.

And set the address.

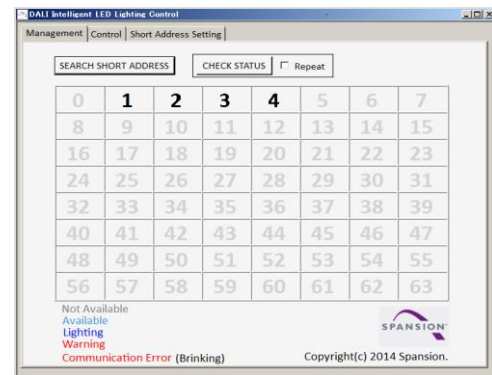
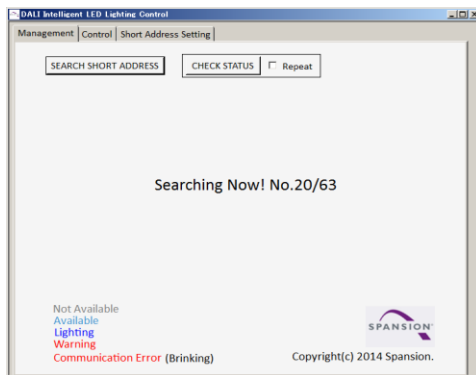

GUI found 4 DALI slaves above picture.

Click "CHECK STATUS" button, then GUI will show some connected DALI slave.

If you click "CHECK STATUS" button after checking "Repeat" check box, this GUI will update status of DALI slaves every second.

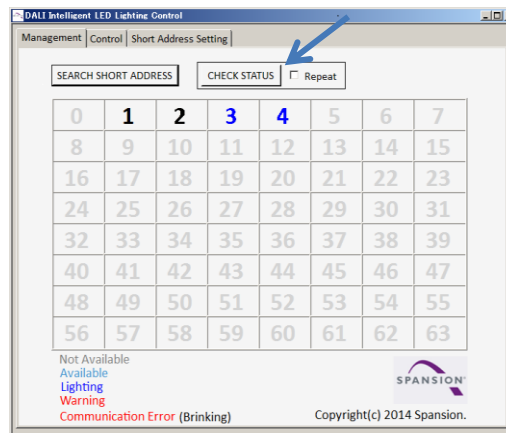

GUI shows you that 2 DALI slaves are bright above picture.

4.2.3.4 Control Lighting by the Broadcast

DALI MASTER send to all connected DALI SLAVE by the broadcast in "control" tab.

(Selected "BroadCast" Radio button in "Address Select" Group)

Click Some Button and you can control lighting.

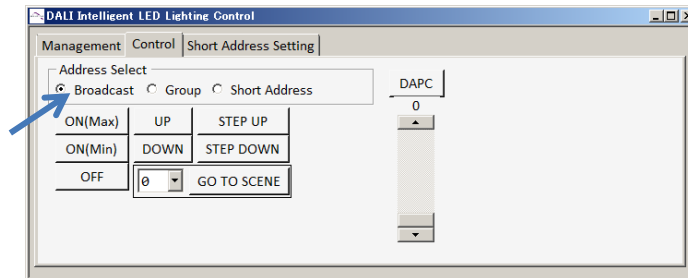

ON(Max) button:

Lighting starts at maximum level(default level 254).

ON(Min) button:

Lighting starts at minimum level(default level 1).

OFF button:

turn off lighting.

UP:

Increase lighting level at some pitch with fade.

DOWN:

reduce at some pitch with fade.

STEP UP:

One step up the lighting level.

STEP DOWN:

One step down the lighting level.

DAPC:

Direct Arc Power Control. Push this button after choosing the number (0-254) of the vertical scrollbar.

Lighting level will set on the chosen number.

GO TO SCENE:

Set the lighting level to some scene after choosing number (0-15) of the drop box at left this button.

Show later for "SCENE".

Show below message box by selecting "Broadcast" radio button in "Address Select" group.



If you select "Yes", you can use "CHECK STATUS" button and "SCENE".

*Later mention: "CHECK STATUS", "SCENE". These functions by broadcast address can work correctly in the case of connecting only one DALI slave

4.2.3.5 Control Lighting by the Group

DALI MASTER sends to each DALI group in "control" tab.

(Selected "Group" Radio button in "Address Select" Group)

Click Some Button and you can control lighting.

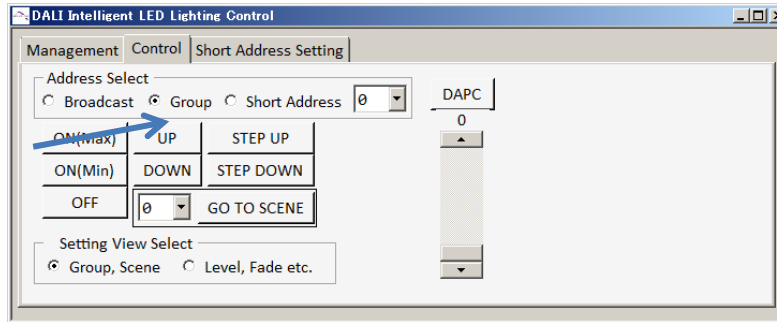

The operations of each button (ON, OFF, (STEP) UP, (STEP) DOWN, DAPC, SCENE function) are same in broadcast.

Group setting method is shown in "For the Group" of "Control Lighting by the short address".

4.2.3.6 Control Lighting by the Short Address

DALI MASTER send to the particular DALI SLAVE by the short address.

DALI SLAVE needs to choose short address number.

Crick "Short Address Setting" tab.

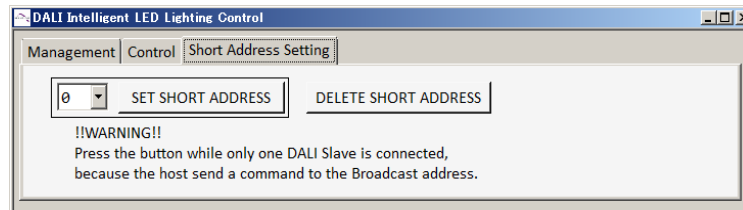

Push "SET SHORT ADDRESS" button after choosing from the drop box of left button.

Short address selection is completed.

Show blow window after choosing "Short Address" Radio button in "Address Select" Group

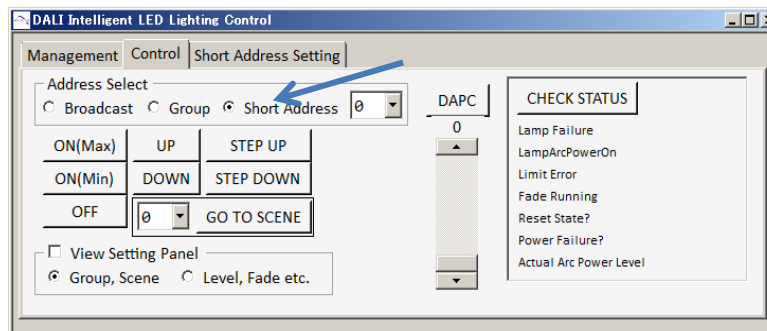

Choose the short address the drop box in "Address Select" group, and you can control the lighting that have same short address.

CHECK STATUS: Show the status of DALI slave.

View Setting Panel: You can set SCENE, GROUP and each item by checking this check box. GUI will show the dialog box below

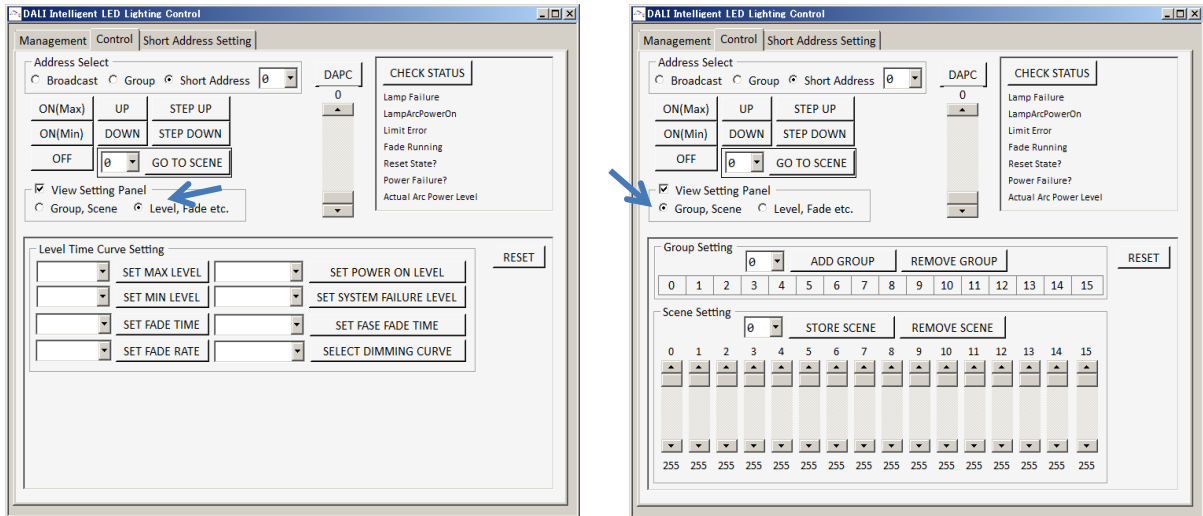

Setting Panel Level, Fade, etc.

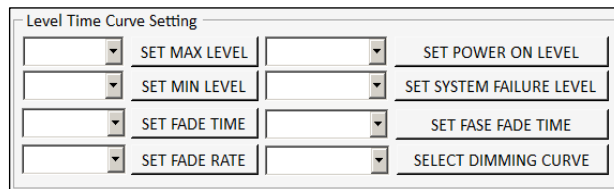

For the LEVEL

You can set each level from 1 to 254. (MAX LEVEL, MIN LEVEL, POWER ON LEVEL, SYSTEM FAILURE LEVEL).

The fade time affects DAPC and SCENE. The fade rate affects UP and DOWN.

For the FADE

You can set the fade time and the fade rate.

The fade time affects DAPC and SCENE. The fade rate affects UP and DOWN.

Setting the FADE TIME

1. Select the fade time number (No fade-90.5sec) by drop box at left "SET FADE TIME" button.
2. Push "SET FADE TIME" button.

You can confirm in running the fade function as pushing "CHECK STATUS" button.

If DALI slave is in the fade function, "Fade Running" indicates "Running".

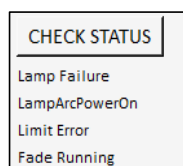

Setting the FAST FADE TIME

1. Select the fast fade time number (<25ms - 675msec) by drop box at left "SET FAST FADE TIME" button with choosing No fade by SET FADE TIME.
2. Push "SET FAST FADE TIME" button.

Setting the FADE RATE

1. Select the fade time number (1-15) by drop box at left "SET FADE RATE" button.
2. Push "SET FADE RATE" button.

Select DIMMING CURVE

You can select dimming curve, Logarithm or linear

For the SCENE

You can set lighting level as scene from 0 to 15.

You can select lighting level in 1 action as choosing the scene number without using UP, DOWN, DPAC and etc.

Using the SCENE

You can set 16 scenes lighting level by below window.

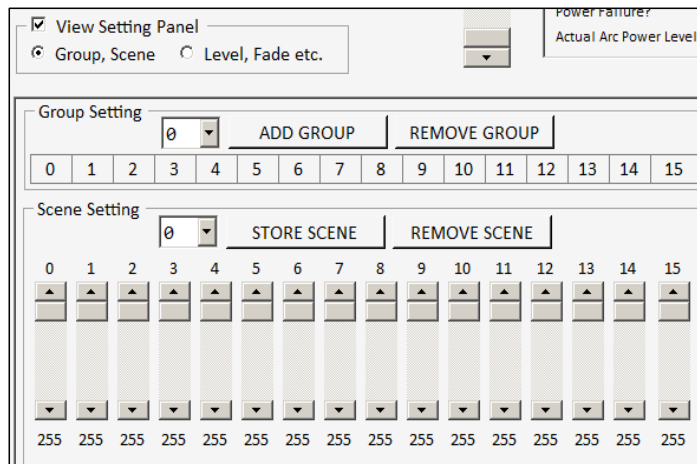

Example: Setting 125 in SCENE 2

1. Set Lighting level (0-254) to 125 by No. 2 Vscroll bar.
2. Select "2" scene number by drop box at left "STORE SCENE" button.
3. Push "STORE SCENE" button.

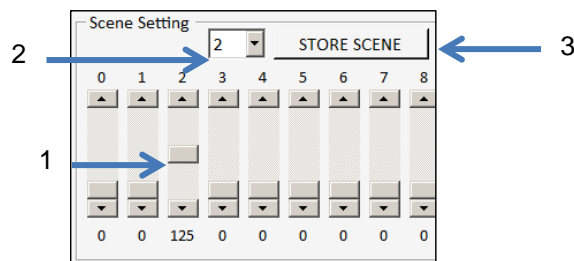

4. Select "2" scene number by drop box at left "GOTO SCENE" button.
5. Push "GO TO SCENE" button, then the lighting level will be set to 125.

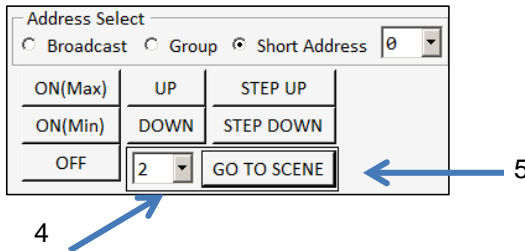

For the GROUP

You can set lighting group from 0 to 15.

Example: Setting group to No.5.

1. Select "5" group number by drop box at left "ADD GROUP" button.
2. Push "ADD GROUP" button.

You can set group more than one for one DALI slave.

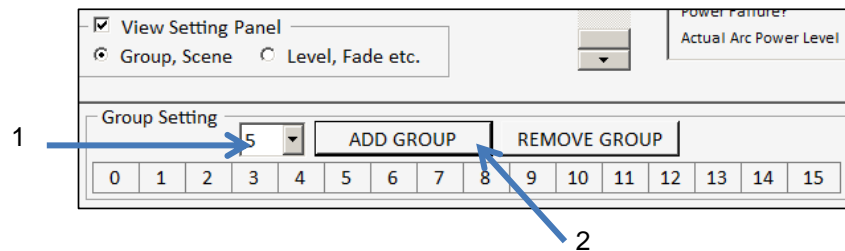

RESET Button

GUI shows "RESET" button with checking "View Setting Panel" check box.

You can reset DALI slave with pushing "RESET" button.



Note: This operation causes the lighting maximum level of LED.

Below each level are reset by "RESET" button.

(Example: MAX LEVEL=254, MIN LEVEL=1,
POWER ON LEVEL=254, SYSTEM FAILURE LEVEL=254

At the time of 6SAL211A31-DALI-SA2 shipment,
POWER ON LEVEL=1, SYSTEM FAILURE LEVEL=80)

5. Layout

5.1 S6SAL211A31-DALI-SA2 Component Layout

Figure 5-1 S6SAL211A31-DALI-SA2 Component Layout

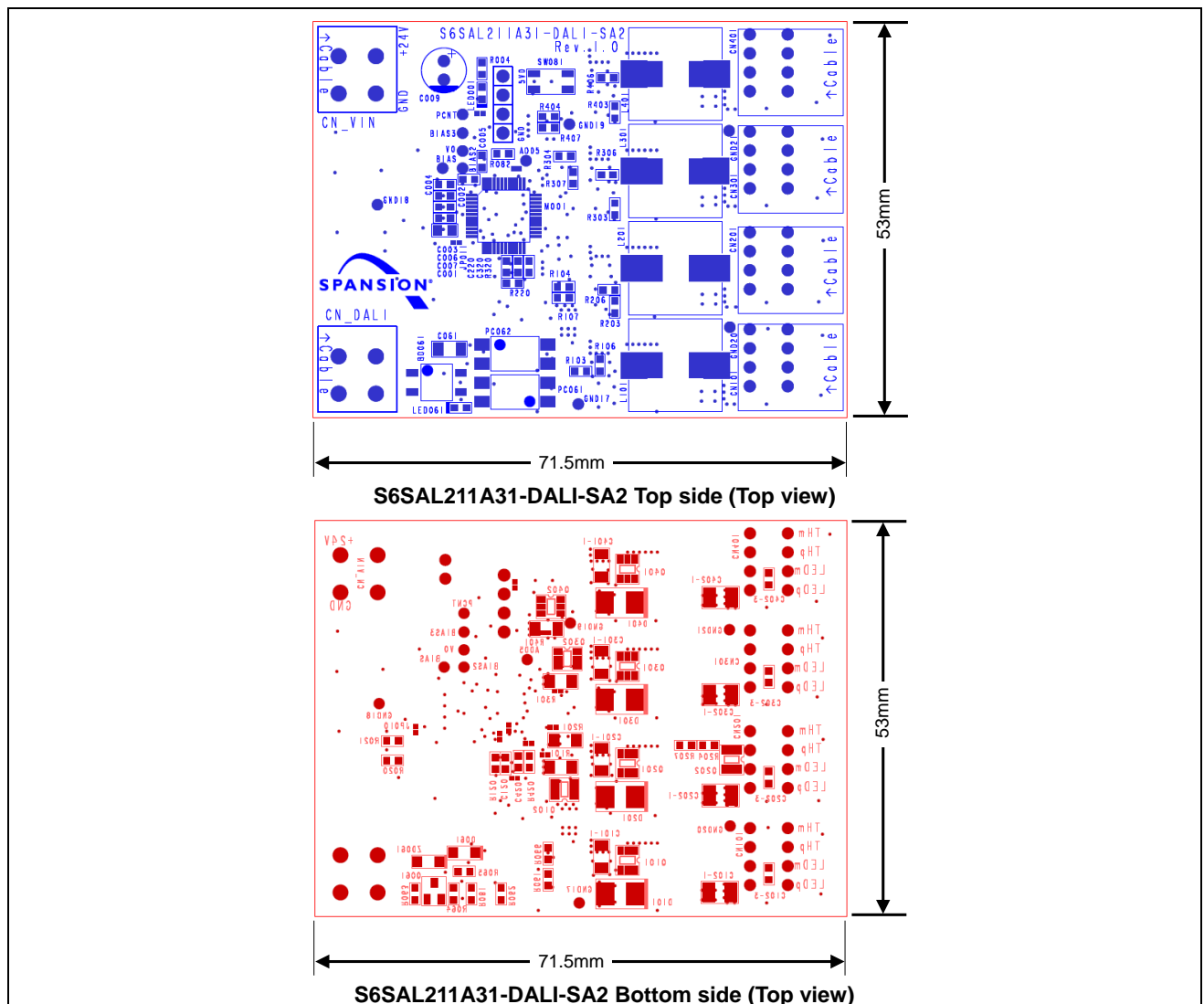

5.2 S6SAL211A31-DALI-SA2 Wiring Layout

Figure 5-2 S6SAL211A31-DALI-SA2 Wiring Layout (Layer 1, Layer 2)

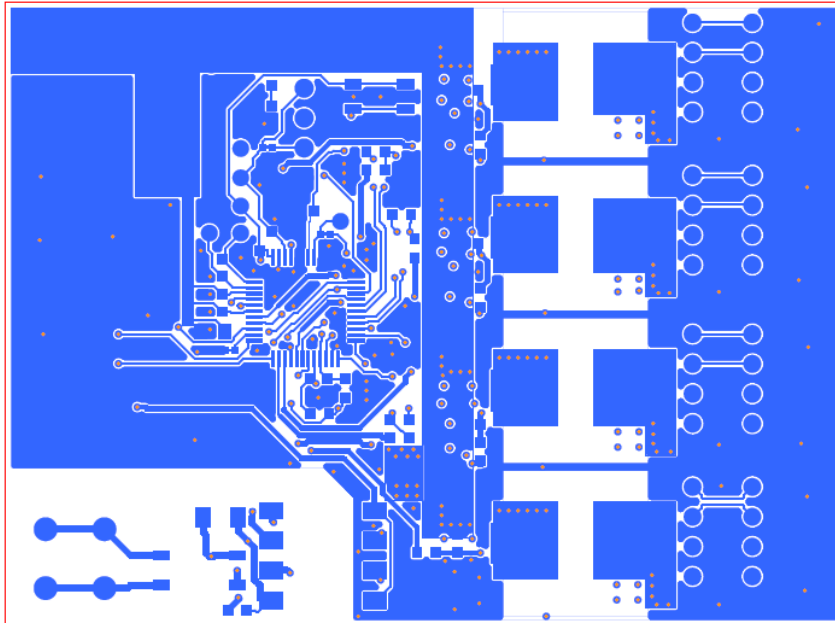

S6SAL211A31-DALI-SA2 Layer 1 (Top view)

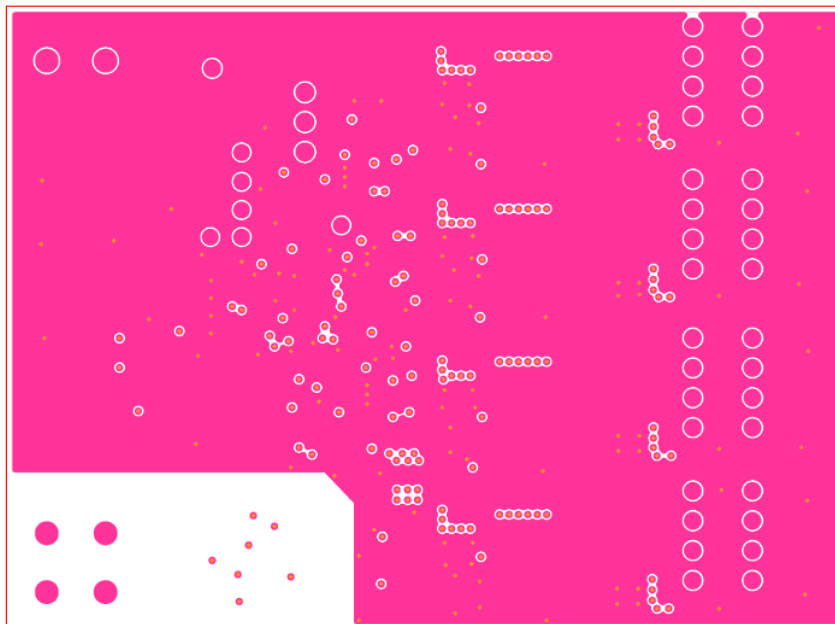

S6SAL211A31-DALI-SA2 Layer 2 (Top view)

Figure 5-3 S6SAL211A31-DALI-SA2 Wiring Layout (Layer 3, Layer 4)

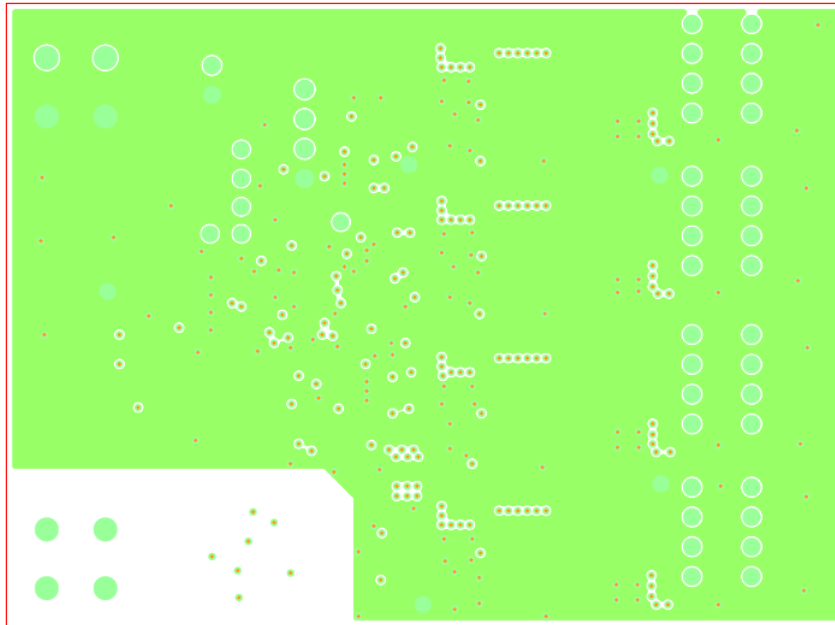

S6SAL211A31-DALI-SA2 Layer 3 (Top view)

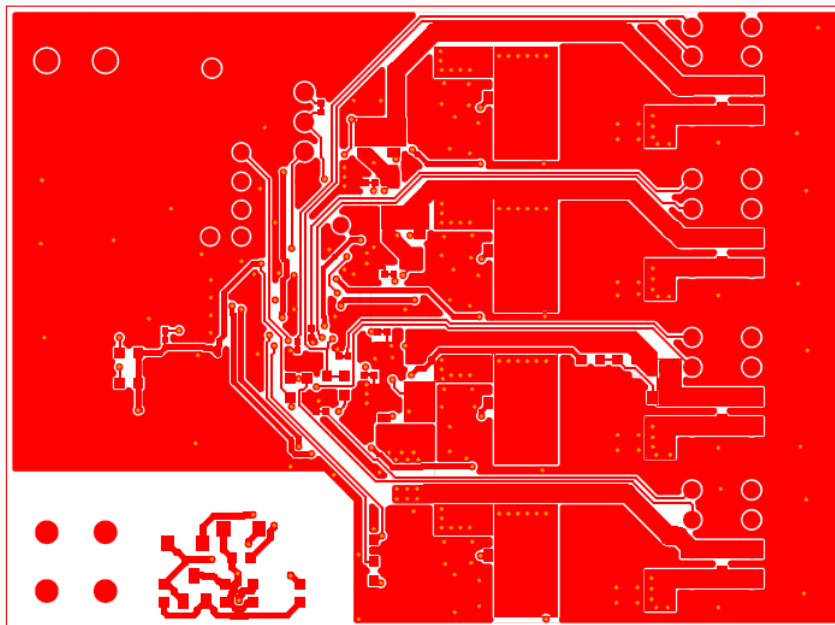

S6SAL211A31-DALI-SA2 Layer 4 (Top view)

5.3 S6SATU03 Component Layout

Figure 5-4 S6SATU03 Component Layout

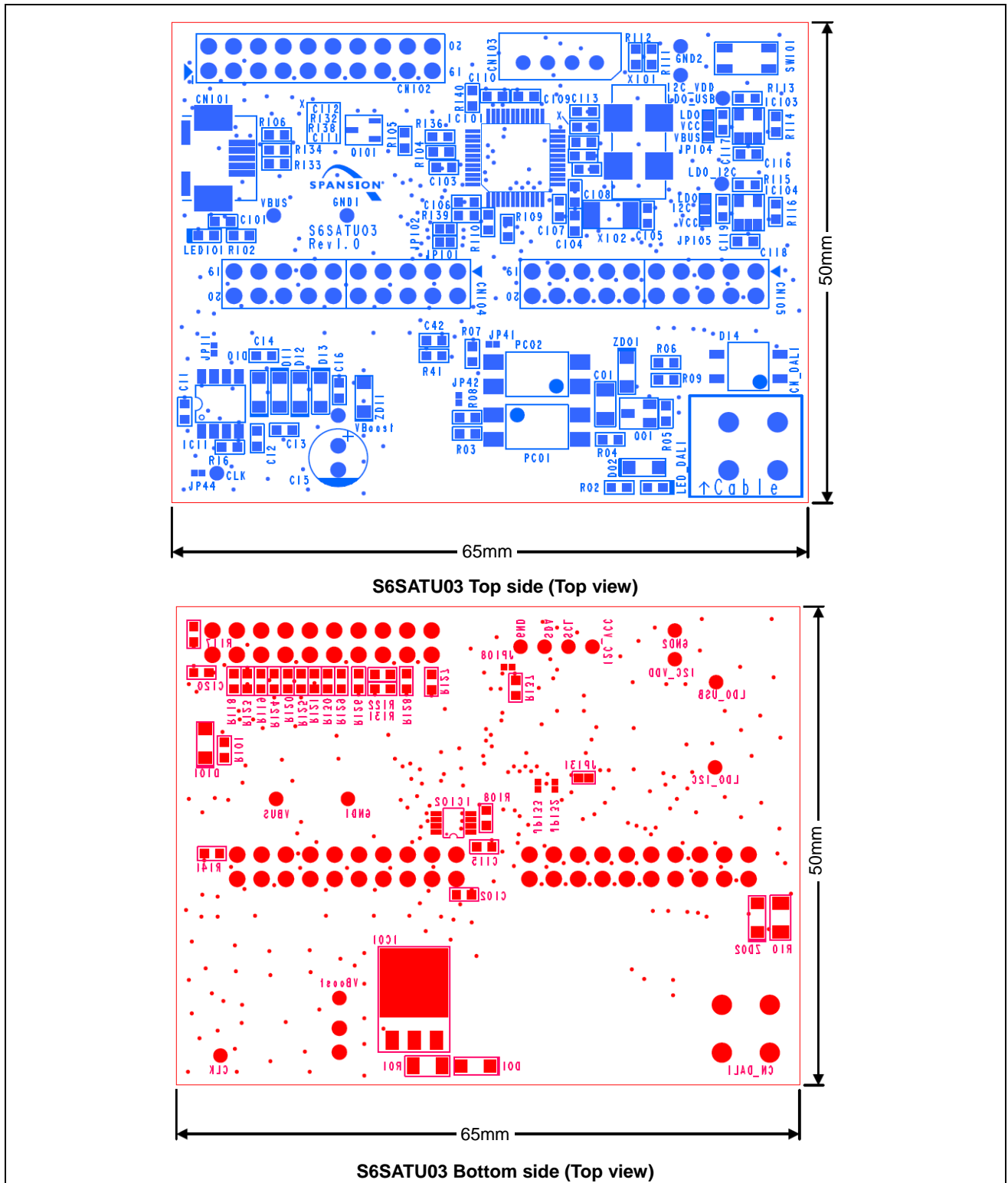

6. Circuit Schematic



6.1 S6SAL211A31-DALI-SA2 Schematic

Figure 6-1 S6SAL211A31-DALI-SA2 Circuit Schematic

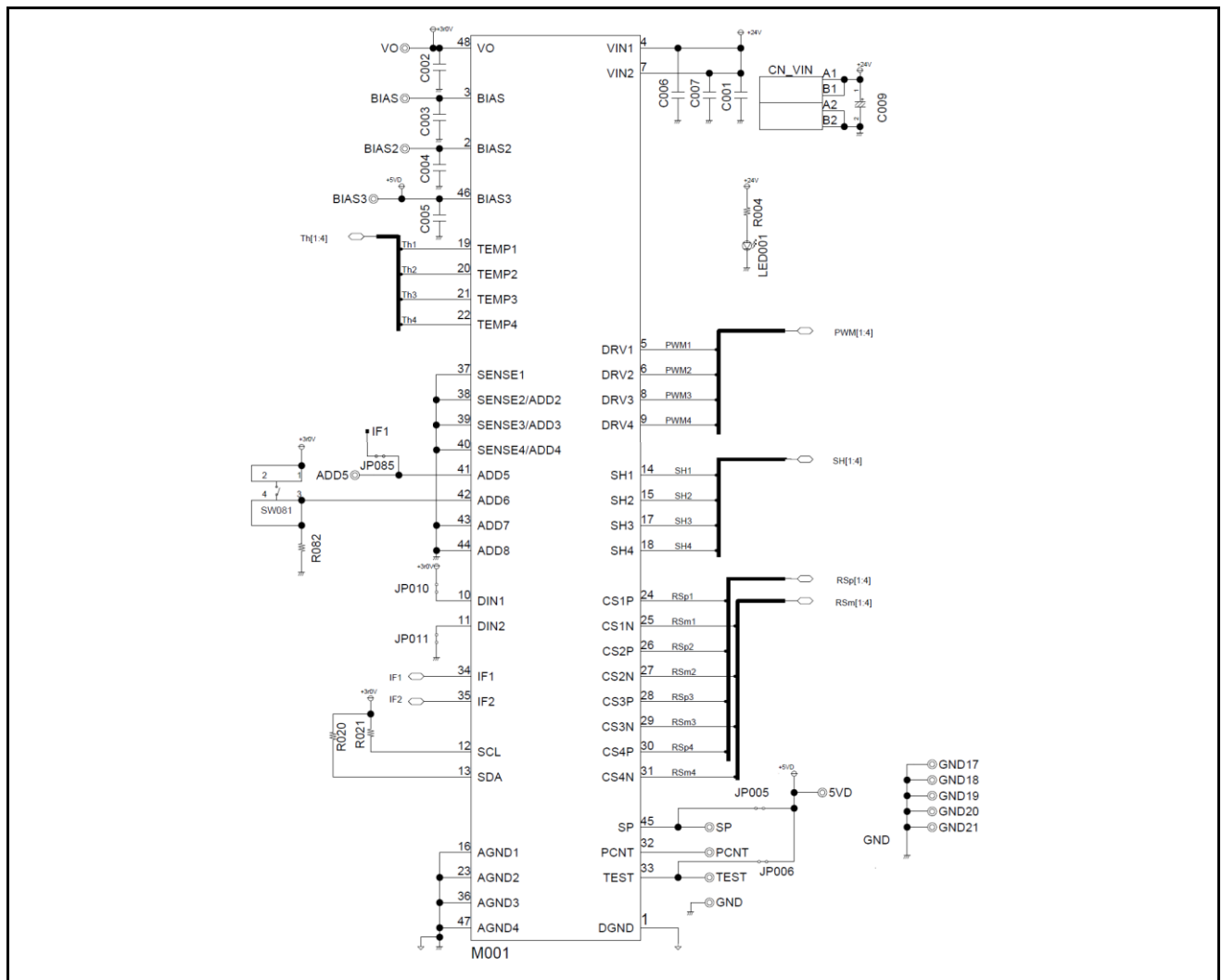

Figure 6-2 S6SAL211A31-DALI-SA2 Circuit Schematic

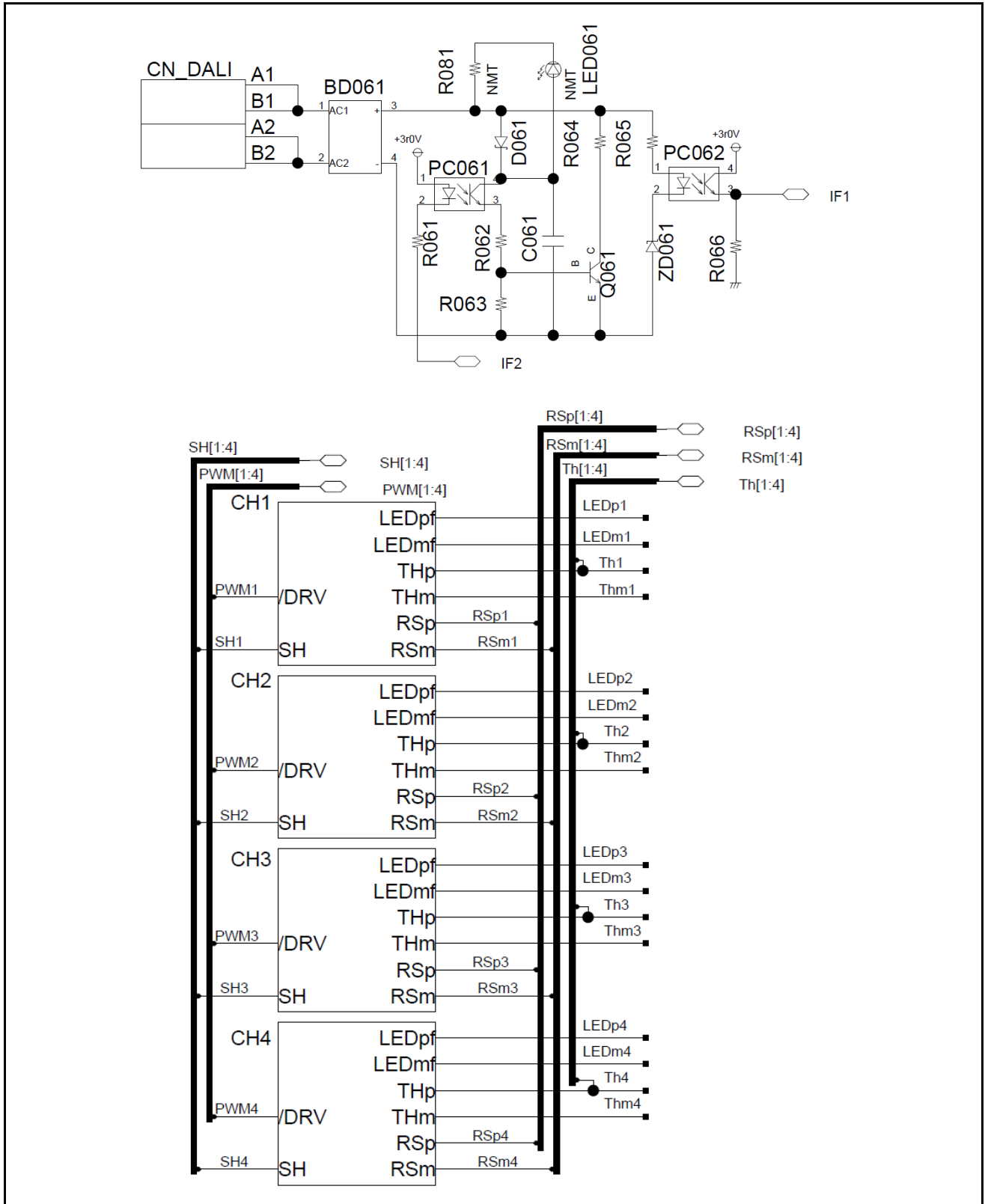

Figure 6-3 S6SAL211A31-DALI-SA2 Circuit Schematic

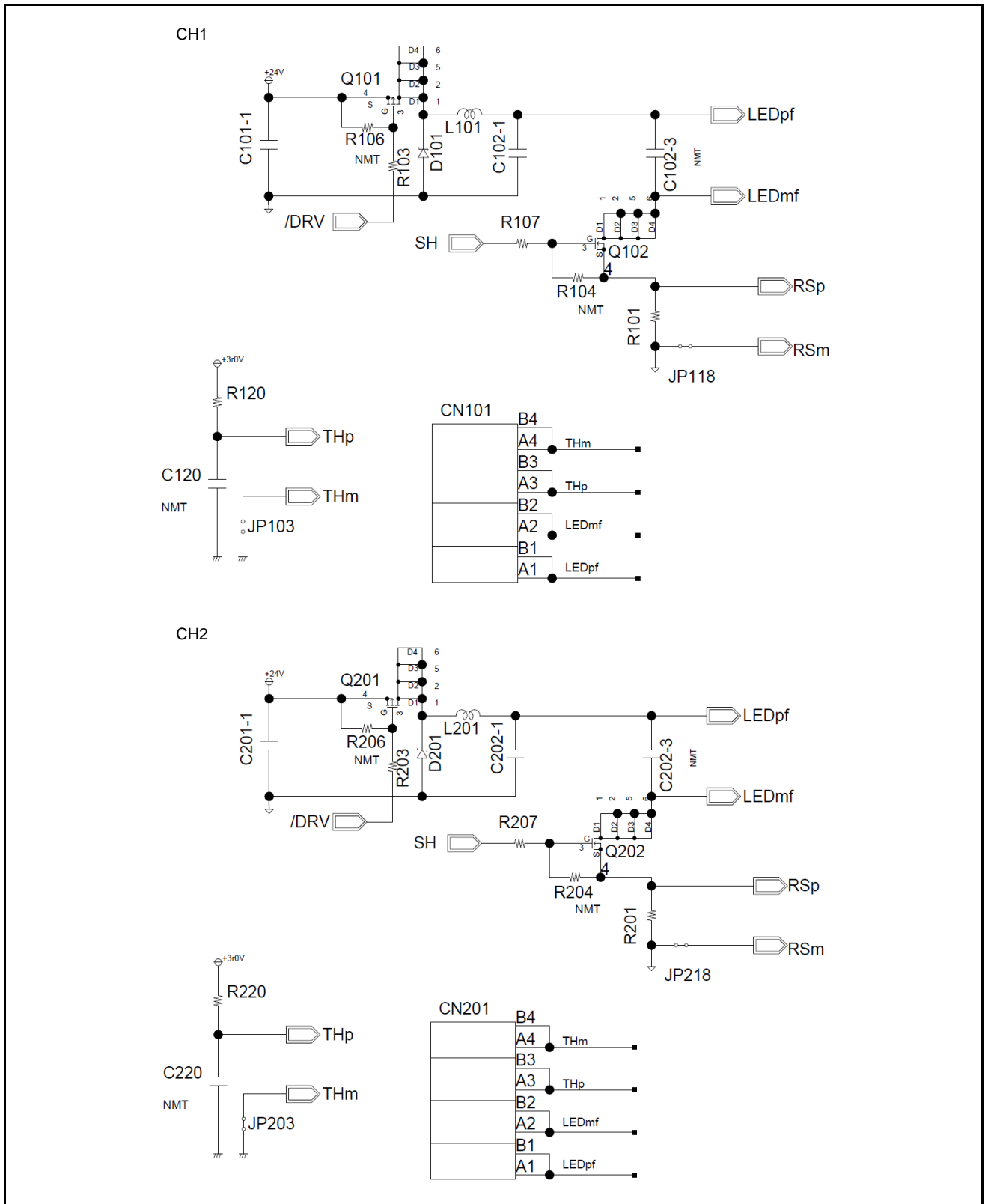
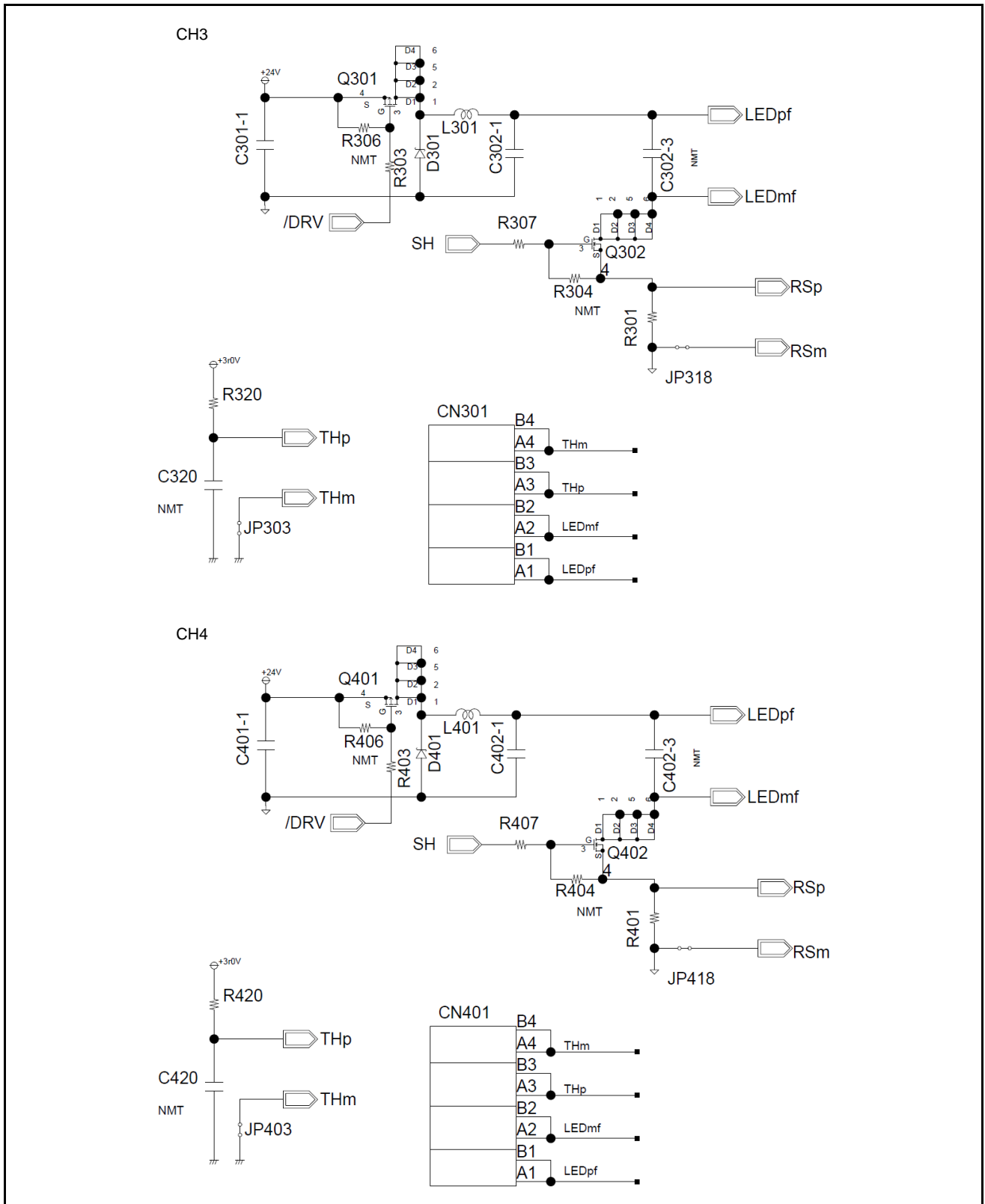
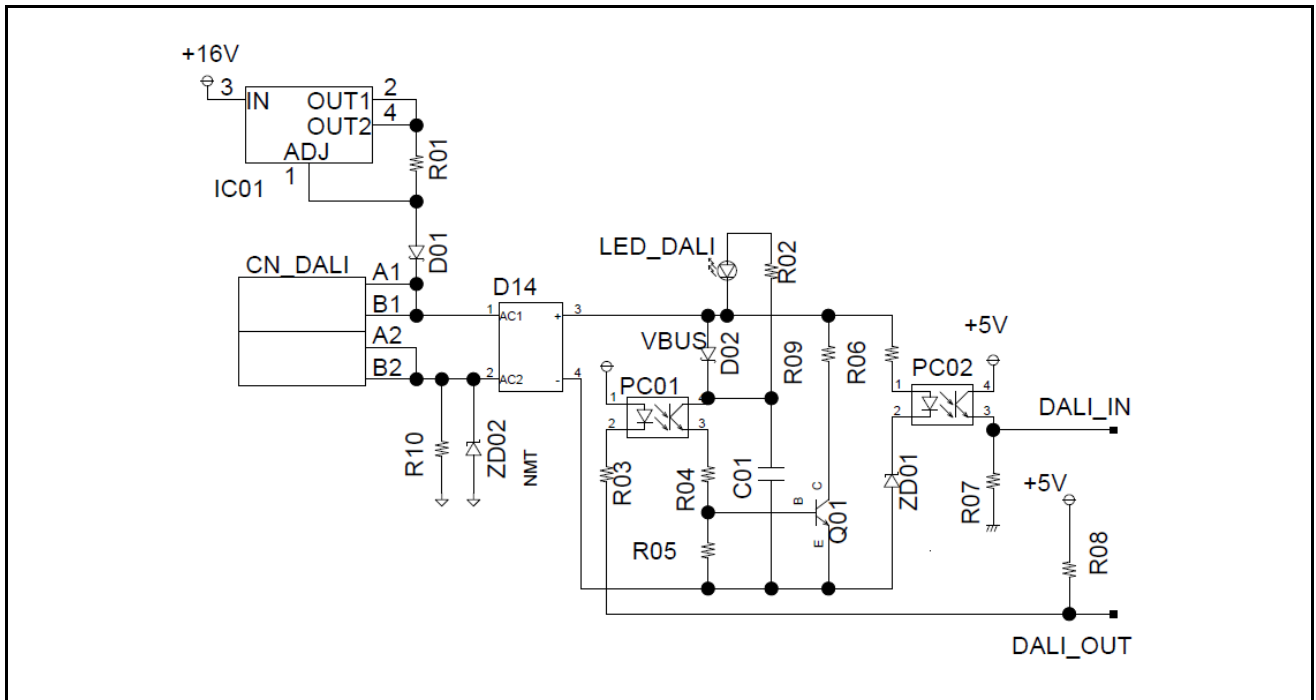

Figure 6-4 S6SAL211A31-DALI-SA2 Circuit Schematic



6.2 S6SATU03 Schematic

Figure 6-5 S6SATU03 DALI Communication Circuit



7. Component List



7.1 S6SAL211A31-DALI-SA2 Components List

Table 7-1 S6SAL211A31-DALI-SA2 Components List

No.	Component	Parts Number	Vendor	Value	Rated Voltage(V)	Rated Current(A)	Remarks
1	BD061	MB2S	FAIRCHILD	-	200	500m	-
2	C001	C2012X5R1V106K125AC	TDK	10 μ F	35	-	-
3	C002	C1608X5R1V475K	TDK	4.7 μ F	35	-	-
4	C003	C1608X5R1H104K080AA	TDK	0.1 μ F	50	-	-
5	C004	C1608X5R1V475K	TDK	4.7 μ F	35	-	-
6	C005	C1608X5R1V475K	TDK	4.7 μ F	35	-	-
7	C006	C1608CH1H101J	TDK	100 pF	50	-	-
8	C007	C1608CH1H101J	TDK	100 pF	50	-	-
9	C009	EKMG350ELL101MF11D	NIPPON-CHEMI-CON	100 μ F	35	-	-
10	C061	C3216X5R1V226M160AC	TDK	22 μ F	35	-	-
11	C101-1	C3216X5R1V475K160AB	TDK	4.7 μ F	35	-	-
12	C102-1	C3225X5R1H106K	TDK	10 μ F	50	-	-
13	C102-3	C1608CH1H102J	TDK	0.001 μ F	50	-	NMT
14	C120	C1608X5R1H104K080AA	TDK	0.1 μ F	50	-	NMT
15	C201-1	C3216X5R1V475K160AB	TDK	4.7 μ F	35	-	-
16	C202-1	C3225X5R1H106K	TDK	10 μ F	50	-	-
17	C202-3	C1608CH1H102J	TDK	0.001 μ F	50	-	NMT
18	C220	C1608X5R1H104K080AA	TDK	0.1 μ F	50	-	NMT
19	C301-1	C3216X5R1V475K160AB	TDK	4.7 μ F	35	-	-
20	C302-1	C3225X5R1H106K	TDK	10 μ F	50	-	-
21	C302-3	C1608CH1H102J	TDK	0.001 μ F	50	-	NMT
22	C320	C1608X5R1H104K080AA	TDK	0.1 μ F	50	-	NMT
23	C401-1	C3216X5R1V475K160AB	TDK	4.7 μ F	35	-	-
24	C402-1	C3225X5R1H106K	TDK	10 μ F	50	-	-
25	C402-3	C1608CH1H102J	TDK	0.001 μ F	50	-	NMT

No.	Component	Parts Number	Vendor	Value	Rated Voltage(V)	Rated Current(A)	Remarks
26	C420	C1608X5R1H104K080AA	TDK	0.1 μ F	50	-	NMT
27	CN101	ML-700-NH-4P	SATOPARTS	-	50	3	-
28	CN201	ML-700-NH-4P	SATOPARTS	-	50	3	-
29	CN301	ML-700-NH-4P	SATOPARTS	-	50	3	-
30	CN401	ML-700-NH-4P	SATOPARTS	-	50	3	-
31	CN_DALI	ML-2100-2P	SATOPARTS	-	300	7	-
32	CN_VIN	ML-2100-2P	SATOPARTS	-	300	7	-
33	D061	MBR140SFT1	ONSEMICONDUCTOR	-	30	500m	-
34	D101	SS23	FAIRCHILD	-	30	2	-
35	D201	SS23	FAIRCHILD	-	30	2	-
36	D301	SS23	FAIRCHILD	-	30	2	-
37	D401	SS23	FAIRCHILD	-	30	2	-
38	L101	SLF12575T-221M1R3	TDK	220 μ H	-	1.3	-
39	L201	SLF12575T-221M1R3	TDK	220 μ H	-	1.3	-
40	L301	SLF12575T-221M1R3	TDK	220 μ H	-	1.3	-
41	L401	SLF12575T-221M1R3	TDK	220 μ H	-	1.3	-
42	LED001	OSHR1608C1A	OptoSupply	-	-	30m	-
43	LED061	OSTG1608C1A	OptoSupply	-	-	30m	NMT
44	M001	S6AL211A	SPANSION	-	-	-	-
45	PC061	PS2561L-1-A	CEL	-	-	-	-
46	PC062	PS2561L-1-A	CEL	-	-	-	-
47	Q061	FMMT491A	DIODES	-	40	1	-
48	Q101	FDC658AP	FAIRCHILD	-	30	4	-
49	Q102	FDC8886	FAIRCHILD	-	30	6.5	-
50	Q201	FDC658AP	FAIRCHILD	-	30	4	-
51	Q202	FDC8886	FAIRCHILD	-	30	6.5	-
52	Q301	FDC658AP	FAIRCHILD	-	30	4	-
53	Q302	FDC8886	FAIRCHILD	-	30	6.5	-
54	Q401	FDC658AP	FAIRCHILD	-	30	4	-
55	Q402	FDC8886	FAIRCHILD	-	30	6.5	-
56	R004	RR0816P-123-D	SSM	12 k Ω	-	-	-
57	R020	RR0816P-103-D	SSM	10 k Ω	-	-	-
58	R021	RR0816P-103-D	SSM	10 k Ω	-	-	-
59	R061	RR0816P-681-D	SSM	680 Ω	-	-	-
60	R062	RR0816P-331-D	SSM	330 Ω	-	-	-
61	R063	RR0816P-332-D	SSM	3.3 k Ω	-	-	-
62	R064	RK73H1JTDD4R70F	KOA	4.7 Ω	-	-	-
63	R065	RR0816P-103-D	SSM	10 k Ω	-	-	-
64	R066	RR0816P-562-D	SSM	5.6 k Ω	-	-	-
65	R081	RR0816P-103-D	SSM	10 k Ω	-	-	NMT
66	R082	RR0816P-104-D	SSM	100 k Ω	-	-	-
67	R101	RL1632R-R200-F	SSM	200 m Ω	-	-	-

No.	Component	Parts Number	Vendor	Value	Rated Voltage(V)	Rated Current(A)	Remarks
68	R103	RK73Z1J	KOA	0Ω	-	1	-
69	R104	RK73H1JTDD1004F	KOA	1 MΩ	-	-	NMT
70	R106	RK73H1JTDD1004F	KOA	1 MΩ	-	-	NMT
71	R107	RK73Z1J	KOA	0Ω	-	1	-
72	R120	RR0816P-752-D	SSM	7.5 kΩ	-	-	-
73	R201	RL1632R-R200-F	SSM	200 mΩ	-	-	-
74	R203	RK73Z1J	KOA	0Ω	-	1	-
75	R204	RK73H1JTDD1004F	KOA	1 MΩ	-	-	NMT
76	R206	RK73H1JTDD1004F	KOA	1 MΩ	-	-	NMT
77	R207	RK73Z1J	KOA	0Ω	-	1	-
78	R220	RR0816P-752-D	SSM	7.5 kΩ	-	-	-
79	R301	RL1632R-R200-F	SSM	200 mΩ	-	-	-
80	R303	RK73Z1J	KOA	0Ω	-	1	-
81	R304	RK73H1JTDD1004F	KOA	1 MΩ	-	-	NMT
82	R306	RK73H1JTDD1004F	KOA	1 MΩ	-	-	NMT
83	R307	RK73Z1J	KOA	0Ω	-	1	-
84	R320	RR0816P-752-D	SSM	7.5 kΩ	-	-	-
85	R401	RL1632R-R200-F	SSM	200 mΩ	-	-	-
86	R403	RK73Z1J	KOA	0Ω	-	1	-
87	R404	RK73H1JTDD1004F	KOA	1 MΩ	-	-	NMT
88	R406	RK73H1JTDD1004F	KOA	1 MΩ	-	-	NMT
89	R407	RK73Z1J	KOA	0Ω	-	1	-
90	R420	RR0816P-752-D	SSM	7.5 kΩ	-	-	-
91	SW081	SKRSPACE010	ALPS	-	-	50m	-
92	ZD061	MMSZ5229B	FAIRCHILD	-	-	-	-

NMT: No mount.

These components are compliant with RoHS, and please ask each vendor for details if necessary.

7.2 S6SATU03 Components List

Table 7-2 S6SATU03 DALI Communication Components List

No	Component	Parts Number	Vendor	Value	Rated Voltage(V)	Rated Current(A)	Remarks
1	C01	C3216X5R1V226M160AC	TDK	22 μ F	35	-	-
2	D01	MBR140SFT1	ONSEMICONDUCTOR	-	30	500m	-
3	D02	MBR140SFT1	ONSEMICONDUCTOR	-	30	500m	-
4	D14	MB2S	FAIRCHILD	-	200	500m	-
5	IC01	NJM317DL1	NJR	-	40	400m	-
6	LED_DALI	OSYG1608C1A	OptoSupply	-	-	30m	-
7	R01	RK73H2BTDD24R0F	KOA	24 Ω	-	-	-
8	R02	RR0816P-153-D	SSM	15 k Ω	-	-	-
9	R03	RR0816P-681-D	SSM	680 Ω	-	-	-
10	R04	RR0816P-331-D	SSM	330 Ω	-	-	-
11	R05	RR0816P-332-D	SSM	3.3 k Ω	-	-	-
12	R06	RR0816P-562-D	SSM	5.6 k Ω	-	-	-
13	R07	RR0816P-562-D	SSM	5.6 k Ω	-	-	-
14	R08	RR0816P-103-D	SSM	10 k Ω	-	-	-
15	R09	RK73H1JTDD4R70F	KOA	4.7 Ω	-	-	-
16	R10	RK73H2BTDD10R0F	KOA	10 Ω	-	-	-
17	PC01	PS2561L-1-A	CEL	-	-	-	-
18	PC02	PS2561L-1-A	CEL	-	-	-	-
19	Q01	FMMT491A	DIODES	-	40	1	-
20	ZD01	MMSZ5229B	FAIRCHILD	4.3	-	-	-
21	ZD02	MMSZ5229B	FAIRCHILD	-	-	-	NMT
22	CN_DALI	ML-2100-2P	SATOPARTS	-	300	7	-

NMT: No mount.

These components are compliant with RoHS, and please ask each vendor for details if necessary.

8. S6SAL211A31-DALI-SA2 Property Data



Figure 8-1 Switching Waveform

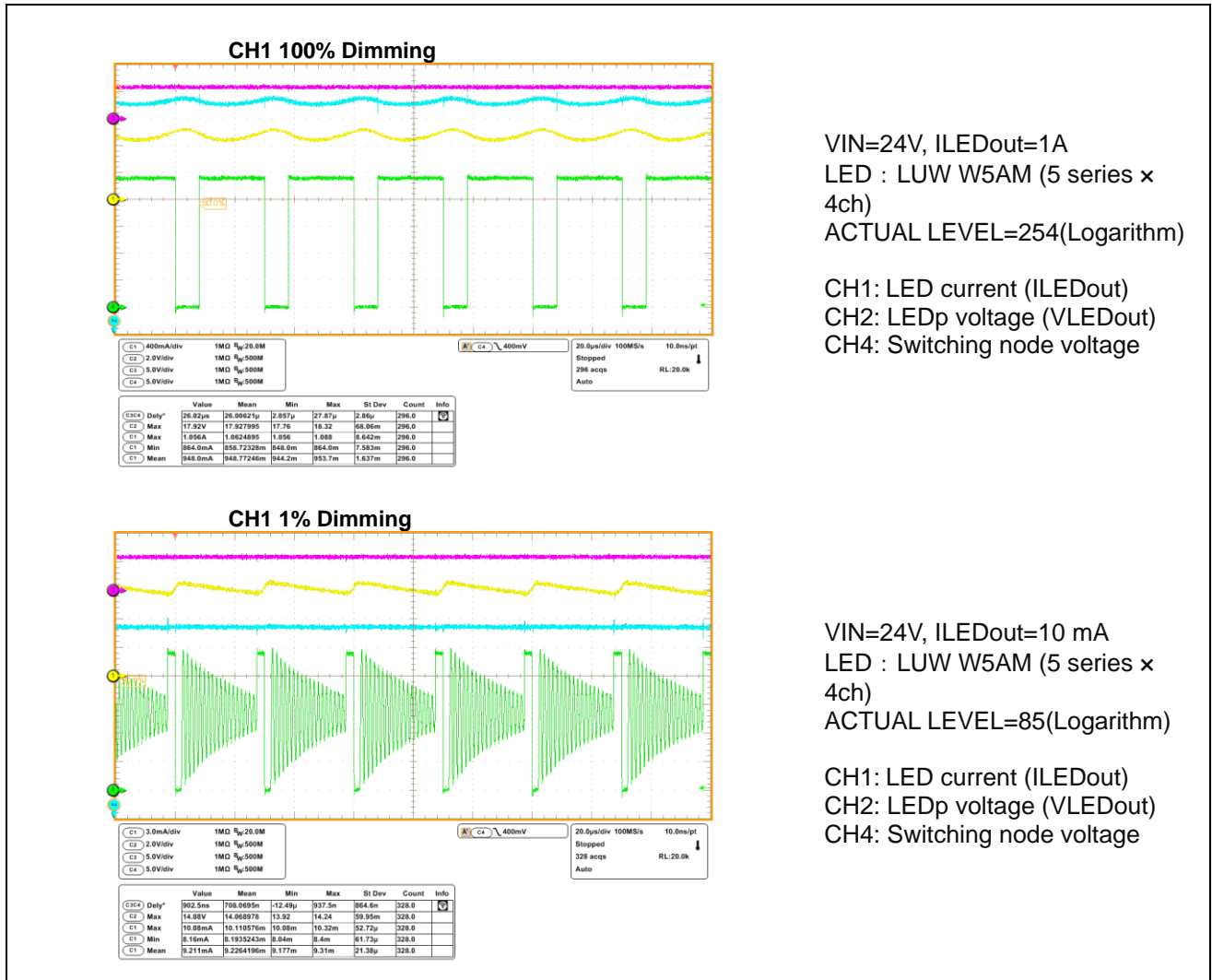

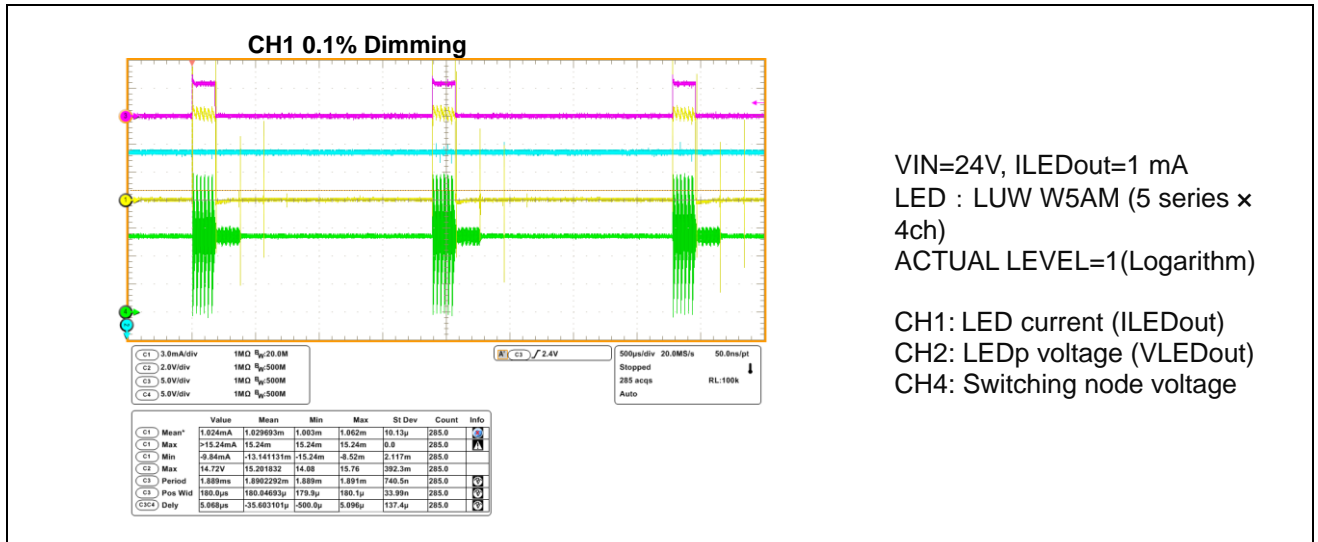

9. Board Picture

9.1 S6SAL211A31-DALI-SA2 Board Picture

Figure 9-1 S6SAL211A31-DALI-SA2 Board Picture

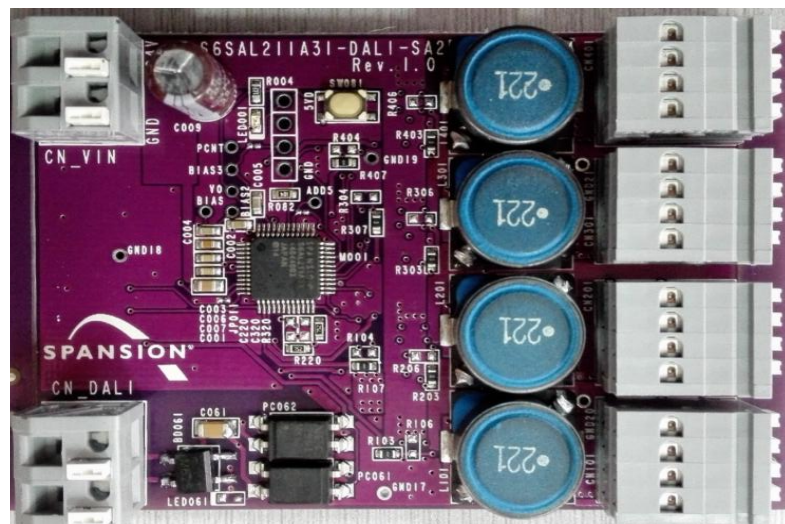

S6SAL211A31-DALI-SA2 (Top View)

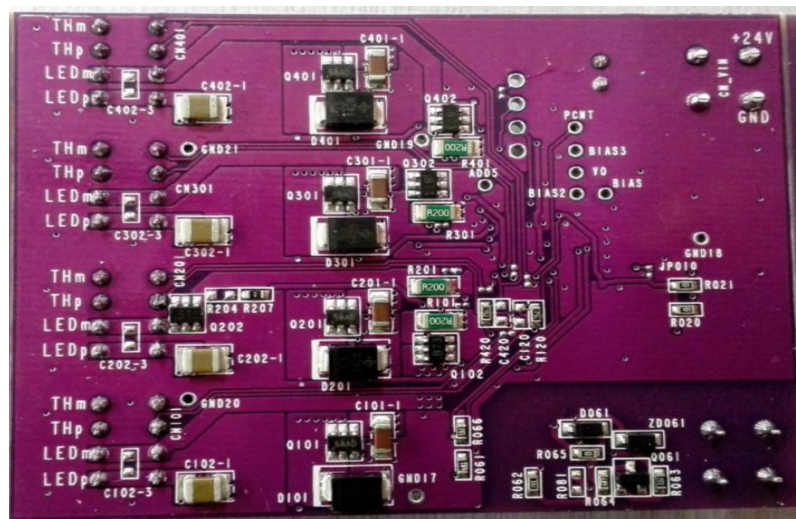

S6SAL211A31-DALI-SA2 (Bottom View)

9.2 S6SATU03 Board Picture

Figure 9-2 S6SATU03 Board Picture

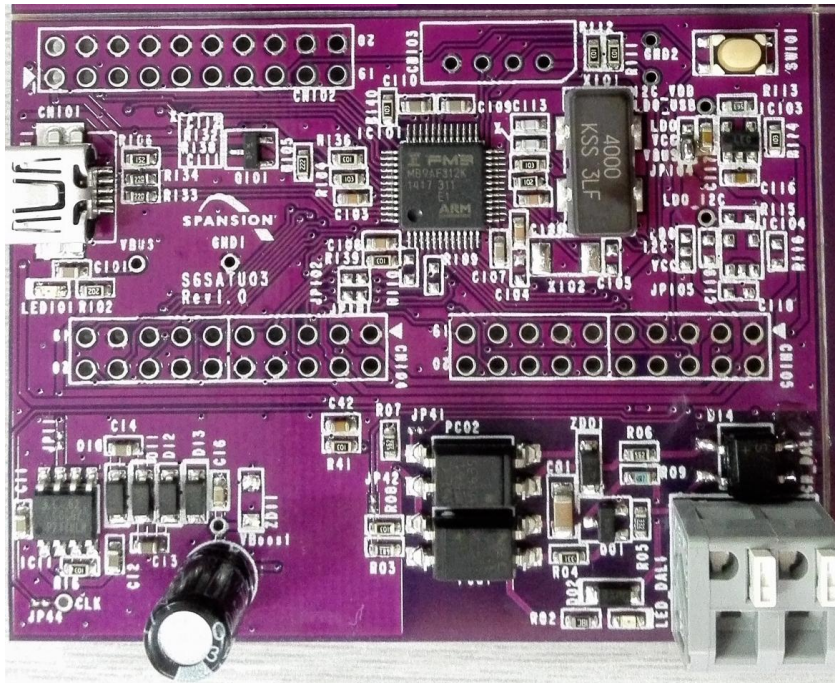

S6SATU03 (Top View)

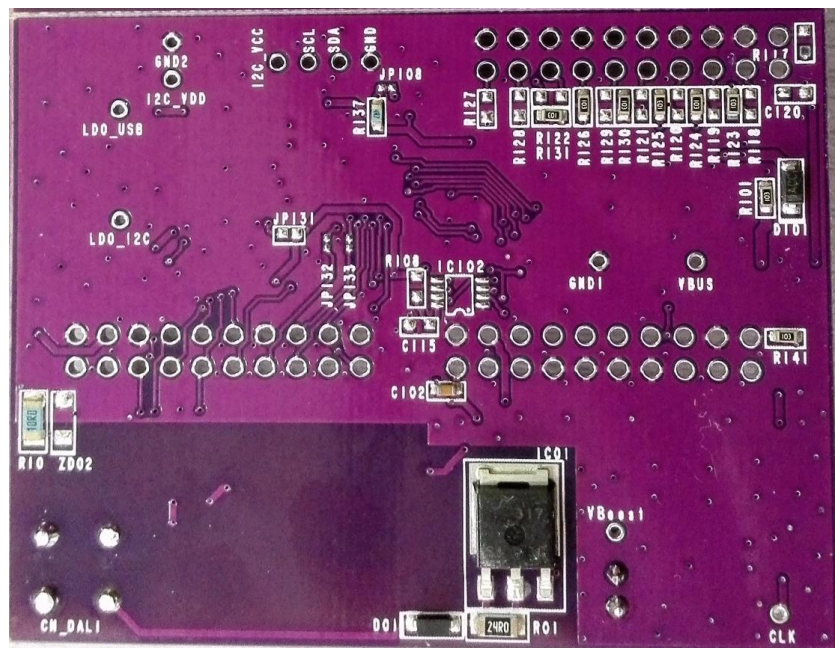

S6SATU03 (Bottom View)

10. Ordering Information



Table 10-1 Ordering Information

Part Number	EVB Revision	Note
S6SAL211A31SA3001	S6SAL211A31-DALI-SA2 Rev1.0 S6SATU03 Rev1.0	-
S6SAL211A31SA2001	S6SAL211A31-DALI-SA2 Rev1.0	-

Revision History



Document Revision History

Document Title: S6SAL211A31SA2001, S6SAL211A31SA3001 4ch 72W LED Driver and Communication Board Operation Guide Document Number: 002-08632			
Revision	Issue Date	Origin of Change	Description of Change
**	03/31/2015	HSAT	Initial release
*A	04/26/2016	HSAT	Migrated Spansion Guide from S6SAL211A31SA3001_SS405-00003-1v0-E to Cypress format