

REV	COMMENT	DATE	DRAWN BY
1.00	Release	12/19/2014	R.Romes
2.00	Release	05/12/2015	R.Romes

**RENEASAS** Electronics Europe GmbH

Title: **ADAS-SK (R-CAR-H2)**

DU (VCC3/LVDS), SD, USB...

Size: **A2** Document Number: **E5S-0400-102-02**

Date: Fri May 22 11:38:07 2015 PAGE 1 OF 5 |V2.00

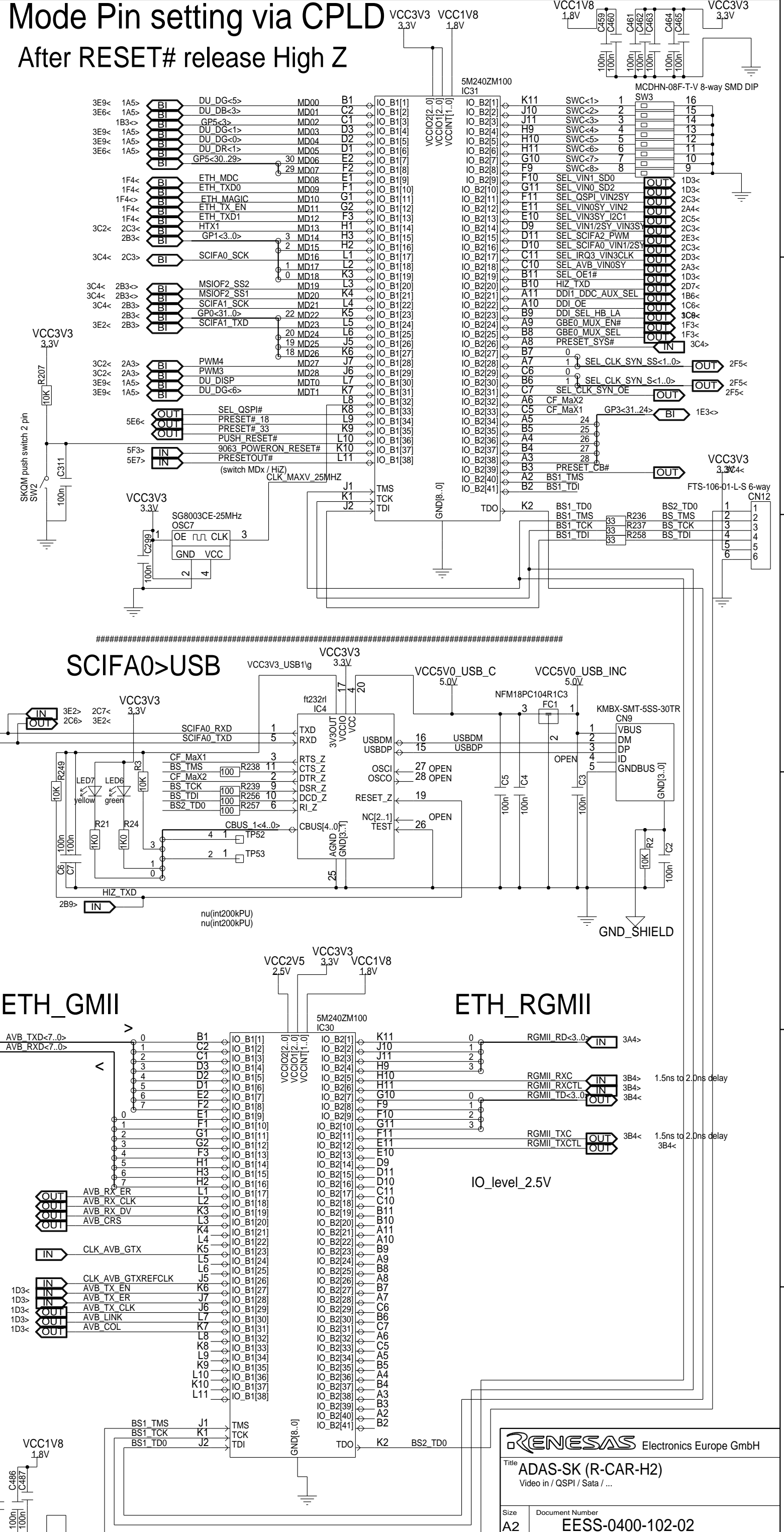
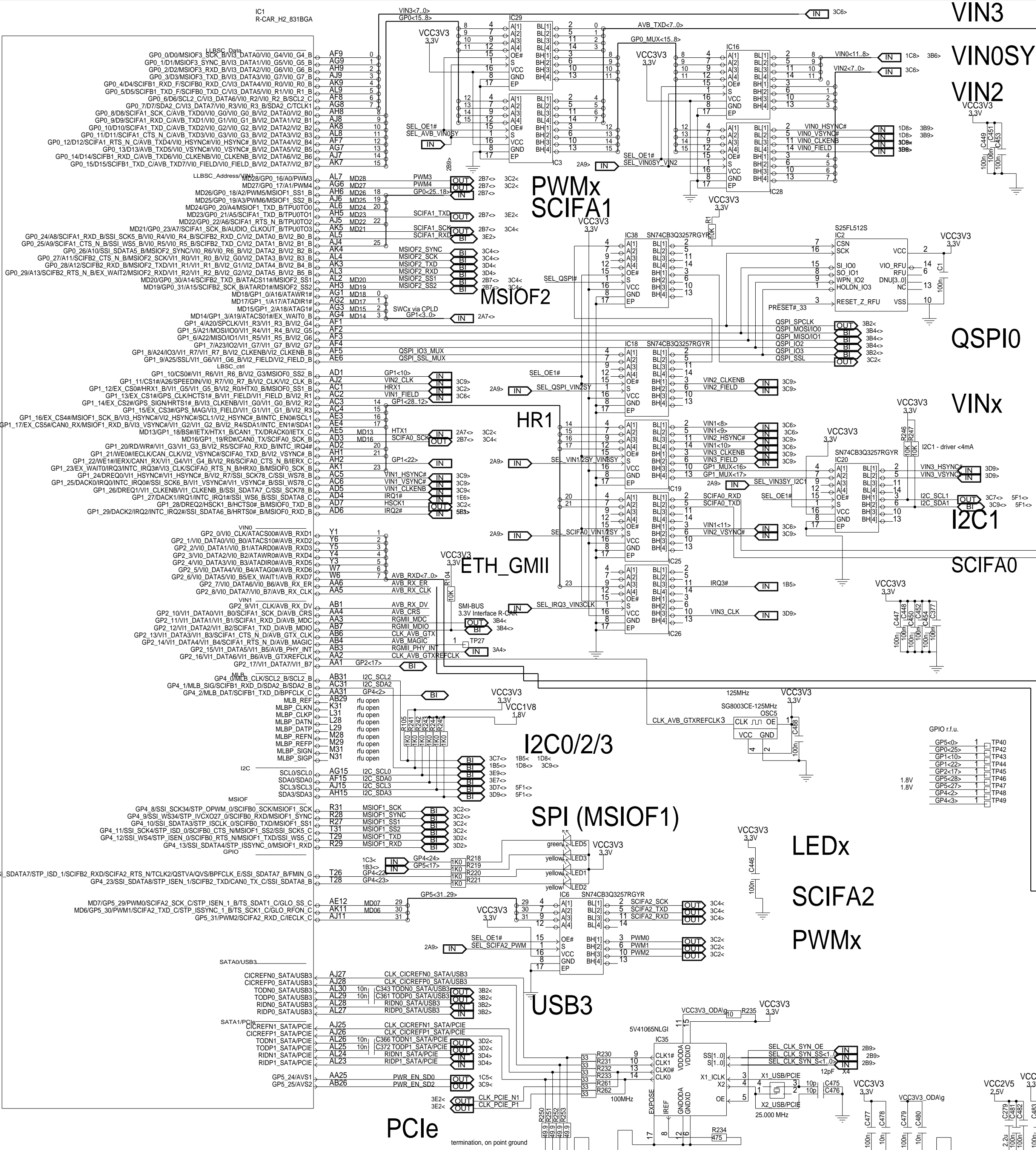

# Module Interface 440Pin connector / bottom side

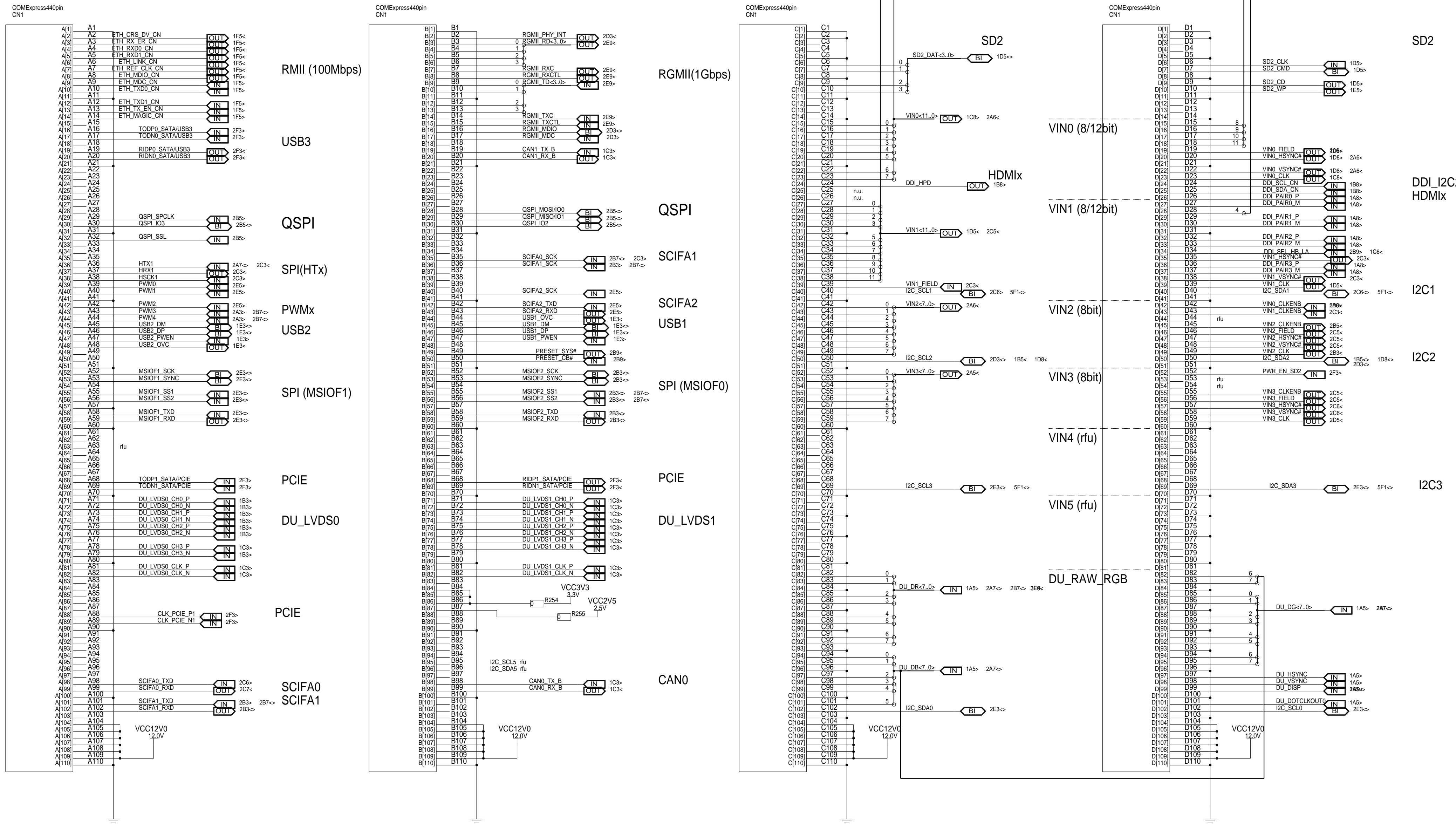

# 2ch - 32bit / 4x16bit DDR3-1600

## 4Gbit x4 == 2GByte

### DDR3-CHA

R-CAR\_H2\_831BGA

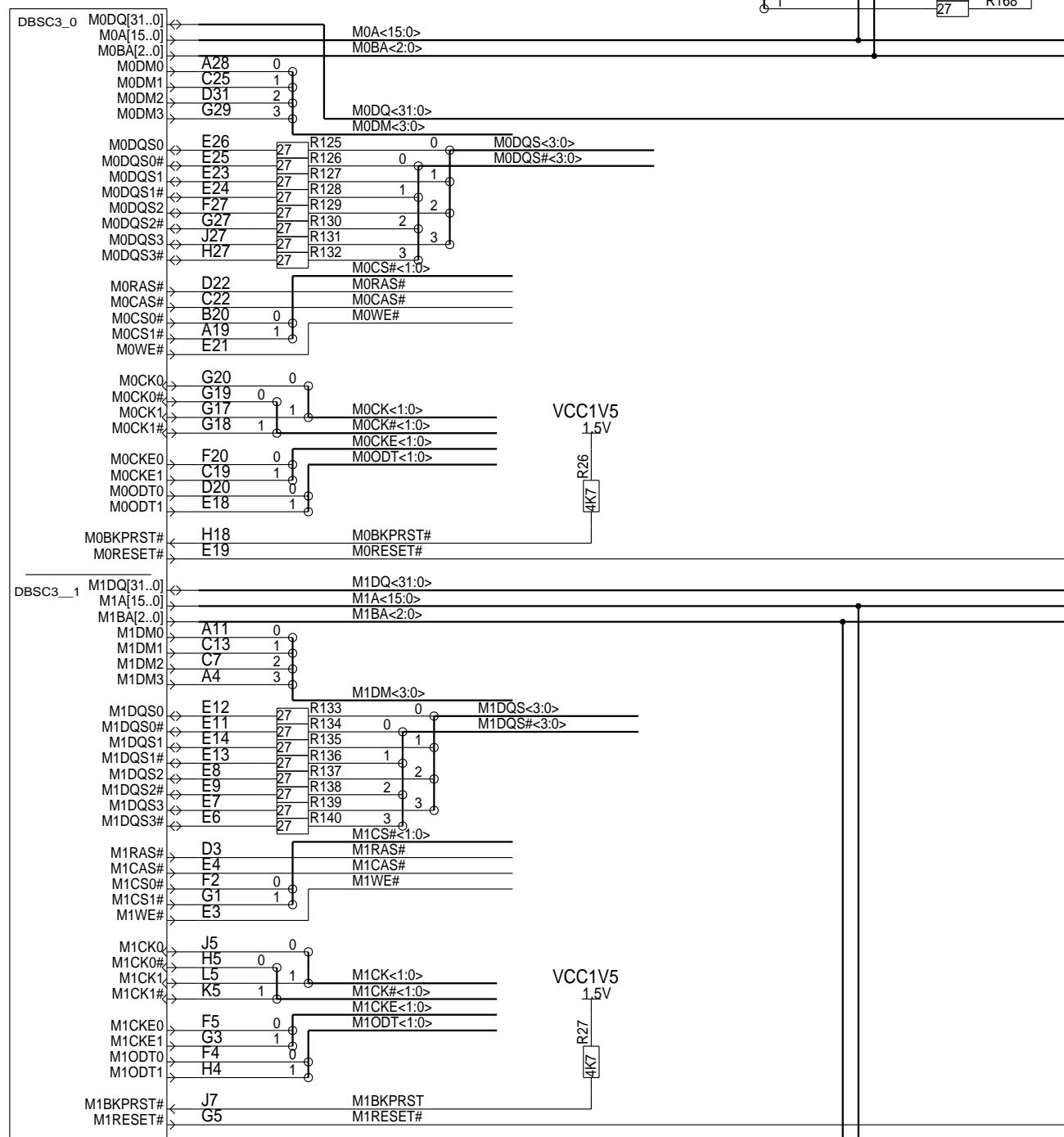

### DDR3-CHB

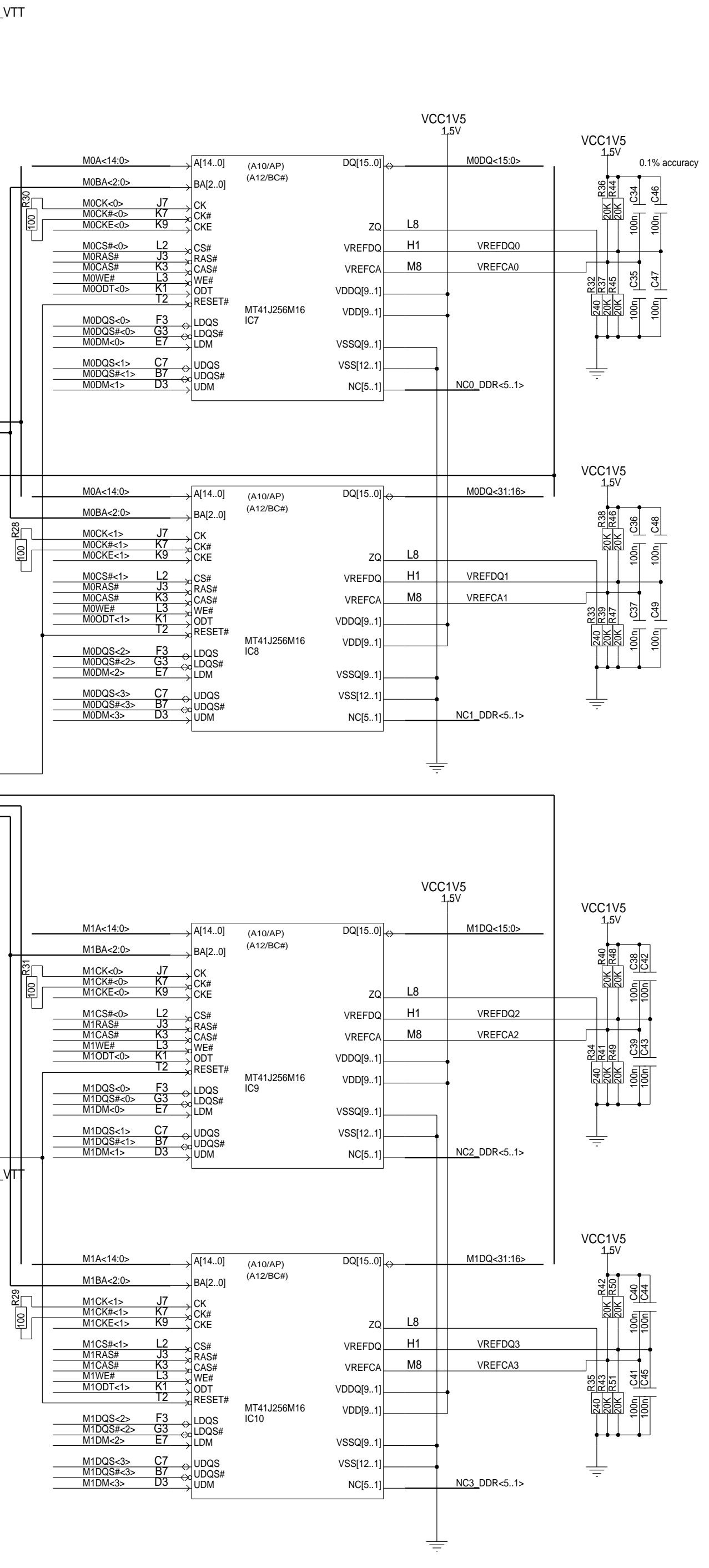
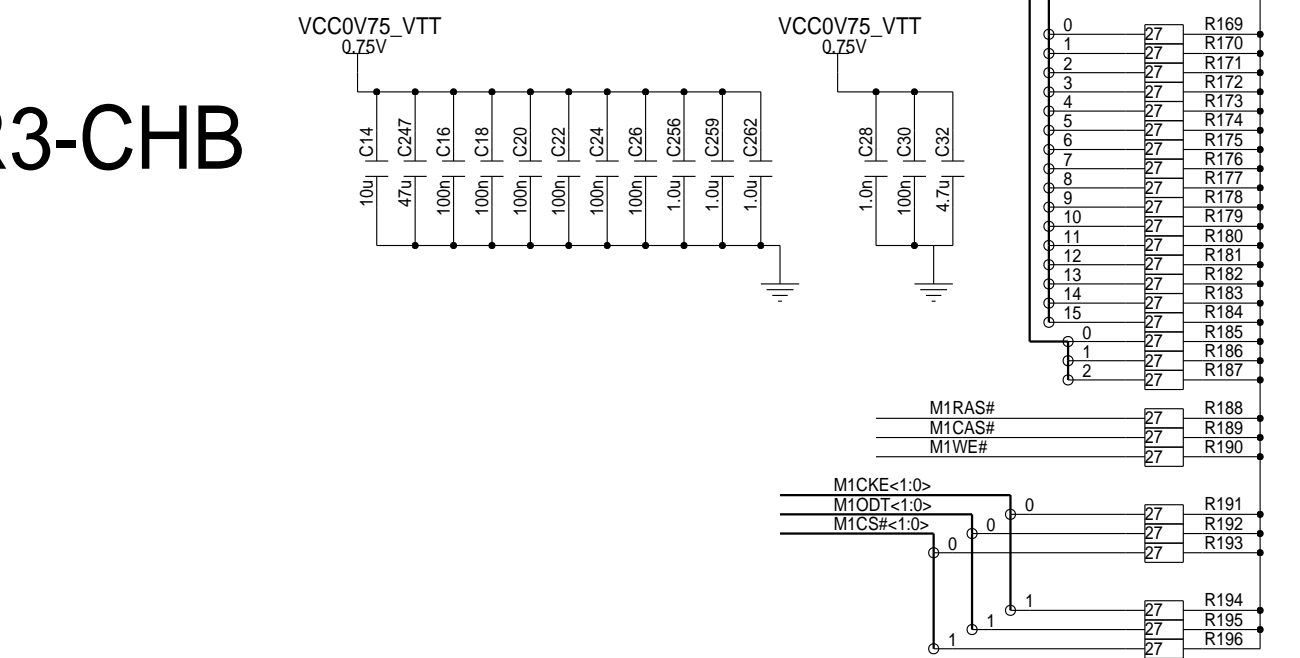

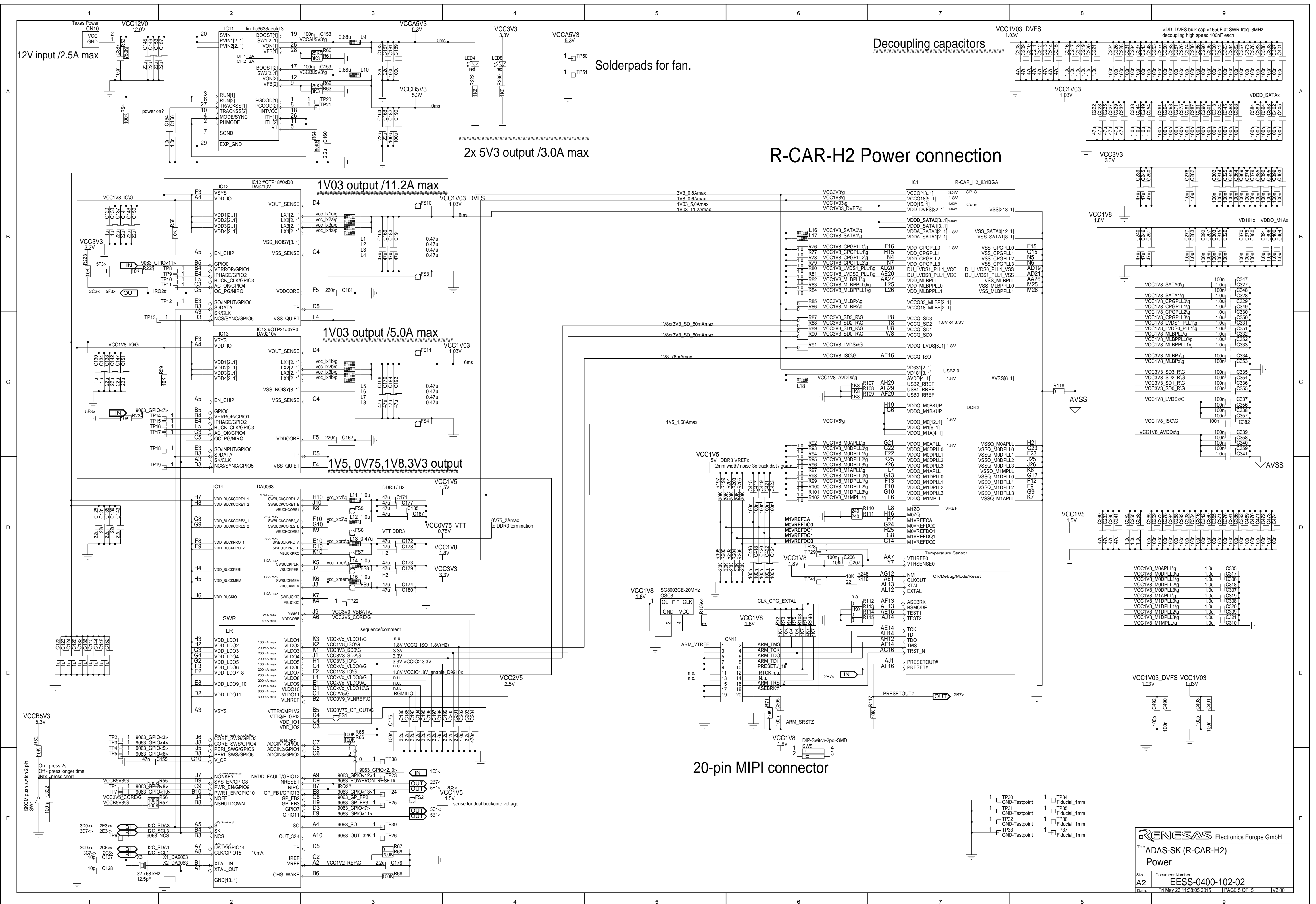

Decoupling capacitors

Solderpads for fan.

### R-CAR-H2 Power connection

12V input /2.5A max

2x 5V3 output /3.0A max

1V03 output /11.2A max

1V03 output /5.0A max

1V5, 0V75, 1V8, 3V3 output

20-pin MIPI connector

**RENESAS** Electronics Europe GmbH  
 The ADAS-SK (R-CAR-H2)  
 Power  
 Size Document Number  
 A2 EESS-0400-102-02  
 Date: Fri May 22 11:38:05 2015 PAGE 5 OF 5 V2.00