

Eval-M1-1302

For iMOTION™ Modular Application Design Kit

About this document

Scope and purpose

The purpose of this document is to provide a comprehensive description of functionalities and guide for the usage of the Eval-M1-1302 board which acts as the controller unit in a motor drive system. This document describes the features and hardware details of the Eval-M1-1302 board.

Environmental conditions were considered in the design of the evaluation board. The design was tested as described in this document but not qualified regarding safety requirements or manufacturing and operation over the whole operating temperature range or lifetime. The boards provided by Infineon are subject to functional testing only.

Evaluation boards are not subject to the same procedures as regular products regarding Returned Material Analysis (RMA), Process Change Notification (PCN) and Product Discontinuation (PD). Evaluation boards are intended to be used under laboratory conditions by specialists only.

Intended audience

This document is for anyone interested in exploring the motor control capabilities of the XMC1302 device.

Table of Contents

About this document	1
Table of Contents	1
Introduction	2
1 Overview	2
1.1 Key Features.....	2
1.2 Block Diagram.....	3
2 Hardware Description	4
2.1 Power Supply	4
2.2 Clock Generation	6
2.3 Debug Interface.....	6
2.3.1 On-board USB debugger	6
2.3.2 8-pin Debug Connector.....	7
2.3.3 16-pin Debug Connector.....	7
2.4 USIC Connector	8
2.5 Hall Sensor and Encoder Connectors.....	9
2.6 Power Board Connector	10
3 Production Data	11
3.1 Schematics	11
3.2 Component Placement and PCB layout	16
3.3 Bill of Material (BOM)	17
Revision History	19

Introduction

This document describes the features and hardware details of the Eval-M1-1302 designed to work with iMotion™ MADK boards.

1 Overview

The Eval_M1-1302 board houses the XMC1302 Microcontroller from Infineon Technologies, a power board connector, an interface for bipolar latching Hall-effect position sensors, an encoder sensor interface connector, a USIC interface and an isolated on-board debug interface. The board along with a three phase inverter demonstrates the capabilities of the XMC1302 in motor control application. The main use case for this board is to demonstrate the motor control features of the XMC1302. The focus is safe operation under evaluation conditions.

1.1 Key Features

The key features of the Eval-M1-1302 board are:

- Infineon XMC1302 Microcontroller which is an ARM® Cortex™-M0-based device with 200 kByte on-chip flash memory inside a TSSOP38 package
- Connection to power section via the power board connector
- Combined hall sensor and encoder interface
- USIC interface connector for connection of UART, SPI or I²C
- 6 LEDs
 - 2 Power indicating LEDs
 - 1 User LED
 - 1 Encoder enable LED
 - 2 Debug LEDs (DEBUG, COM)
- Isolated Debug options
 - SEGGER J-Link LITE on-board debugger via USB connector
 - 16-pin debug connector supporting the Infineon DriveMonitor USB Stick V2
- Isolated Connectivity
 - UART channel of SEGGER J-Link LITE on-board debugger via USB connector
- Power supply of the MCU domain, providing 3.3 V and 5 V via connector J3
- Power supply of the isolated debug domain
 - Via debug USB connector
 - Via 16-pin connector which interfaces with the DriveMonitor USB Stick V2

Overview

1.2 Block Diagram

The functional block diagram of the Eval-M1-1302 can be found in Figure 1. The building blocks of Eval_M1-1302 board are:

- Power Board connector
- HALL interface connector for position sensing
- Encoder interface connector
- Encoder Enable signals via GPIO
- One user LED connected to GPIO
- USIC0 interface connector
- Isolated on-board debugger via Debug Micro-USB connector with UART
- 16-pin debug connector for the Drive Monitor USB Stick V2

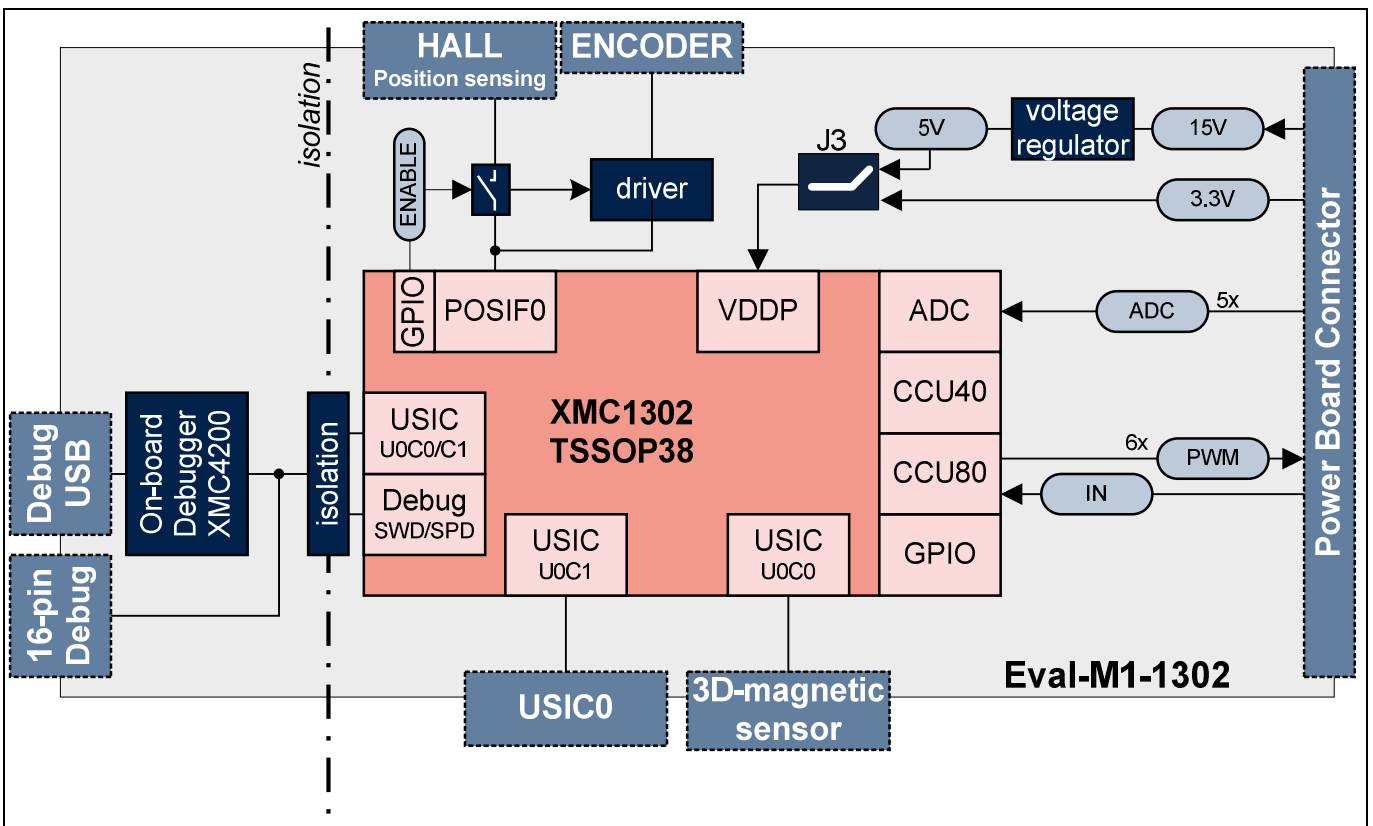

Figure 1 Block Diagram of the Eval-M1-1302

Hardware Description

2 Hardware Description

This section gives a detailed description of the hardware and how it can be used, Figure 2 depicts an overview of the Eval-M1-1302 board.

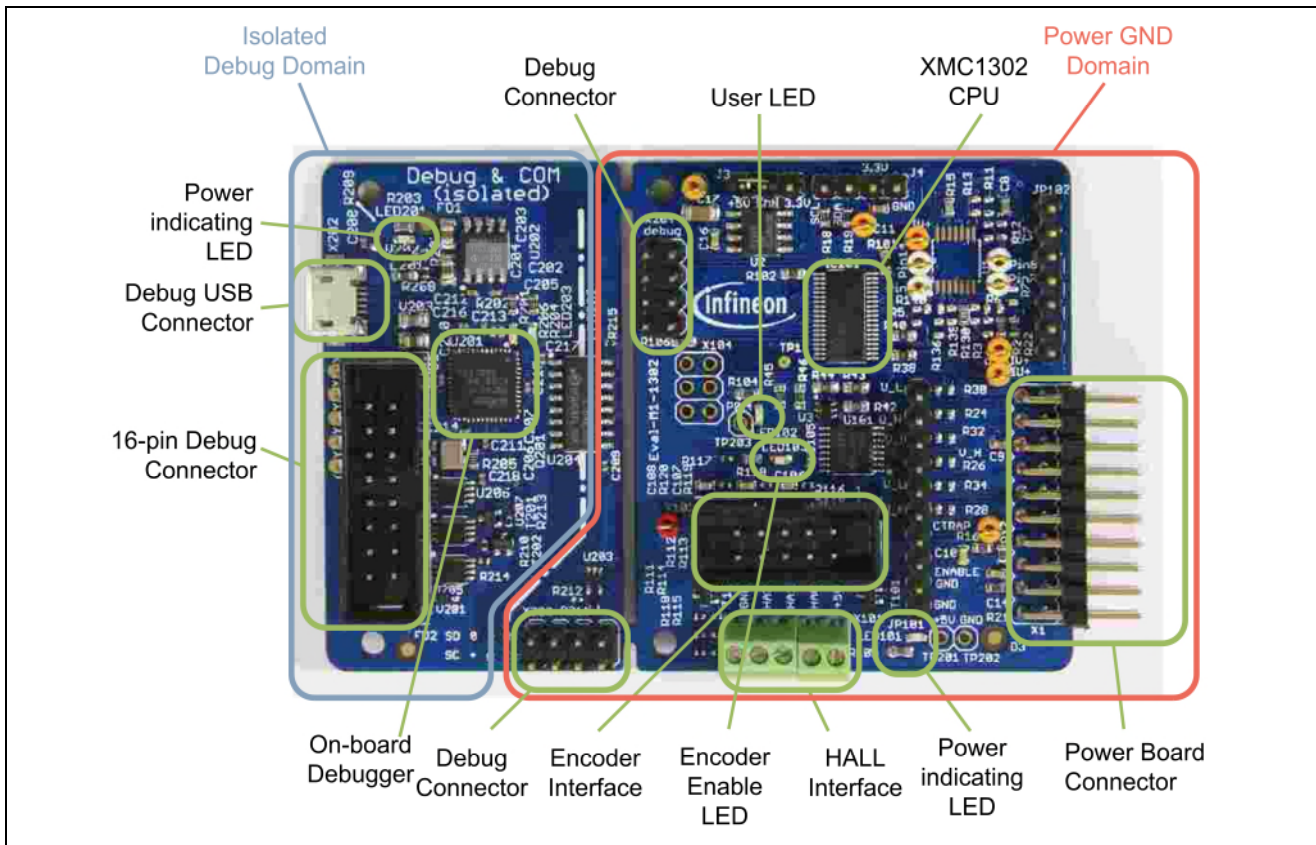

Figure 2 Overview of Eval-M1-1302

2.1 Power Supply

The Eval-M1-1302 is designed with two galvanically isolated supply domains as outlined in Figure 2. On the left side, there is the debug domain, which contains a XMC4200 MCU as on-board debug controller (OBD) as well as level shifters to a 5V debug interface like the Drive Monitor USB Stick V2. The debug domain can be powered via the USB plug as well as via the 16-pin Debug connector.

On the right side there is the power GND supply domain, which connects to the power supply of the XMC1302 MCU and the peripheral components. This supply domain is usually powered from the power board which will be connected to the Eval-M1-1302 board via the connector. The typical current drawn by the Eval-M1-1302 board at the power GND domain is about 25 mA. To indicate the power status of the Eval-M1-1302, two power indicating LEDs are provided on board as shown in Figure 3. The LED will be ON when the corresponding power rail is powered. This power status indication is described in Table 1.

Table 1 Power status LED's

LED Reference	Power Rail	Voltage	Note
LED101	VDD	3.3 V/5 V	Power GND domain, must always be ON
LED201	VISO5	5 V	Debug supply domain, ON if debug domain is intended to be used.

Hardware Description

Figure 3 and Figure 4 illustrate the power supply concept of the control card.

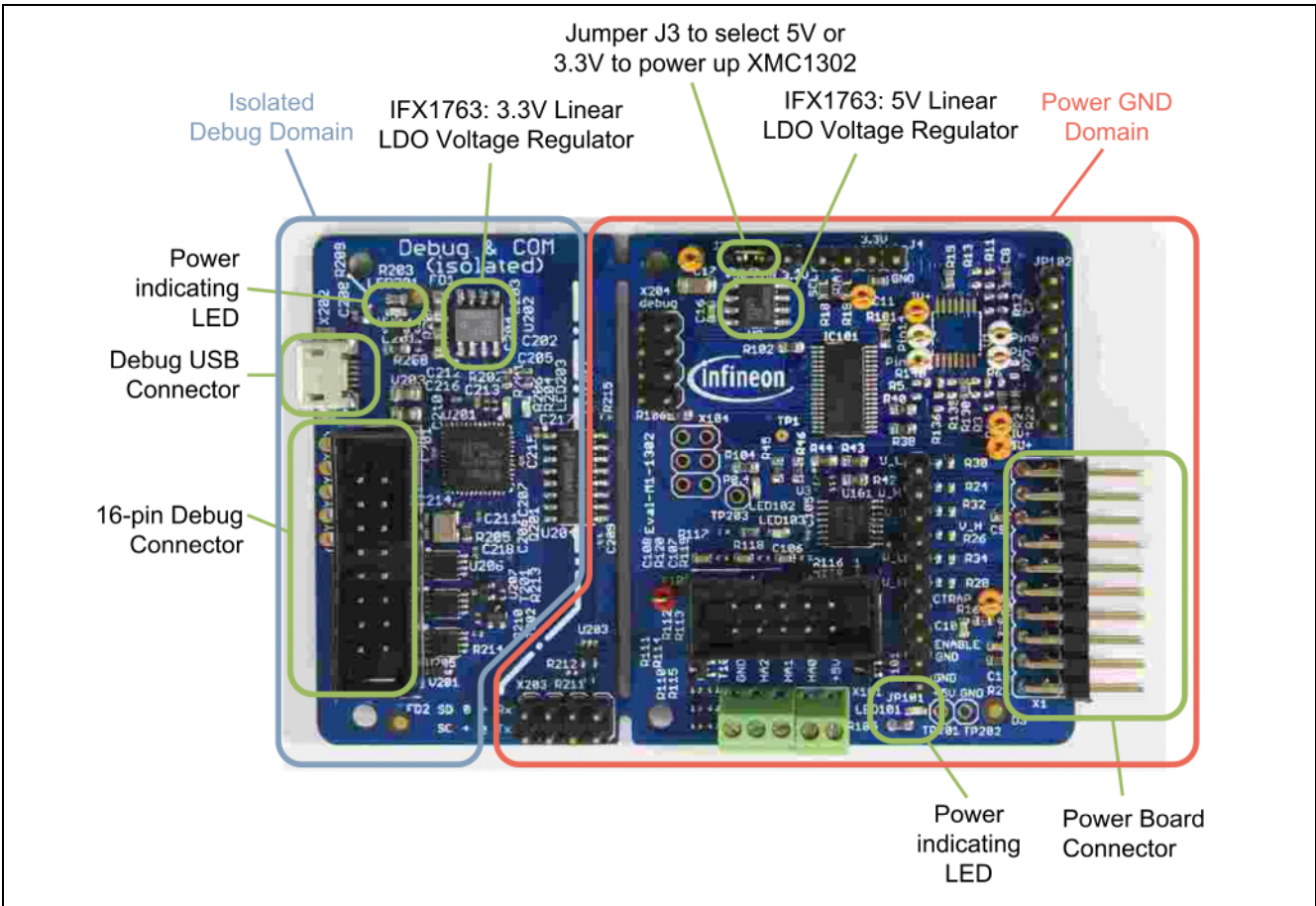

Figure 3 The two isolated power supply domains of Eval-M1-1302

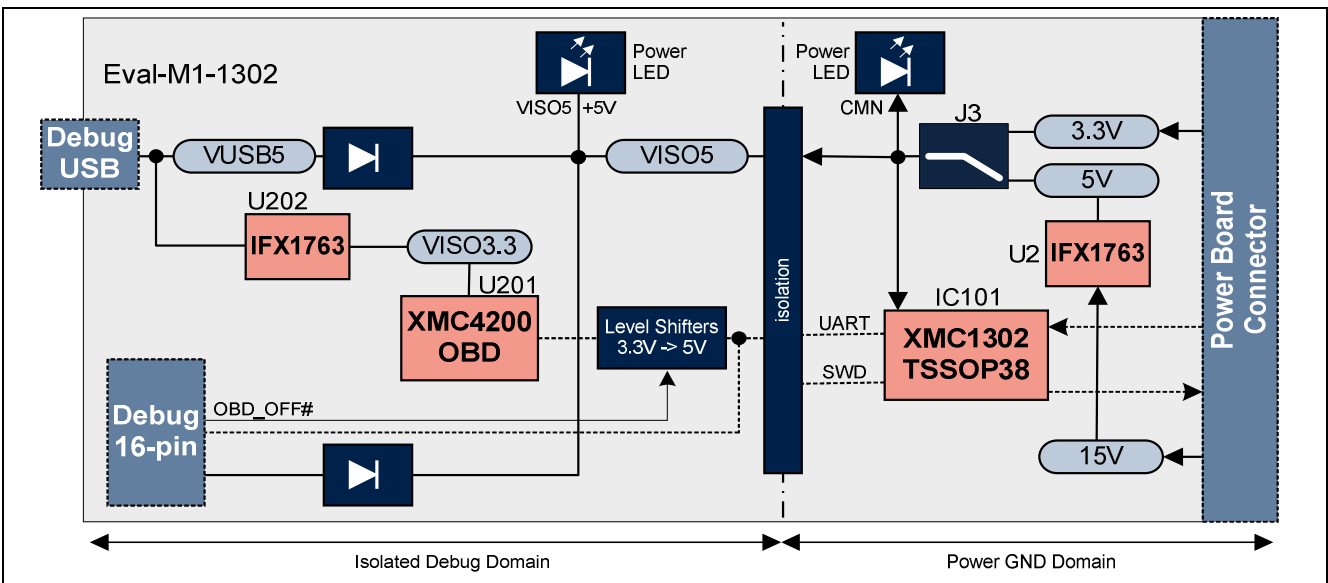

Figure 4 Block Diagram of the Power Supply Concept

Eval-M1-1302

For iMOTION™ Modular Application Design Kit

Hardware Description

2.2 Clock Generation

An internal oscillator provides the clock signal to the XMC1302 microcontroller. The CPU can be adjusted to a maximum of 32MHz (MCLK) whereas the PWM peripherals can be configured to use twice this frequency (PCLK).

2.3 Debug Interface

The Eval-M1-1302 is designed to use Serial Wire Debug (SWD) or Single Pin Debug (SPD) as debug interfaces. It supports debugging via different channels which are all galvanically isolated from the power GND supply domain:

- On-board debugger
- 16-pin debug connector with Debug and UART interface

2.3.1 On-board USB debugger

The on-board debugger supports

- Serial Wire Debug (SWD)
- Single Pin Debug (SPD)
- Full Duplex UART communication via a Virtual COM port
 - PC_RXD P1.2 USIC0CH1.DOUT0
 - PC_TXD P1.3 USIC0CH1.DX0A

The on-board debugger can be accessed through the Debug USB connector. The Debug LED (LED202) signals the status during debugging.

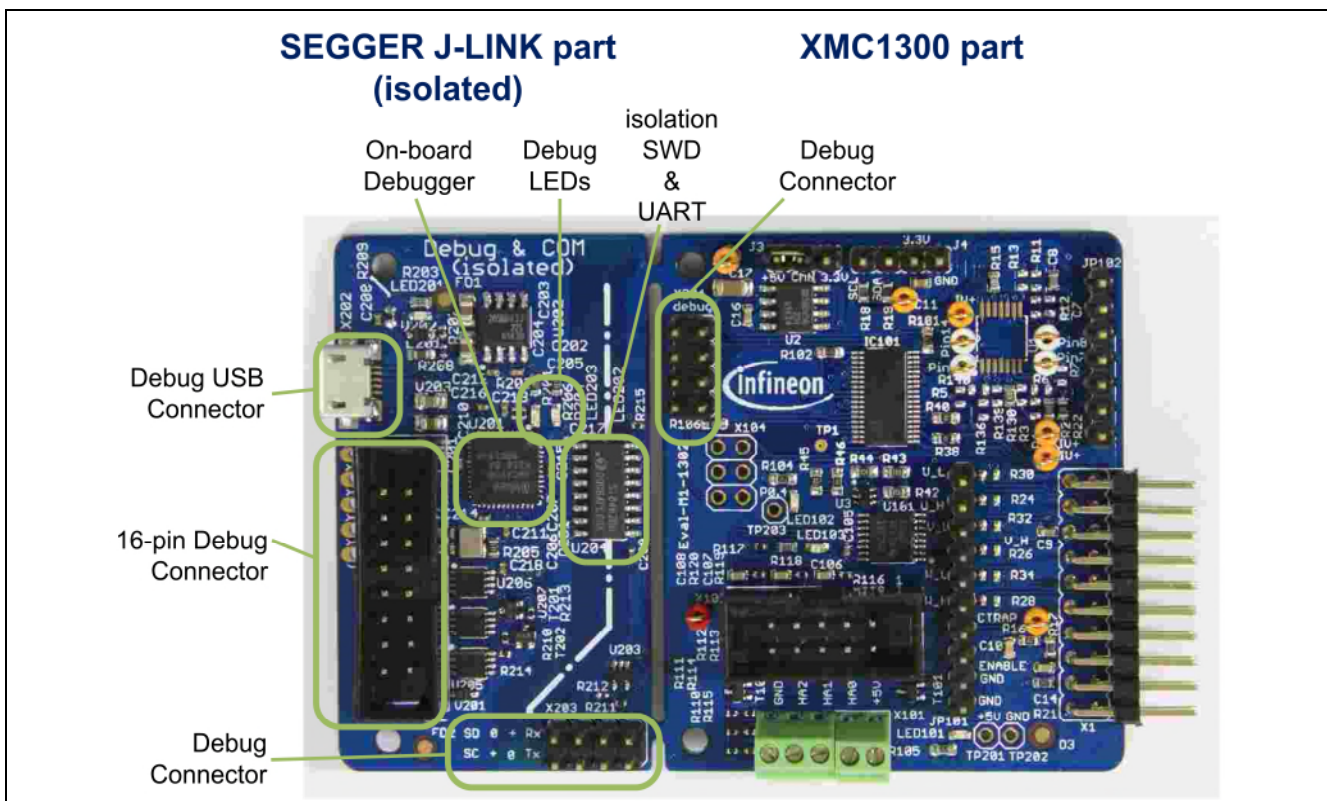

Figure 5 On-board USB debugger and its connectors

Hardware Description

When using an external debugger connected to the 16-pin debug connector, the on-board debugger has to be switched off. This is done by connecting pin 6 of the debug connector to GNDISO.

2.3.2 8-pin Debug Connector

The Eval-M1-1302 supports debugging via SWD and SPD with the OBD as described in section 2.3.1. Please refer to Figure 6 for details on pin assignment.

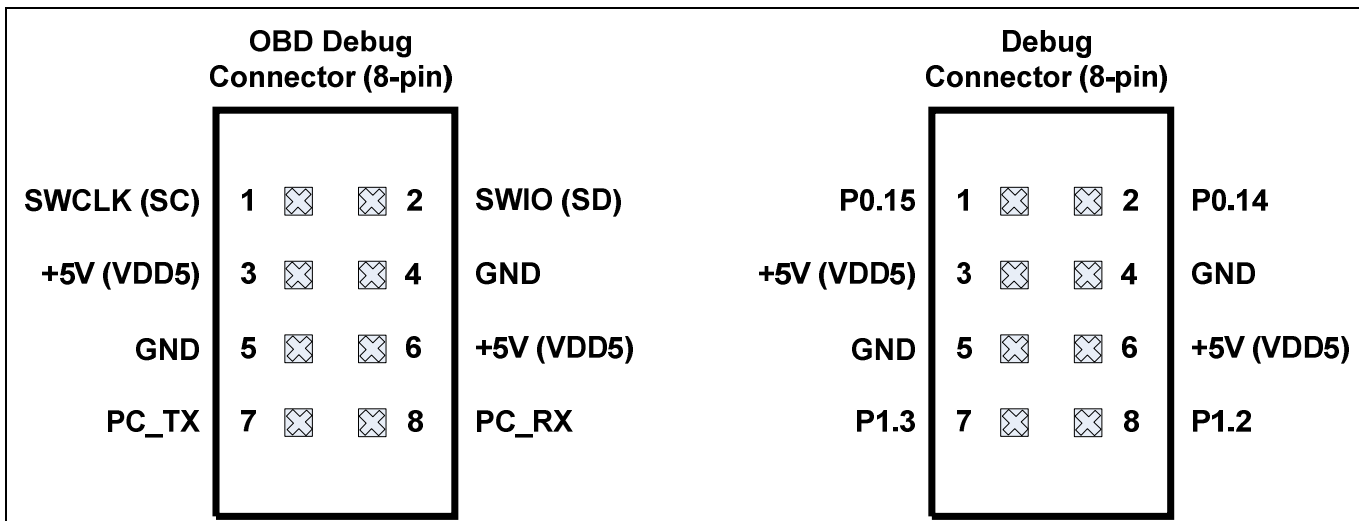

Figure 6 Pin assignment of the 8-pin debug connector

The default connections used in the Eval-M1_1302 are:

- Serial Wire Debug (SWD)
 - SWIO/SPD P0.14 (SWD0)
 - SWCLK P0.15 (SWD0)
- Full Duplex UART communication via a virtual COM port
 - PC_RXD P1.2 USIC0CH1.DOUT0
 - PC_TXD P1.3 USIC0CH1.DX0A

2.3.3 16-pin Debug Connector

The Eval-M1-1302 supports debugging via Infineon’s device access server (DAS), when using the DriveMonitor USB Stick V2 as interface device. The latest release of the DAS software can be downloaded from <http://www.infineon.com/das>. When using an external debugger, the on-board debugger (OBD) has to be switched off. This is done by connecting pin 6 to GNDISO. The DriveMonitor USB Stick V2 already provides this connection and the OBD is disabled as soon as the connector is plugged in.

Hardware Description

Next to the SWD and SPD debug signals which are provided as unidirectional signals because of the galvanic isolation, UART signals can be accessed through this connector as well.

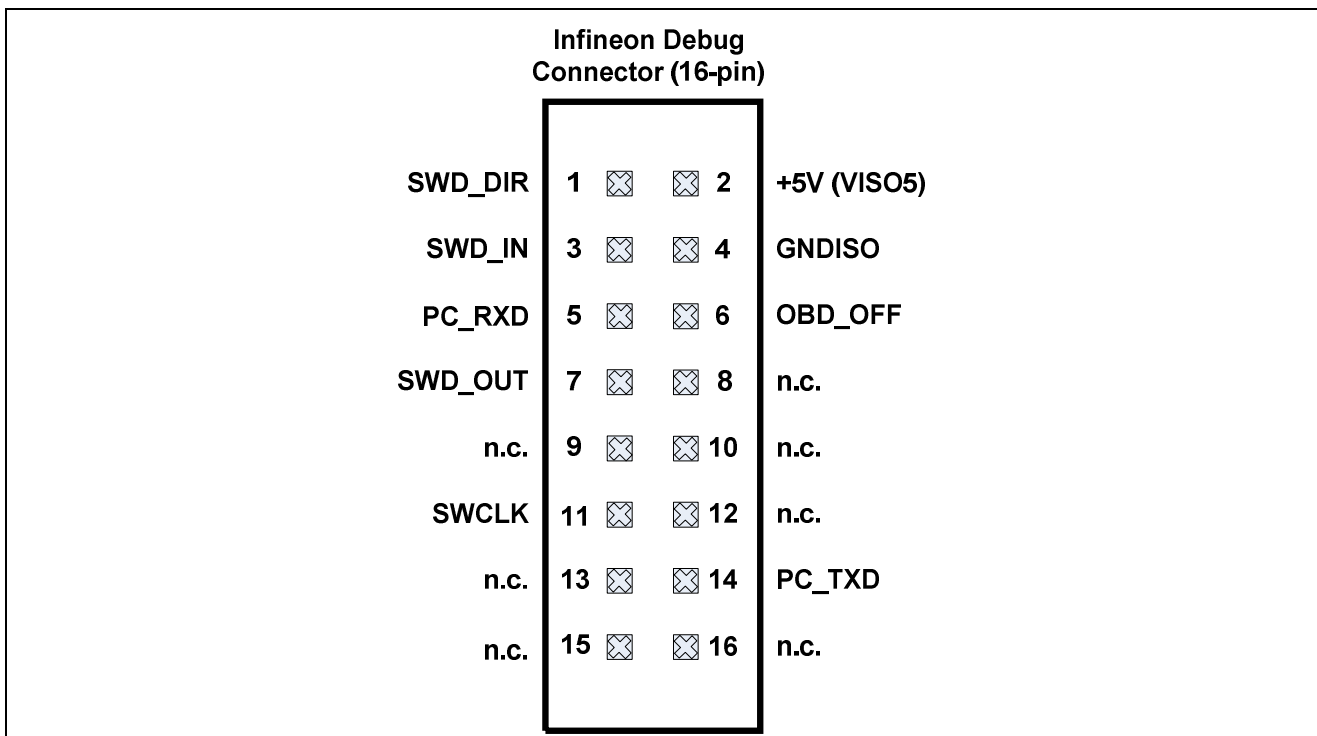

Figure 7 16-pin Debug Connector

Table 2 Pin out description of the Infineon Debug Connector, X201

Pin No.	Signal Name	I/O	Serial Wire Debug
1	SWD_DIR	O	Defines the direction of SWIO
2	+5V (VISO5)	-	+5V supply of isolated debug domain
3	SWD_IN	I	Input signal of SWIO
4	GNDISO	-	Ground of the isolated debug domain
5	PC_RXD	I	UART Receive signal (P1.3, DOUT0 USIC0, channel1)
6	OBD_OFF#	I	Disable on-board debug device (Low active)
7	SWD_OUT	O	Output signal of SWIO
8	n.c.	-	Not connected
9	n.c.	-	Not connected
10	n.c.	-	Not connected
11	SWCLK	O	SWD clock signal
12	n.c.	-	Not connected
13	n.c.	-	Not connected
14	PC_TXD	I	UART Transmit signal (P1.2, DX0A, USIC0, channel1)
15	n.c.	-	Not connected
16	n.c.	-	Not connected

2.4 USIC Connector

The USIC Interface provides access to USIC0 channel0 which supports SPI, UART and I²C communication protocols. Figure 8 indicates the pin assignment of the USIC interface connector, X104.

Eval-M1-1302

For iMOTION™ Modular Application Design Kit

Hardware Description

The USIC module is a peripheral inside the XMC1302 device. Table 3 gives the USIC signal name for the port pin used in X104 and cautions that some pins are used in another circuitry. For example, if P0.10 is used for SPI interface, then ENENC signal cannot be used for motor position sensing.

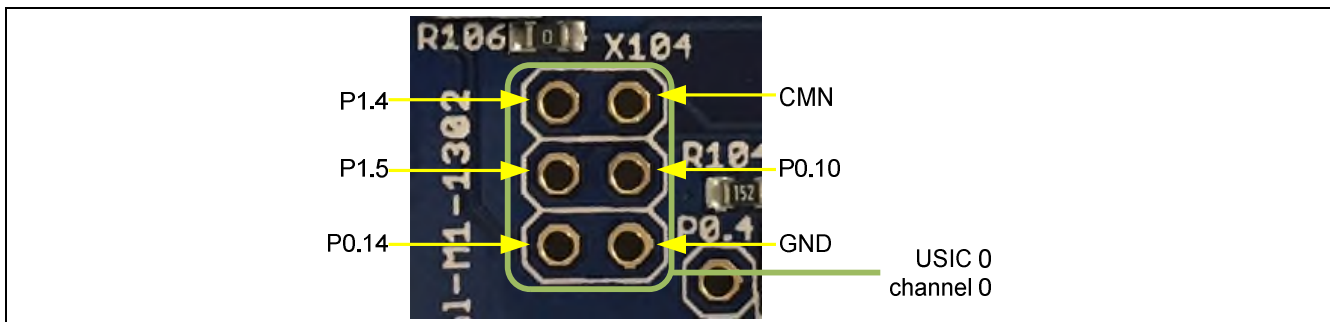

Figure 8 USIC Interface Connector X104

Table 3 USIC0 Connector X104

Pin	Port	Peripherals	Comment
X104-1	P1.4	USIC0_CH0.DX5E	
X104-2	CMN	5V/3.3V	3.3V or 5V depending on J3 setting
X104-3	P1.5	USIC0_CH0.DOUT0	
X104-4	P0.10	USIC0_CH0.SELO1 / DX2C	Overlaps with ENENC
X104-5	P0.14	USIC0_CH0.SCLKOUT	Overlaps with SWD0/SPD0
X104-6	GND	GND	

2.5 Hall Sensor and Encoder Connectors

The Eval-M1-1302 provides HALL and incremental encoder connectors as indicated in Figure 9. The encoder interface connector provides a differential input which is transformed into single ended signals by an interface IC. The HALL sensor interface provides a pull-up resistor for each HALL sensor signal as well as power supply for the HALL sensors

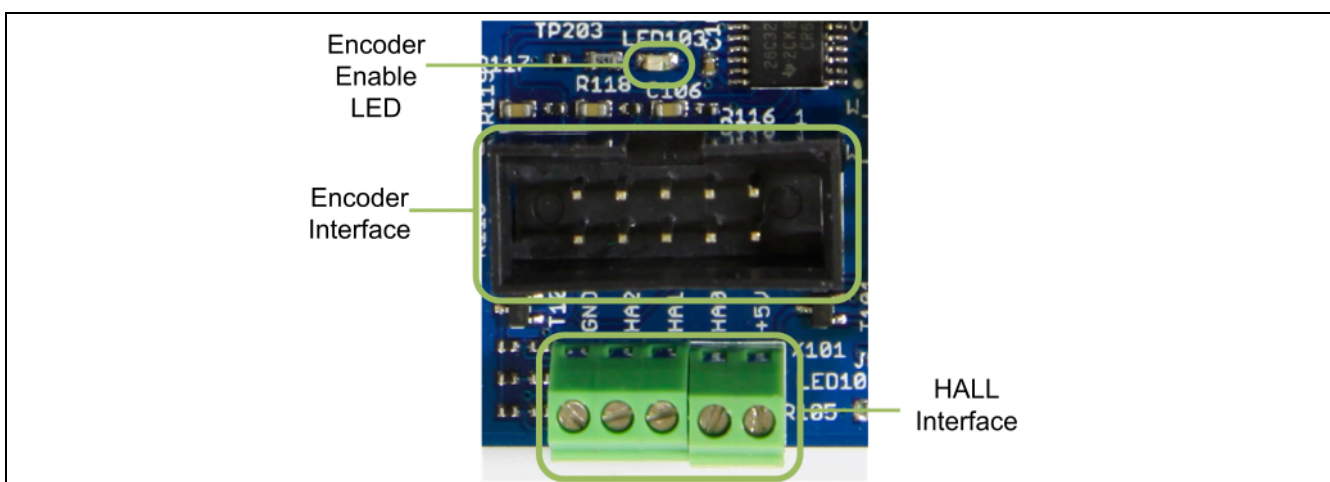

Figure 9 Hall Sensor and Encoder Connectors

Both the HALL and the encoder signal are connected to the same POSIF interface. The ENENC-signal is used to either enable the output signals of the encoder IC or to activate the power supply and pull-up resistor supply of the HALL sensor interface. As a result, both interfaces can be connected at the same time and the user can select by software which interface to use.

Hardware Description

In Figure 10, the HALL sensor and encoder interface circuitry is provided. Please refer to Table 4 for details on pin and peripheral assignment.

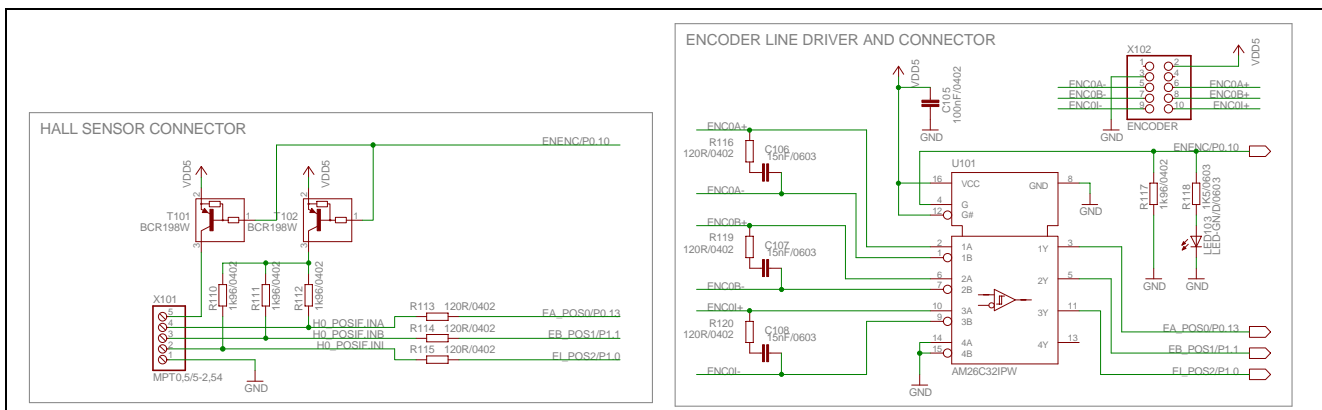

Figure 10 Hall-effect position sensor and Encoder interface circuitry

Table 4 HALL Sensor and Encoder Interfaces

Pin	Port	Peripheral
HALL Sensor Interface X101		
1	GND	
2	P1.0	POSIF0.IN2A
3	P1.1	POSIF0.IN1B
4	P0.13	POSIF0.IN0B
5	CMN	HALL sensor power supply, usually 5V
Encoder Interface X102		
1	n.c.	
2	CMN	Encoder power supply, usually 5V
3	GND	
4	n.c.	
5	ENCA-	POSIF0.IN0B
6	ENCA+	
7	ENCB-	POSIF0.IN1B
8	ENCB+	
9	ENCI-	POSIF0.IN2A
10	ENCI+	
Enable Encoder		
LED103	P0.10	High: Enable Encoder Interface Low: Enable HALL Interface including supply

2.6 Power Board Connector

The Eval-M1-1302 provides a power board connector with all the signals required to control the power board. The interface features the PWM output signals of CCU4 and CCU8 as well as the ADC signals. The power supply pins for the power GND domain are also included.

Figure 11 displays a picture of Eval-M1-1302 board with the power connector highlighted. The pin and peripheral assignment can be found in Table 5.

Production Data



Figure 11 The power board connector

Table 5 Pin assignment of Power Board Connector X1

X1 2.54mm pitch	Function on Power Inverter	Port	Peripherals	
A1	U_H	P0.0	CCU80.OUT00	
A2	GND	VSS, VSSP		
A3	U_L	P0.1	CCU80.OUT01	
A4	GND	VSS, VSSP		
A5	V_H	P0.7	CCU80.OUT10	
A6	3.3V	VDD, VDDP		
A7	V_L	P0.6	CCU80.OUT11	
A8	3.3V	VDD, VDDP		
A9	W_H	P0.8 & P0.2	CCU80.OUT20	CCU80.OUT02
A10	I _{U+}	P2.9	VADC0.G0CH2	VADC0.G1CH4
A11	W_L	P0.9 & P0.3	CCU80.OUT21	CCU80.OUT03
A12	I _{U-}	GND		
A13	CTRAP/P0.12	-		
A14	V _{DCLink}	P2.3		VADC0.G1CH5
A15	VTH	P2.7		VADC0.G1CH1
A16	I _{V+}	P2.10	VADC0.G0CH3	VADC0.G1CH2
A17	I _{V-}	GND		
A18	I _{W+}	P2.11	VADC0.G0CH4	VADC0.G1CH3
A19	I _{W-}	GND		
A20	VCC 15V	-		

3 Production Data

The schematic, silkscreen and bill of material for the Eval-M1-1302 are given in this chapter. This information is important for troubleshooting of this board.

3.1 Schematics

This section contains the schematics for the Eval-M1-1302 board:

Production Data

- Schematics: XMC1302 MCU, Power Supply, HALL and Encoder Interface, USIC0 interface
- Schematics: Isolated on-board debugger

The board has been designed with Eagle. The full PCB design data of this board can also be downloaded from www.infineon.com/madk.

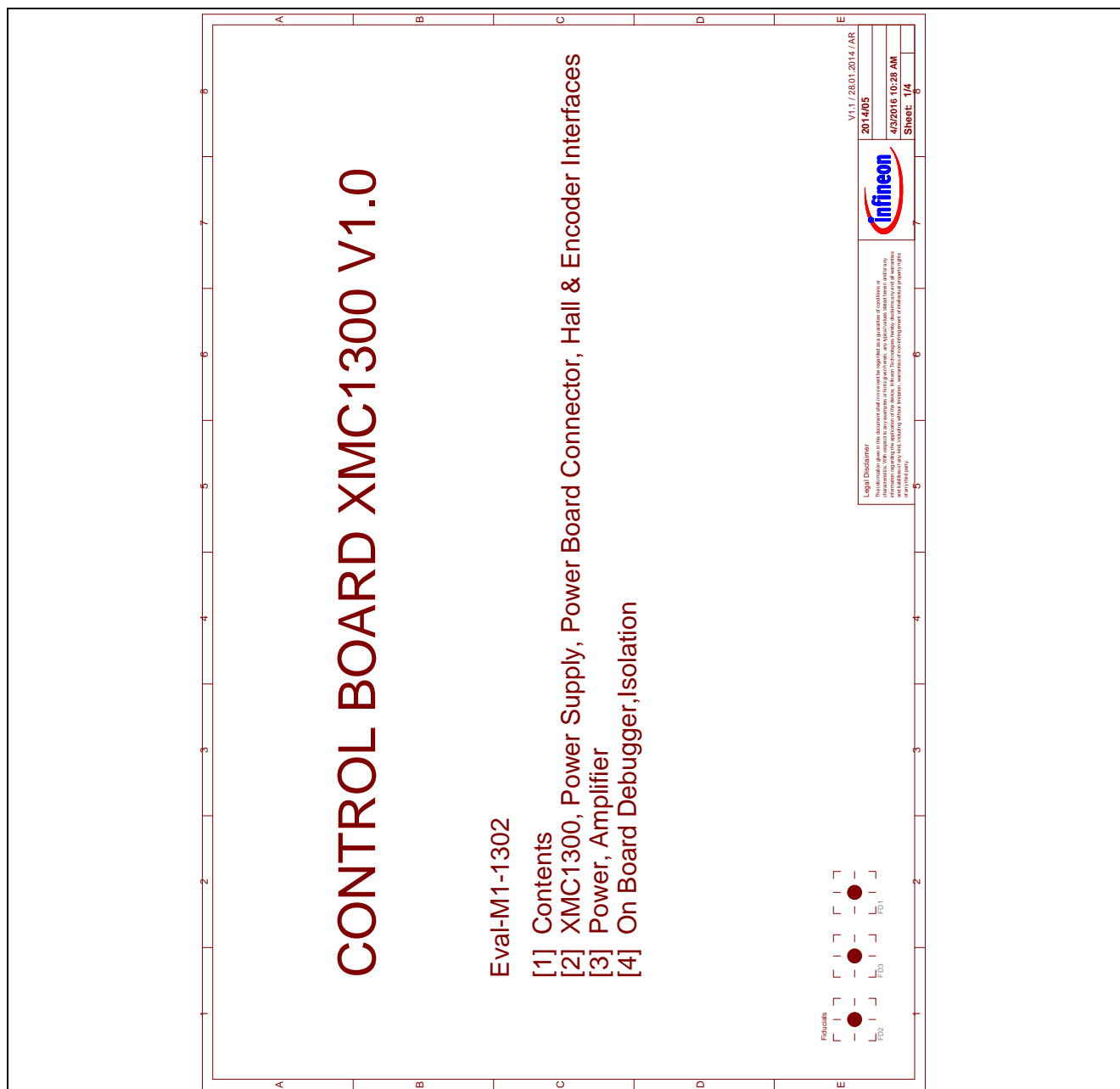

Figure 12 Schematics: Title Page

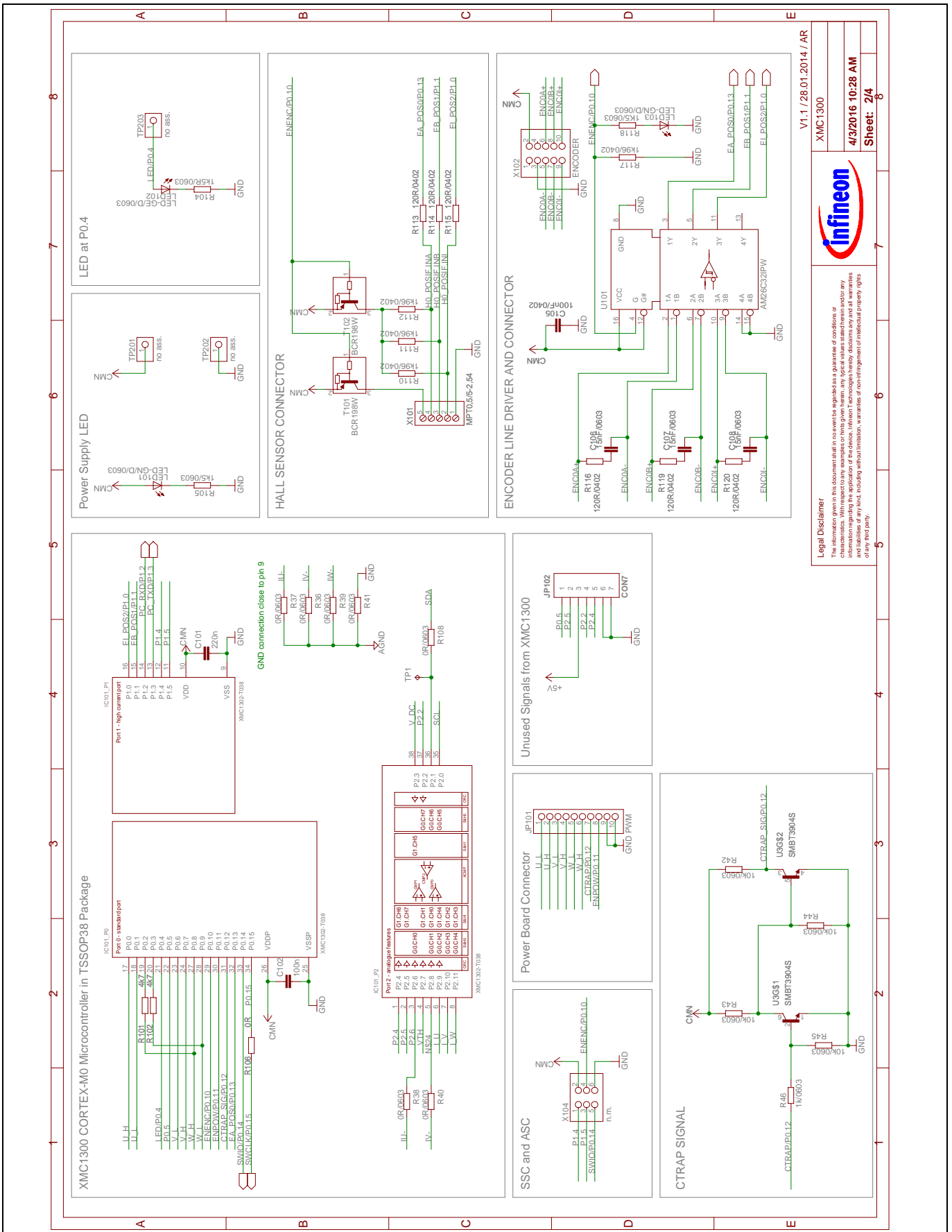

Figure 13 Schematics: XMC1302 MCU, Power Supply, HALL and Encoder Interface, USIC0 interface

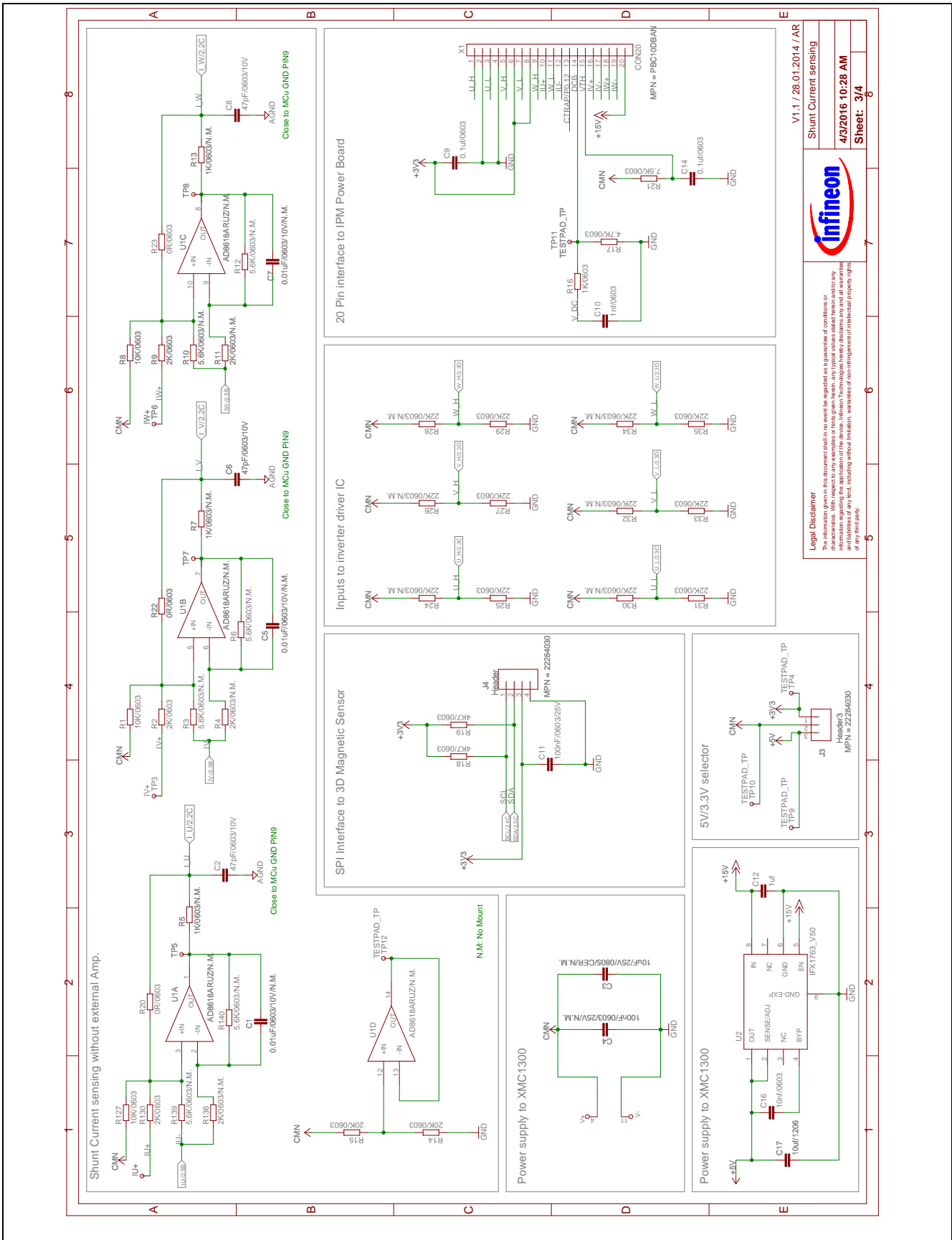

Figure 14 Schematics: Interface to inverter board, 5V power supply, PWM signal-lines to the inverter board

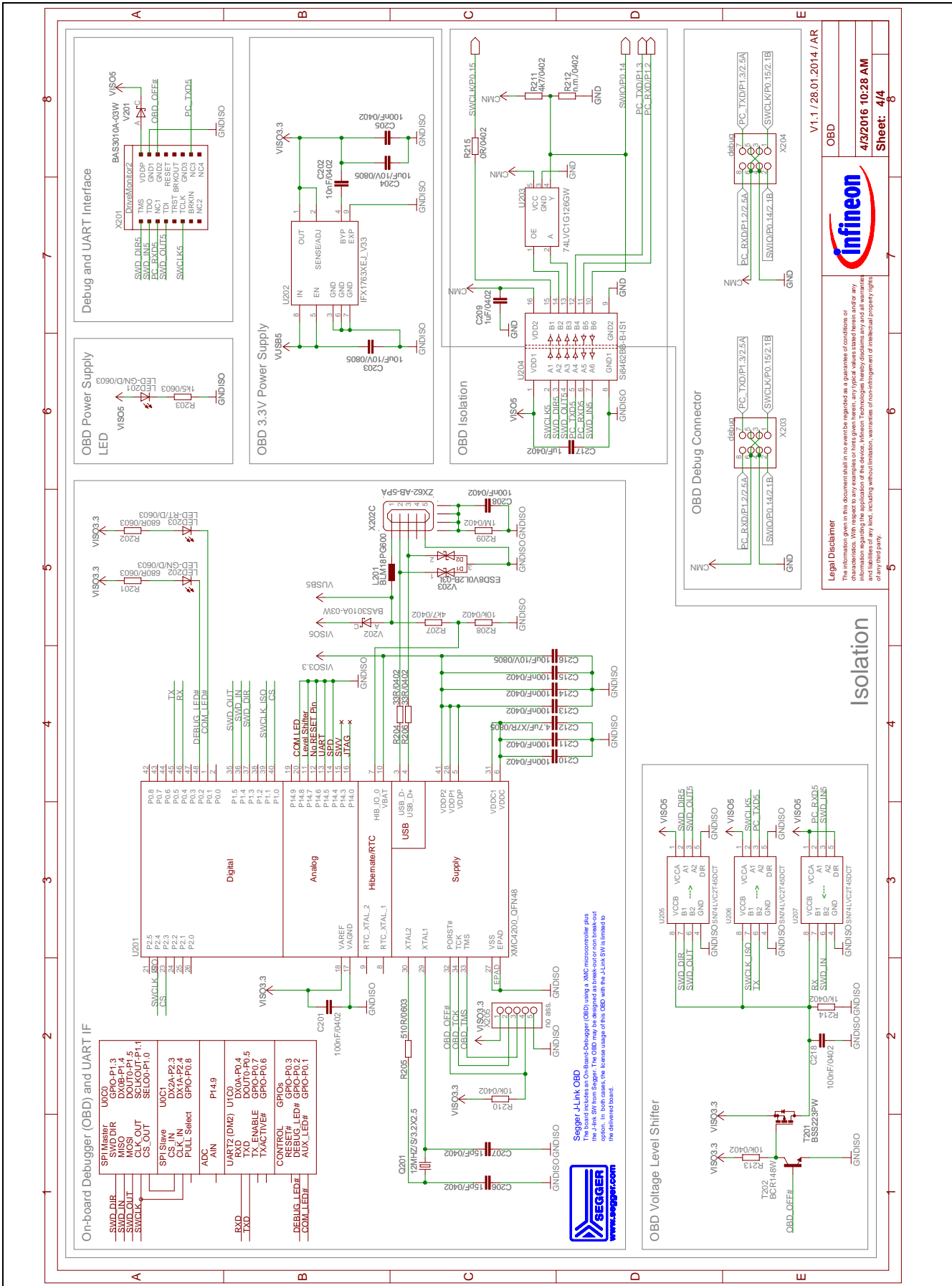

Figure 15 Schematics: Isolated on-board debugger

3.2 Component Placement and PCB layout

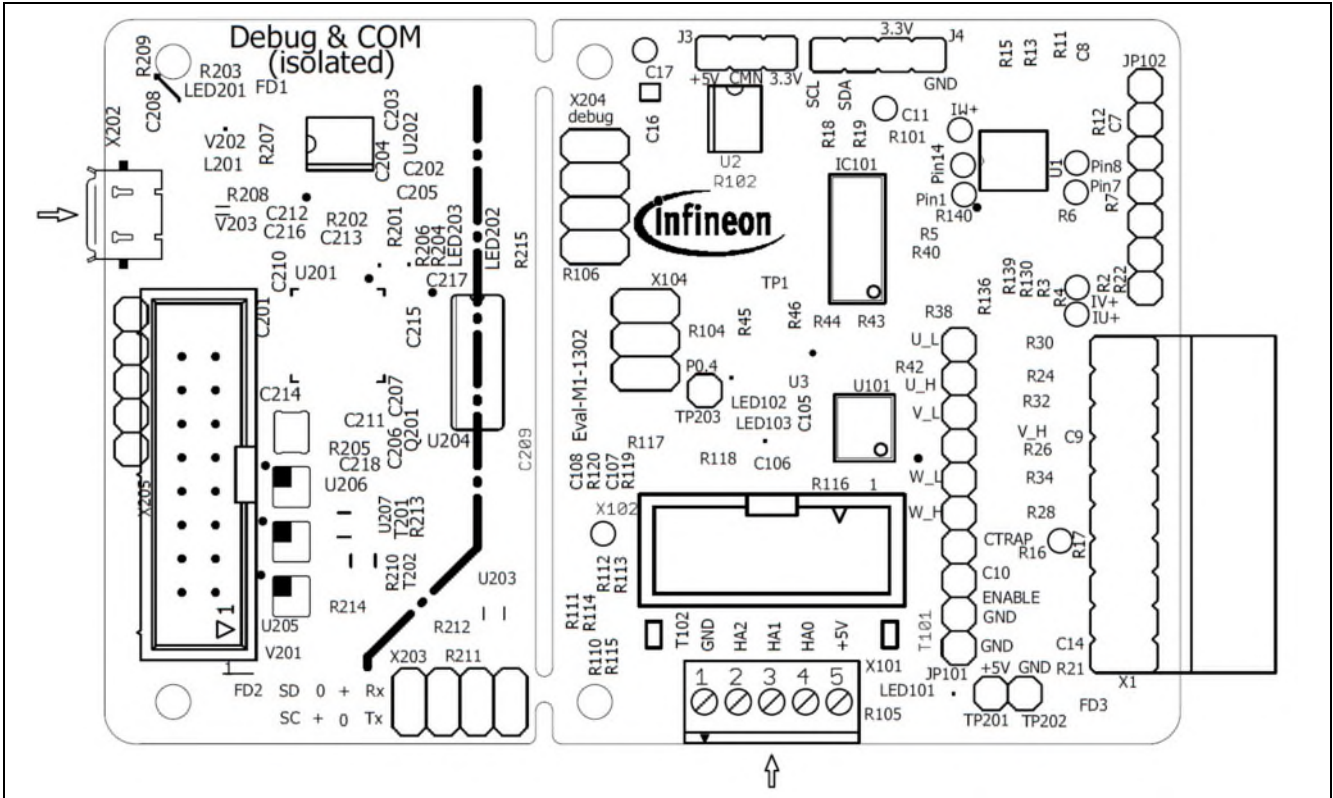

Figure 16 Component Placement

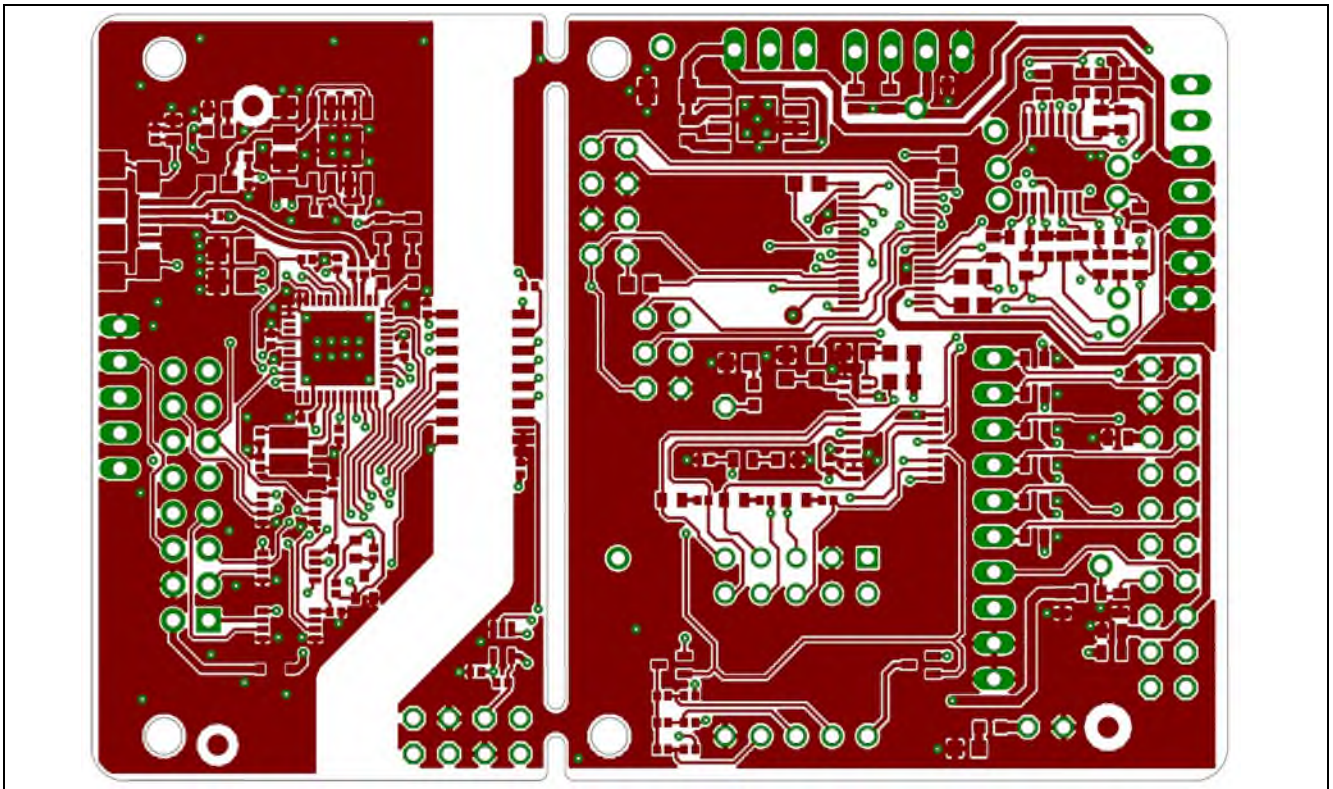

Figure 17 Top layer of Eval-M1-1302

Production Data

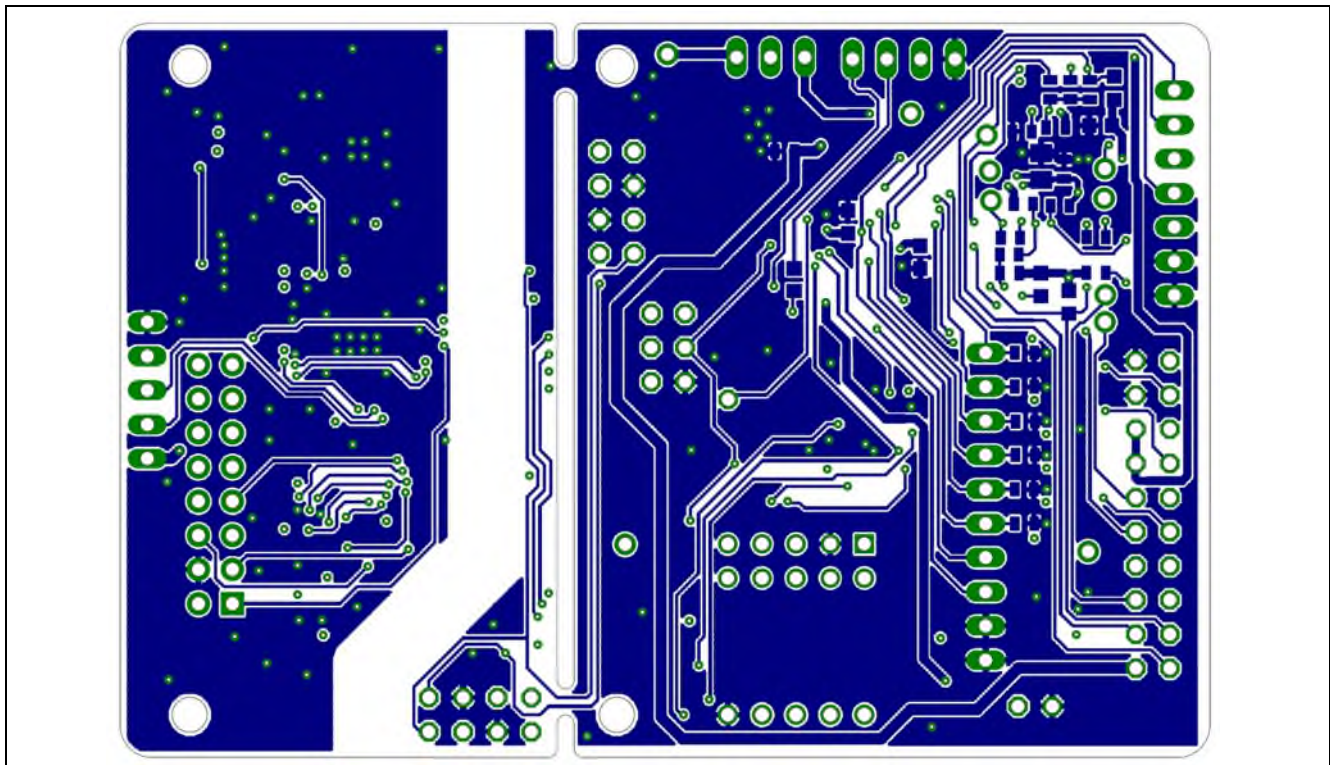

Figure 18 Bottom layer of Eval-M1-1302

3.3 Bill of Material (BOM)

Table 6 BOM of Eval-M1-1302

Pos. No.	Qty	Value	Device	Reference Des.
1	5	4k7/0603	RESISTOR 0603	R17,R18,R19,R101,R102
2	11	0R/0603	RESISTOR 0603	R106,R20,R22,R23,R36,R37,R38,R39,R40, R41,R108
3	4	1k96/0402	RESISTOR 0402	R110, R111, R112, R117
4	6	120R/0402	RESISTOR 0402	R113, R114, R115, R116, R119, R120
5	2	1k/0603	RESISTOR 0603	R16,R46
6	4	1k5/0603	RESISTOR 0603	R104,R105,R118,R203
7	3	2k/0603	RESISTOR 0603	R2,R9,R130
8	2	680R/0603	RESISTOR 0603	R201, R202
9	2	33R/0402	RESISTOR 0402	R204, R206
10	1	510R/0603	RESISTOR 0603	R205
11	1	7k5/0603	RESISTOR 0603	R21
12	7	10k/0603	RESISTOR 0603	R1,R8,R42,R43,R44,R45,R127
13	8	20k/0603	RESISTOR 0603	R14,R15,R25,R27,R29,R31,R33,R35
14	2	4k7/0402	RESISTOR 0402	R207, R211
15	3	10k/0402	RESISTOR 0402	R208, R210, R213
16	1	1M/0402	RESISTOR 0603	R209
17	1	1k/0402	RESISTOR 0402	R214
18	1	0R/0402	RESISTOR 0402	R215
19	3	47pF/0603/10V	CAPACITOR 0603	C2,C6,C8
20	1	220nF	CAPACITOR 0603	C101
21	3	100nF/0603	CAPACITOR 0603	C9,C14,C102

Eval-M1-1302
For iMOTION™ Modular Application Design Kit



Production Data

22	1	100nF/0603/25V	CAPACITOR 0603	C11
23	10	100nF/0402	CAPACITOR 0402	C105, C201, C205, C208, C210, C211, C213, C214, C215, C218
24	1	1nF/0603	CAPACITOR 0603	C10
25	3	15nF/0603	CAPACITOR 0603	C106, C107, C108
26	1	10nF/0402	CAPACITOR 0402	C202
27	1	10nF/0603	CAPACITOR 0603	C16
28	3	10µF/10V/0805	CAPACITOR 0805K	C203, C204, C216
29	2	15pF/0402	CAPACITOR 0402	C206, C207
30	1	1µF/0603	CAPACITOR 0603	C12
31	2	1µF/0402	CAPACITOR 0402	C209, C217
32	1	4.7µF/X7R/0805	CAPACITOR 0805K	C212
33	1	10µF/1206	CAPACITOR 1206	C17
34	1	12MHZ/S/3.2X2.5	CRYSTAL	Q201
35	1	BLM18PG600	FERRIT BEAD	L201
36	4	LED-GN/D/0603	LEDCHIPLED 0603	LED101, LED103, LED201, LED202
37	1	LED-GE/D/0603	LEDCHIPLED 0603	LED102
38	1	LED-RT/D/0603	LEDCHIPLED 0603	LED203
39	2	BCR198W	TRANSISTOR	T101, T102
40	1	BSS223PW	TRANSISTOR	T201
41	1	BCR148W	TRANSISTOR	T202
42	1	XMC1302-T038X0200 AB	INFINEON MCU	IC101
43	1	HEADER 1X4	CONNECTOR	J4
44	1	HEADER 1X3	CONNECTOR	J3
45	1	IFX1763XEJ_V33	INFINEON LDO	U202
46	1	IFX1763XEJ_V50	INFINEON LDO	U2
47	1	AM26C32IPW	ENCODER IC	U101
48	1	XMC4200_QFN48	INFINEON MCU	U201
49	1	Si8462BB-B-IS1	6-channel digital isolator IC	U204
50	11	SMBT3904S	TRANSISTOR	U3
51	1	74LVC1G126GW	LOGIC-IC	U203
52	3	SN74LVC2T45DCT	LOGIC-IC	U205, U206, U207
53	2	BAS3010A-03W	BAT60	V201, V202
54	1	ESD8V0L2B-03L	ESD DIODE	V203
55	1	CONNECTOR OCDS	CONNECTOR	X201
56	1	ZX62-AB-5PA	MICRO-USB	X202
57	1	HEADER 1X10	CONNECTOR	JP101
58	1	HEADER 1X7	CONNECTOR	JP102
59	1	CONP_2X05	CONNECTOR	X102
60	1	HEADER 2X10 RIGHT ANGLE	CONNECTOR	X1
61	1	MPT0,5/5-2,54	CONNECTOR	X101



Revision History

Revision History

Major changes since the last revision

Page or Reference	Description of change
V1.0	Initial Version

Trademarks of Infineon Technologies AG

AURIX™, C166™, CanPAK™, CIPOS™, CoolGaN™, CoolMOS™, CoolSET™, CoolSiC™, CORECONTROL™, CROSSAVE™, DAVE™, DI-POL™, DrBlade™, EasyPIM™, EconoBRIDGE™, EconoDUAL™, EconoPACK™, EconoPIM™, EiceDRIVER™, eupec™, FCOS™, HITFET™, HybridPACK™, Infineon™, ISOFACE™, IsoPACK™, i-Wafer™, MIPAK™, ModSTACK™, my-d™, NovalithIC™, OmniTune™, OPTIGA™, OptiMOS™, ORIGA™, POWERCODE™, PRIMARION™, PrimePACK™, PrimeSTACK™, PROFET™, PRO-SIL™, RASIC™, REAL3™, ReverSave™, SatRIC™, SIEGET™, SIPMOS™, SmartLEWIS™, SOLID FLASH™, SPOC™, TEMPFET™, thinQ!™, TRENCHSTOP™, TriCore™.

Trademarks updated August 2015

Other Trademarks

All referenced product or service names and trademarks are the property of their respective owners.

Edition 2016-08-19

Published by

**Infineon Technologies AG
81726 Munich, Germany**

**© 2016 Infineon Technologies AG.
All Rights Reserved.**

Do you have a question about this document?

Email: erratum@infineon.com

**Document reference
AN2016-22**

IMPORTANT NOTICE

The information contained in this application note is given as a hint for the implementation of the product only and shall in no event be regarded as a description or warranty of a certain functionality, condition or quality of the product. Before implementation of the product, the recipient of this application note must verify any function and other technical information given herein in the real application. Infineon Technologies hereby disclaims any and all warranties and liabilities of any kind (including without limitation warranties of non-infringement of intellectual property rights of any third party) with respect to any and all information given in this application note.

The data contained in this document is exclusively intended for technically trained staff. It is the responsibility of customer's technical departments to evaluate the suitability of the product for the intended application and the completeness of the product information given in this document with respect to such application.

For further information on the product, technology, delivery terms and conditions and prices please contact your nearest Infineon Technologies office (www.infineon.com).

Please note that this product is not qualified according to the AEC Q100 or AEC Q101 documents of the Automotive Electronics Council.

WARNINGS

Due to technical requirements products may contain dangerous substances. For information on the types in question please contact your nearest Infineon Technologies office.

Except as otherwise explicitly approved by Infineon Technologies in a written document signed by authorized representatives of Infineon Technologies, Infineon Technologies' products may not be used in any applications where a failure of the product or any consequences of the use thereof can reasonably be expected to result in personal injury.