

ISL78693EVAL1Z Evaluation Board User Guide

Description

The ISL78693EVAL1Z is a complete platform for the evaluation of all datasheet specifications and functionalities. The onboard 8-bit DIP switch facilitates battery charge current programming, setting EN input, temperature monitoring status, etc. The four jumpers can set up the input source selection, USB mode selection, USB mode selection, and can be used to make other necessary connections.

The ISL78693EVAL1Z board is intended to provide an evaluation platform for the 3mmx3mm DFN [ISL78693](#) package, single-cell Li-ion battery charger.

The device along with key components, constitute a complete charger solution demonstrating the space saving advantage of the ISL78693 in limited space applications.

LEDs connected to STATUS and FAULT pins will indicate the normal charging status or fault condition.

Onboard jumpers and a DIP switch allow the different operating conditions for the charger.

Specifications

This board has been configured and optimized for the following operating conditions:

- Ambient temperature range, -40 °C to +85 °C
- Supply voltage, $V_{IN} = 4.3V$ to $5.5V$
- Output voltage, $V_{BAT} = 3.65V$
- Trickle charge voltage, $2.6V$
- Recharge threshold voltage, $3.3V$
- Constant charge current up to $0.5A$

Features

- Complete charger for single-cell Li-ion batteries
- Integrated pass element and current sensor
- No external blocking diode required
- 1% voltage accuracy
- Programmable current limit up to $0.5A$
- NTC thermistor interface for battery temperature monitor, 8-bit DIP switch for conveniently setting up charging current, battery thermal status, EN input, etc
- Different jumpers for input source selection, USB mode selection, and the convenience of current measurement
- Test points provided for STATUS, FAULT, TIME, EN, V2P8, and TEMP functional pins to allow for monitoring the device pins
- Board size $3.5" \times 2.5"$ for the convenience of evaluation
- Eight thermal vias in the thermal pad
- RoHS compliant

Related Literature

- For a full list of related documents please visit our website - [ISL78693](#) product page

Ordering Information

PART #	DESCRIPTION
ISL78693EVAL1Z	Evaluation board for the 3x3 DFN package part

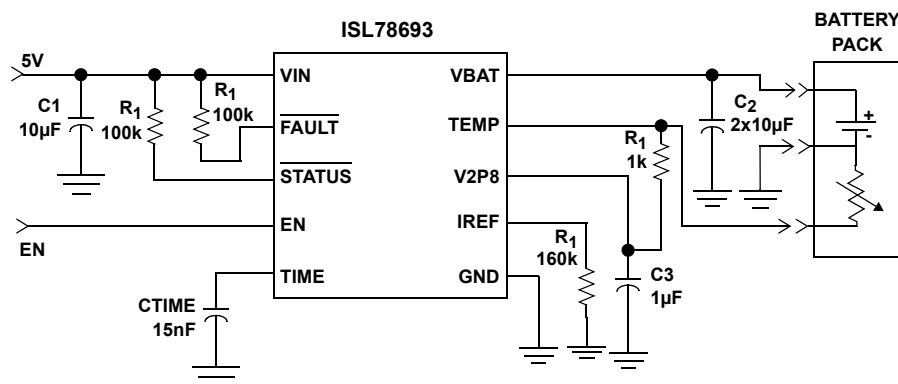

FIGURE 1. TYPICAL APPLICATION

What Is Inside

The evaluation board is shipped with:

- [ISL78693](#) datasheet
- This ISL78693EVAL1Z user guide

What Is Needed

The following instruments will be needed to perform testing:

- Power supplies:
 - PS1: DC 20V/5A,
 - PS2: DC (sinks current) 20V/5A, such as Agilent 6654A
- Electronic load: 20V/5A
- Multimeters
- Function generator
- Oscilloscope
- Cables and wires

Quick Setup Guide

1. Switch on Bits 4 and 6 of the DIP-switch. Leave all other bits off, see [Figure 2](#).

****DO NOT APPLY POWER UNTIL STEP 6****

2. Connect 5V to VIN.
3. Connect 3.25V to VBAT.
4. Connect 1.2A electronic load to VBAT.
5. Verify that no shunts are connected across all jumpers.
6. Turn on power supplies and electronic load.
7. Green LED should be on, indicating normal charging operation.
8. If current meter is in series with VIN, it shall read 400mA as the charging current.
9. Turn ON DIP-2 bit, VBAT will read 0V, IBAT will read 0A, and the green LED is OFF.
10. Turn OFF DIP-2 bit, switch off all supplies.

DIP Switch Settings

A 9-bit DIP switch is provided to set up the voltage, current reference, End-of-Charge (EOC) current, and so on. The functionality of the bits are described in [Table 2](#).

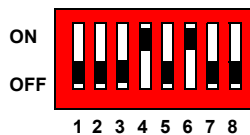

FIGURE 2. INITIAL DIP SWITCH SETTINGS

TABLE 1. JUMPER SETTINGS

JUMPER	POSITION	FUNCTION
JP1	USB to VIN	USB connection
	Wall Cube to VIN	Wall adapter connection
JP2	Installed	Connect VBAT pin to battery Current meter can replace shunt
	Not Installed	Default
JP3	Not Installed	Default
	Installed	Battery attached to thermistor at J2
JP4	IREF and V2P8	USB 500mA
	IREF and GND	USB 100mA

TABLE 2. DIP SWITCH PIN DESCRIPTIONS

BIT	DESCRIPTION	ON	OFF	REMARK
1	Adjustable TIMEOUT	5 hours 50 mins	3 hours 30 mins	
2	Charger Enable/Disable	Charger disabled	Charger enabled	
3	I _{REF} Setting 1	Add 0.5A		
4	I _{REF} Setting 2	Add 0.4A		
5				Not connected
6	TEMP Normal	Normal		All off simulates battery removal
7	TEMP High	Too hot		
8	TEMP Low	Too cold		

Initial Board Jumper Positioning (Refer to [“Schematic” on page 5](#))

JP1 - Selects the VIN pin connection to a wall adapter, or to USB connector. If the J1 connector is being used, a shunt must be installed across JP1-1, 2. If J3 (USB) connector is being used, a shunt must be installed across JP1-2, 3. J1, J3, and JP1 can be ignored if the power supply is connected directly to the VIN test point, which is directly connected to the VIN pin of the IC. A current meter can replace the shunt mentioned above, in order to measure the input current.

JP2 - Connects the VBAT pin to the battery. If the J2 connector is being used, a shunt must be installed across JP2. A current meter can also replace the shunt to measure the V_{BAT} current.

JP3 - Connects the TEMP pin to the battery. Usually no shunt is needed for JP3, as the evaluation board can simulate various battery thermal conditions. Only when a battery attached with a thermistor is applied on J2 does it become necessary to install a shunt across JP3, and at the same time, Bits 6, 7, 8 on the DIP switch all need to be turned off.

JP4 - Selects USB modes: a shunt across IREF and V2P8 will set USB 500mA mode, a shunt across IREF, and GND will set USB 100mA mode. When the charge current is programmed by the resistors connected to the IREF pin, no shunt should be installed on JP4.

Functional Description

The ISL78693 is an integrated charger for single-cell Lithium chemistry batteries. The ISL78693 functions as a traditional linear charger when powered with a voltage source adapter. When powered with a current-limited adapter, the charger minimizes the thermal dissipation commonly seen in traditional linear chargers. As a linear charger, the ISL78693 charges a battery in the popular Constant Current (CC) and Constant Voltage (CV) profile. The constant charge current I_{REF} is programmable up to 1A with an external resistor or a logic input. The charge voltage V_{CH} has 1% accuracy over the entire recommended operating condition range. The charger preconditions the battery with a 10% typical of the programmed current at the beginning of a charge cycle until the battery voltage is verified to be above the minimum fast charge voltage, $V_{TRICKLE}$. This low current preconditioning charge mode is named Trickle mode. The verification takes 15 cycles of an internal oscillator whose period is programmable with a timing capacitor on the time pin. A thermal-foldback feature protects the device from the thermal concern typically seen in linear chargers. The charger reduces the charge current automatically as the IC internal temperature rises above +100°C to prevent further temperature rise. The thermal-foldback feature guarantees safe operation when the Printed Circuit Board (PCB) is space limited for thermal dissipation.

A TEMP pin monitors the battery temperature to ensure a safe charging temperature range. The temperature range is programmable with an external negative temperature coefficient (NTC) thermistor. The TEMP pin is also used to detect the removal of the battery. The charger offers a safety timer for setting the fast charge time (TIMEOUT) limit to prevent charging a dead battery for an extensively long time. The Trickle mode is limited to 1/8 of TIMEOUT.

The charger automatically recharges the battery when the battery voltage drops below a recharge threshold of 3.3V (typical). When the input supply is not present, the ISL78693 draws less than 1µA current from the battery. Three indication pins are available from the charger to indicate the charge status. The V2P8 outputs a 2.8VDC voltage when the input voltage is above the Power-On Reset (POR) level and can be used as the power-present indication. This pin is capable of sourcing a 2mA current, so it can also be used to bias external circuits. The STATUS pin is an open-drain logic output that turns LOW at the beginning of a charge cycle until the End-of-Charge (EOC) condition is qualified. The EOC condition is when the battery voltage rises above the recharge threshold and the charge current falls below a preset of a tenth of the programmed charge current. Once the EOC condition is qualified, the STATUS output rises to HIGH and is latched. The latch is released at the beginning of a charge or recharge cycle. The open-drain FAULT pin turns low when any fault conditions occur. The fault conditions include the external battery temperature fault, a charge time fault, or the battery removal.

PCB Layout Recommendations

The ISL78693 internal thermal foldback function limits the charge current when the internal temperature reaches approximately +100°C. In order to maximize the current capability, it is very important that the exposed pad under the package is properly soldered to the board and is connected to other layers through thermal vias. More thermal vias and more copper attached to the exposed pad usually result in better thermal performance. On the other hand, the number of vias is limited by the size of the pad. The 3x3 DFN package allows nine vias to be placed in three rows. Since the pins on the 3x3 DFN package are on only two sides, as much top layer copper as possible should be connected to the exposed pad to minimize the thermal impedance. Refer to [“PCB Layout”](#) starting on [page 7](#).

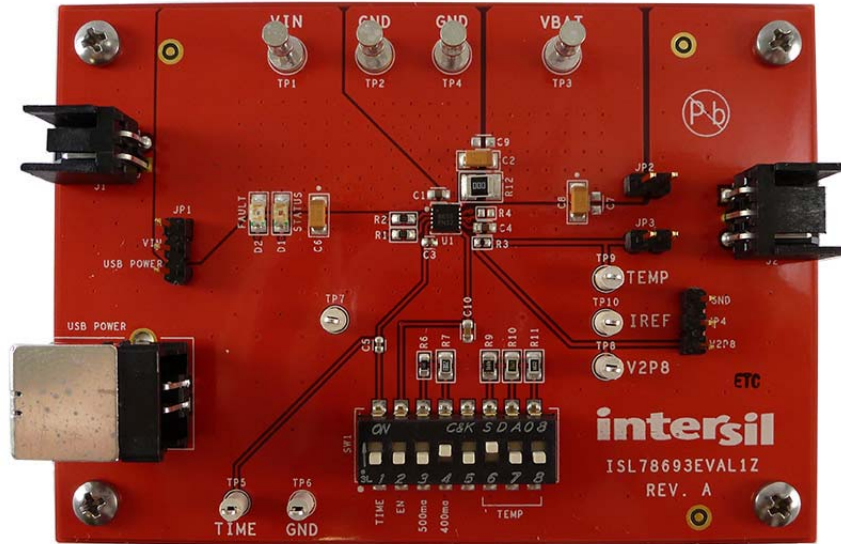

FIGURE 3. TOP VIEW

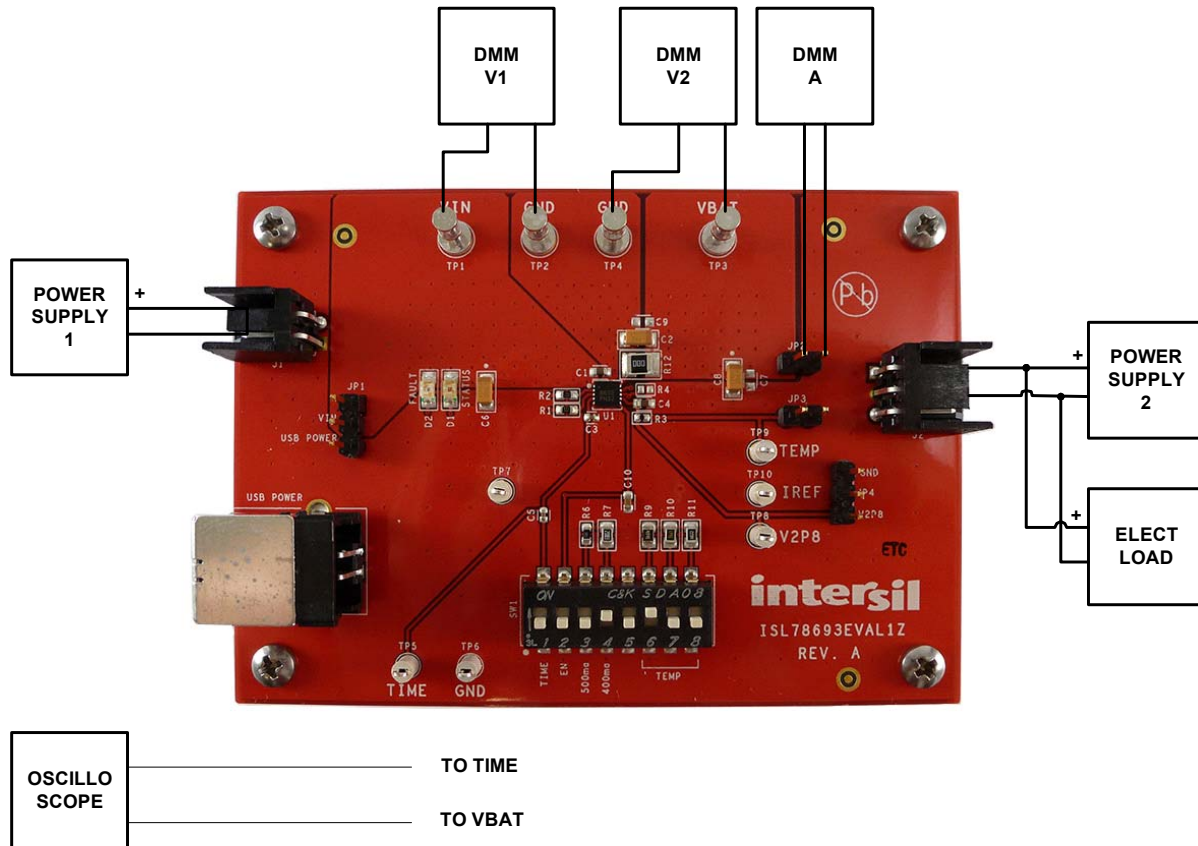

FIGURE 4. CONNECTION OF INSTRUMENTS

Schematic

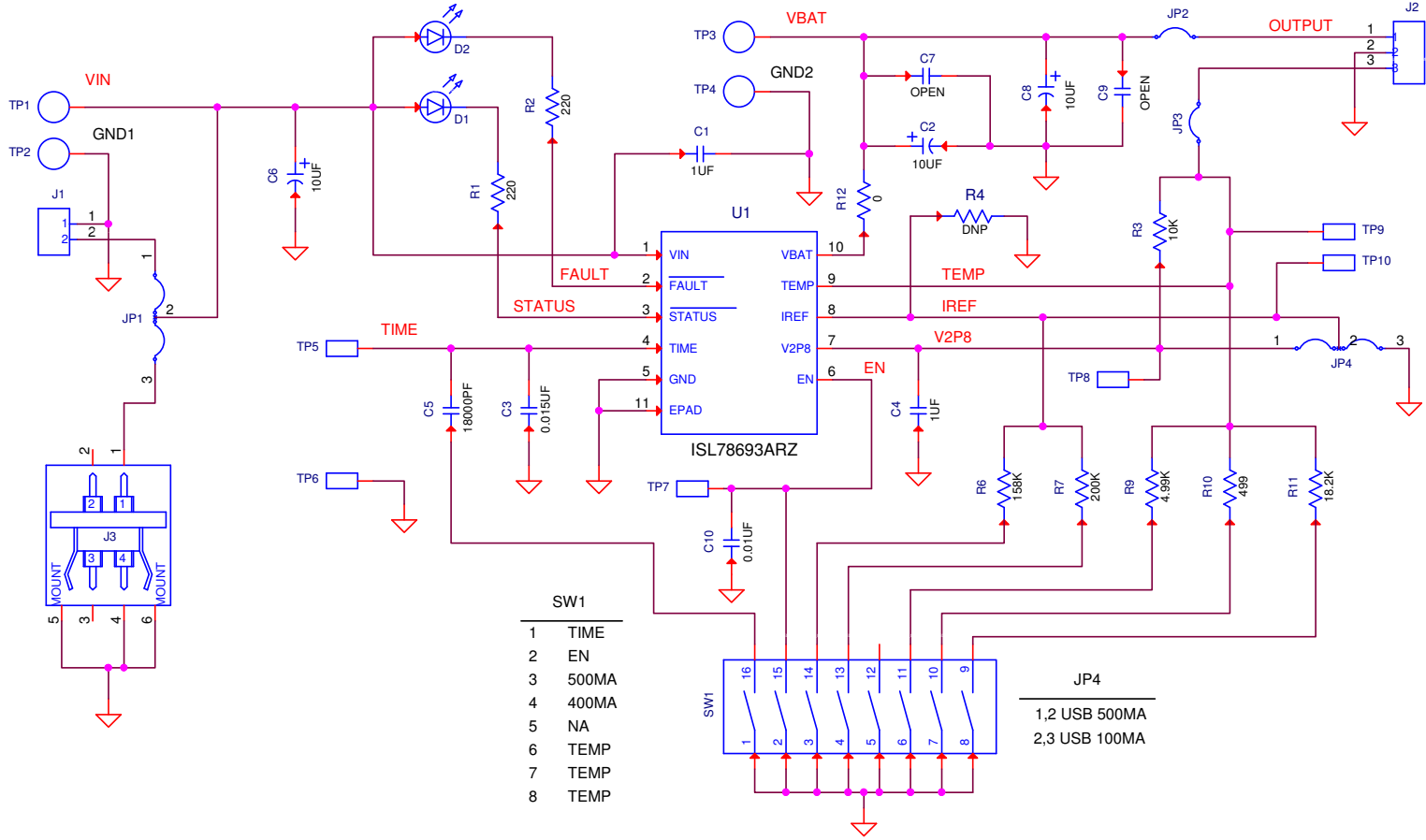

FIGURE 5. ISL78693EVAL1Z SCHEMATIC

SW1	
1	TIME
2	EN
3	500MA
4	400MA
5	NA
6	TEMP
7	TEMP
8	TEMP

JP4	
1,2	USB 500MA
2,3	USB 100MA

User Guide 098

Bill of Materials

QTY	UNITS	REFERENCE DESIGNATOR	DESCRIPTION	MANUFACTURER	MANUFACTURER PART NUMBER
1	ea		PWB-PCB, ISL78693EVAL1Z, REVA, ROHS		ISL78693EVAL1ZREVAPCB
2	ea	C1, C4	CAP, SMD, 0603, 1.0µF, 16V, 10%, X7R, ROHS	TDK	C1608X7R1C105K
1	ea	C3	CAP, SMD, 0402, 0.015µF, 16V, 10%, X7R, ROHS	PANASONIC	ECJ-0EB1C153K
1	ea	C5	CAP, SMD, 0402, 0.018µF, 16V, 10%, X7R, ROHS	MURATA	GRM155R71C183KA01D
1	ea	C10	CAP, SMD, 0603, 0.01µF, 16V, 10%, X7R, ROHS	VENKEL	C0603X7R160-103KNE
0	ea	C7, C9	CAP, SMD, 0603, DNP-PLACE HOLDER, ROHS		
3	ea	C2, C6, C8	CAP-TANT, LOW ESR, SMD, A, 10µF, 16V, 20%, 200mΩ, ROHS	AVX	TCJA106M016R0200
4	ea	TP1-TP4	CONN-TURRET, TERMINAL POST, TH, ROHS	KEYSTONE	1514-2
1	ea	J1	CONN-HEADER, 2P, SHROUDED, 2.54mm, RT. ANGLE, ROHS	AMP/TYCO	2-644803-2
1	ea	J2	CONN-HEADER, 3P, SHROUDED, 2.54mm, RT. ANGLE, ROHS	AMP/TYCO	2-644803-3
1	ea	J3	CONN-TYPE B RECEPTACLE, TH, 4 POS, RT. ANGLE, ROHS	AMP/TYCO	292304-1
6	ea	TP5-TP10	CONN-MINI TEST POINT, VERTICAL, WHITE, ROHS	KEYSTONE	5002
2	ea	JP1, JP4	CONN-HEADER, 1x3, BREAKAWY 1x36, 2.54mm, ROHS	BERG/FCI	68000-236HLF
2	ea	JP2, JP3	CONN-HEADER, 1x2, RETENTIVE, 2.54mm, 0.230x0.120, ROHS	BERG/FCI	69190-202HLF
1	ea	D2	LED, SMD, 1206, RED, 30mA, 60mW, 17mcd, ROHS	DIALIGHT	597-3111-407F
1	ea	D1	LED, SMD, 1206, GREEN, 75mW, 3mcd, Pb-Free	DIALIGHT	597-3311-407F
1	ea	U1	IC-4.1V LI-ION/LI POLYMER CHARGER, 10LD DFN 3x3, ROHS	INTERSIL	ISL78693ARZ
1	ea	R3	RES, SMD, 0402, 10k, 1/16W, 1%, TF, ROHS	PANASONIC	ERJ-2RKF1002X
0	ea	R4	RES, SMD, 0402, DNP, DNP, DNP, TF, ROHS		
2	ea	R1, R2	RES, SMD, 0603, 220Ω, 1/10W, 1%, TF, ROHS	YAGEO	9C06031A2200FKHFT
1	ea	R6	RES, SMD, 0805, 158k, 1/8W, 1%, TF, ROHS	YAGEO	RC0805FR-07158KL
1	ea	R11	RES, SMD, 0805, 18.2k, 1/10W, 1%, TF, ROHS	PANASONIC	ERJ-6ENF1822V
1	ea	R7	RES, SMD, 0805, 200k, 1/8W, 1%, TF, ROHS	VENKEL	CR0805-8W-2003FT
1	ea	R10	RES, SMD, 0805, 499Ω, 1/8W, 1%, TF, ROHS	YAGEO	RC0805FR-07499RL
1	ea	R9	RES, SMD, 0805, 4.99k, 1/8W, 1%, TF, ROHS	PANASONIC	ERJ-6ENF4991V
1	ea	R12	RES, SMD, 1206 0Ω, 1/4W, 1%, TF, ROHS	PANASONIC	ERJ-8GEY0R00V
1	ea	SW1	SWITCH-DIP, SMD, 8POS, TOP SLIDE, SPST, 24V, ROHS	C&K COMPONENTS	SDA08H1SBD
4	ea	Four corners	SCREW, 4-40X1/4in, PAN, SS, PHILLIPS		
4	ea	Four corners	STANDOFF, 4-40X3/4in, F/F, HEX, ALUMINUM, ROHS	KEYSTONE	2204 (.250 OD)

PCB Layout

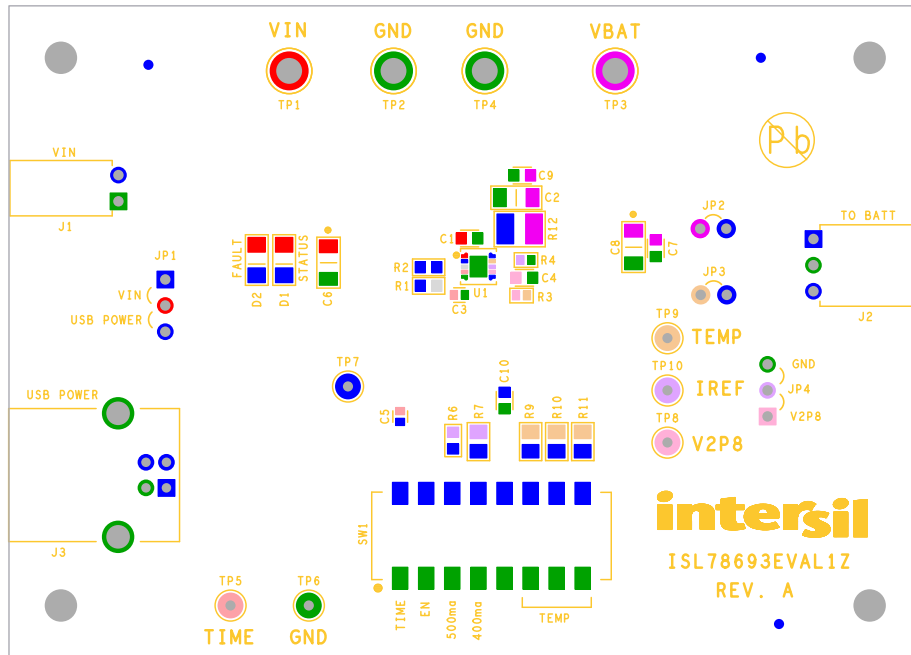

FIGURE 6. SILK LAYER TOP

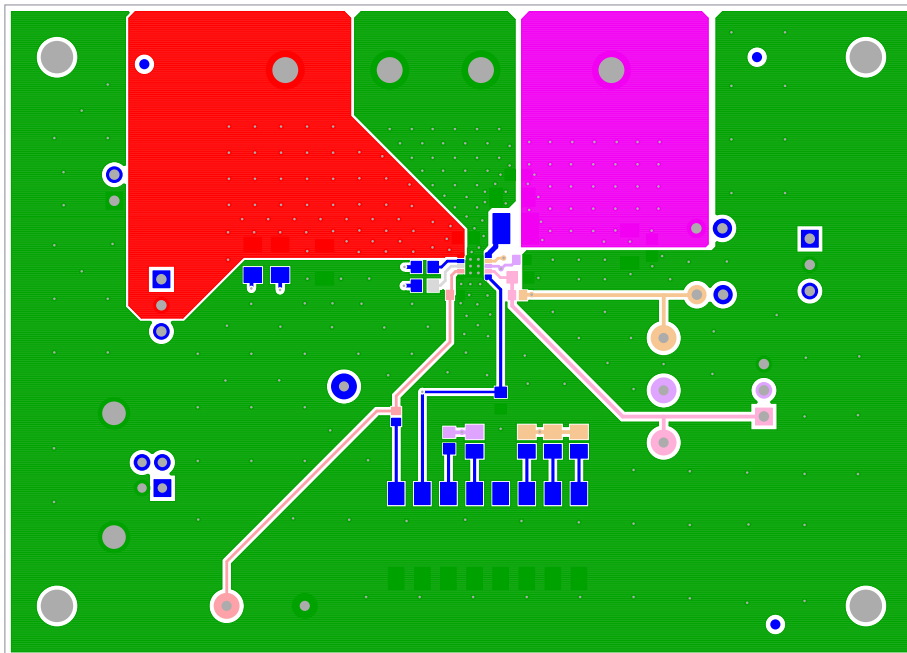

FIGURE 7. TOP LAYER COMPONENT SIDE

PCB Layout (Continued)

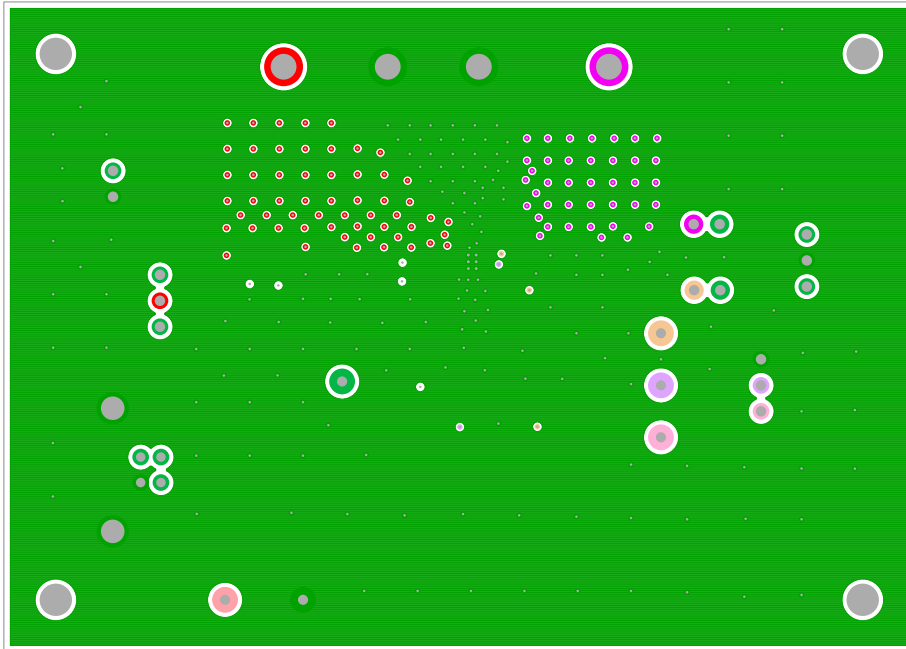

FIGURE 8. INTERNAL (LAYER 2)

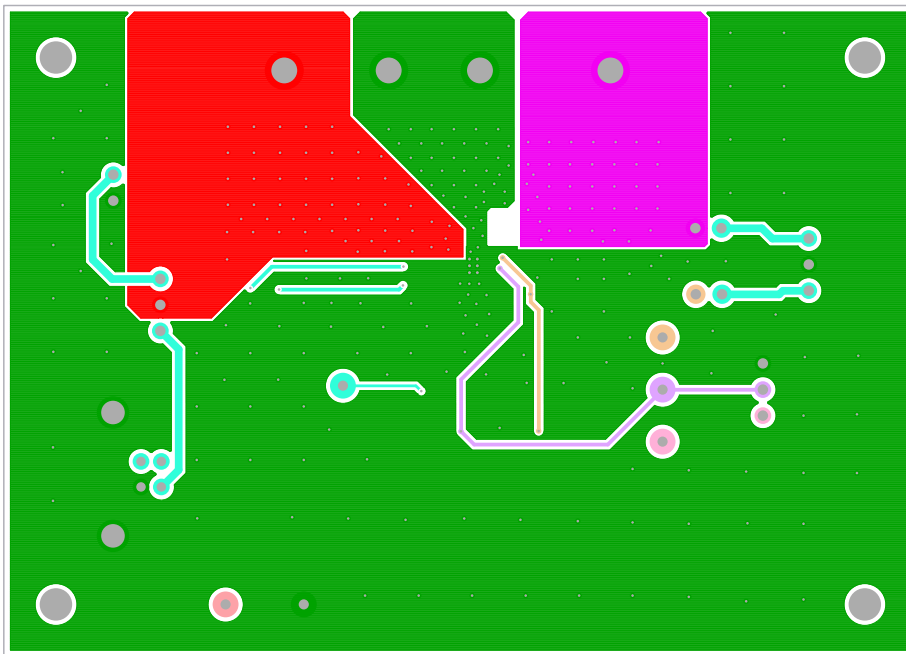

FIGURE 9. INTERNAL (LAYER 3)

PCB Layout (Continued)

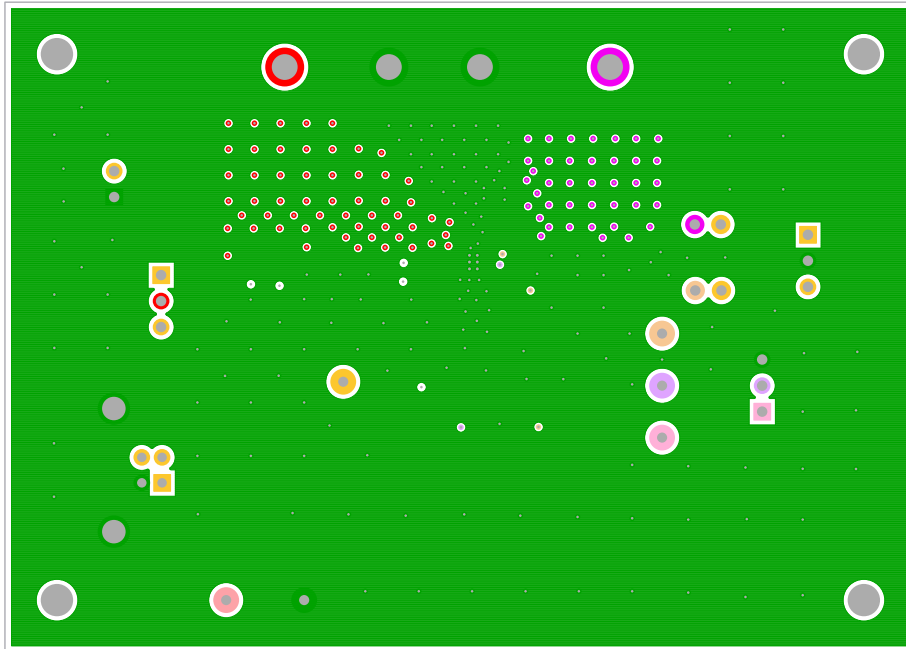

FIGURE 10. BOTTOM LAYER SOLDER SIDE

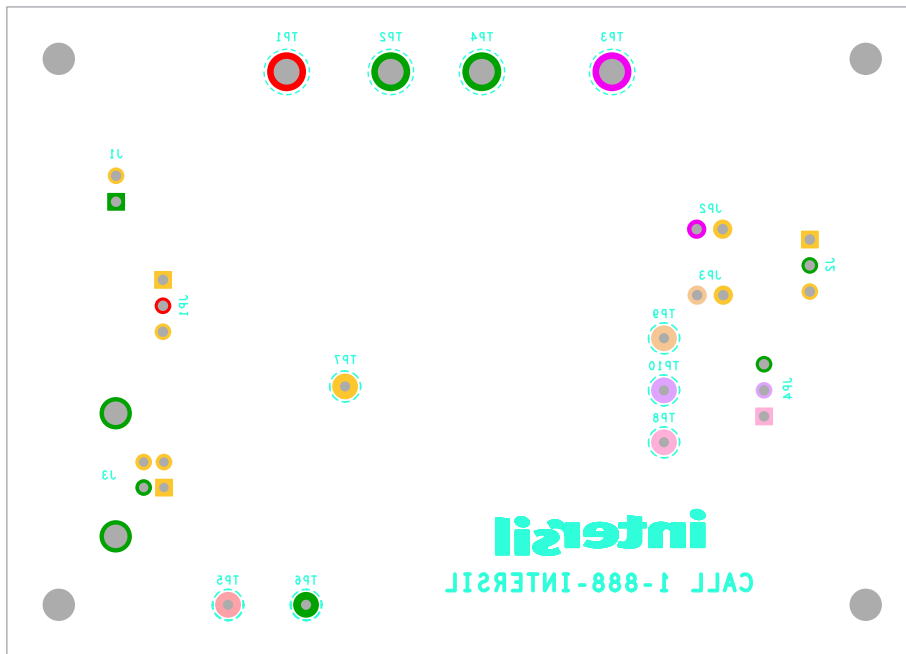

FIGURE 11. SILKSCREEN BOTTOM (TOP VIEW)

Typical Performance Curves

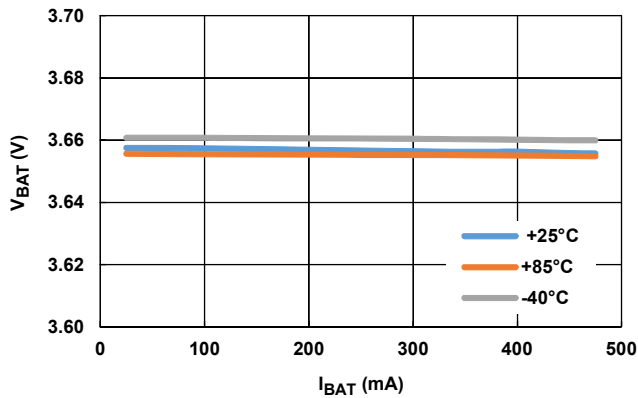

FIGURE 12. VOLTAGE REGULATION vs CHARGE CURRENT

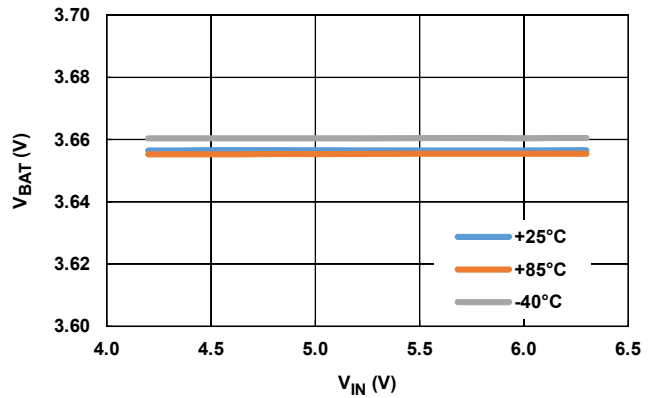

FIGURE 13. NO LOAD VOLTAGE vs TEMPERATURE

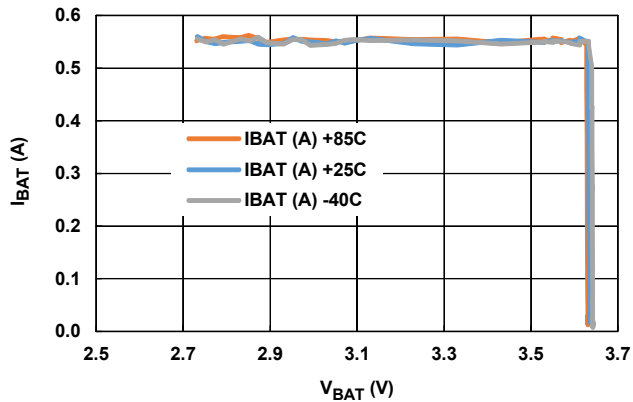

FIGURE 14. CHARGE CURRENT vs OUTPUT VOLTAGE, $R_{REF} = 158k$

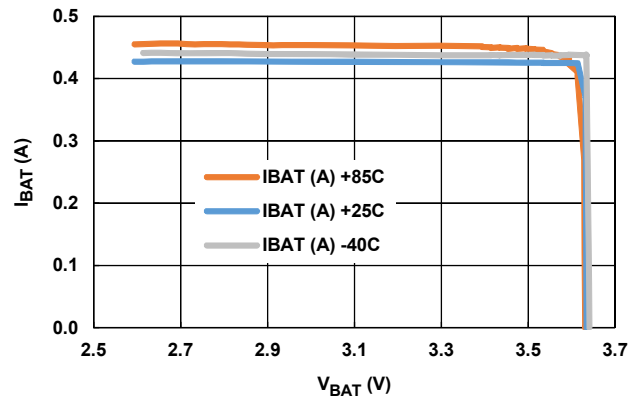

FIGURE 15. CHARGE CURRENT vs OUTPUT VOLTAGE, $R_{REF} = 200k$

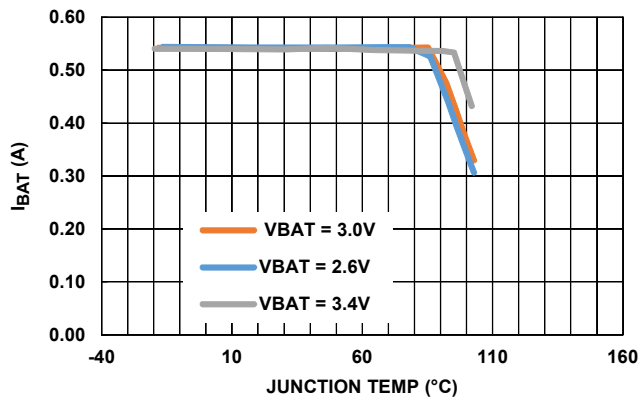

FIGURE 16. CHARGE CURRENT vs JUNCTION TEMPERATURE, $R_{REF} = 158k$

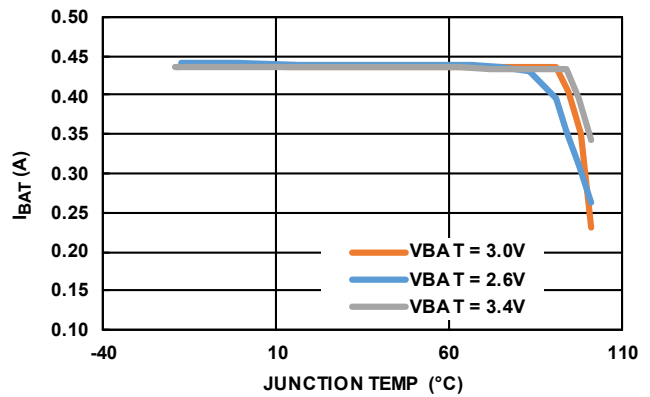

FIGURE 17. CHARGE CURRENT vs JUNCTION TEMPERATURE, $R_{REF} = 200k$

Typical Performance Curves

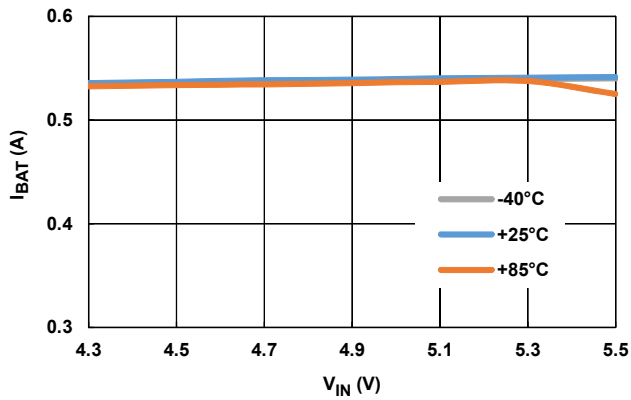

FIGURE 18. CHARGE CURRENT vs INPUT VOLTAGE, $V_{BAT} = 3V$, $R_{IREF} = 158k$

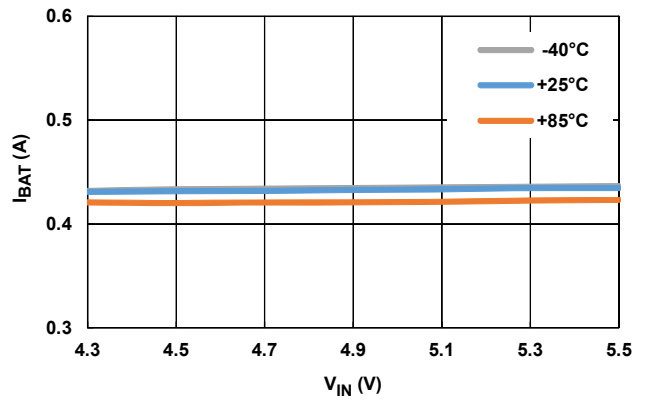

FIGURE 19. CHARGE CURRENT vs INPUT VOLTAGE, $V_{BAT} = 3V$, $R_{IREF} = 200k$

Intersil Corporation reserves the right to make changes in circuit design, software and/or specifications at any time without notice. Accordingly, the reader is cautioned to verify that the document is current before proceeding.

For information regarding Intersil Corporation and its products, see www.intersil.com