

SWIFT 2 Racing drone

User Manual

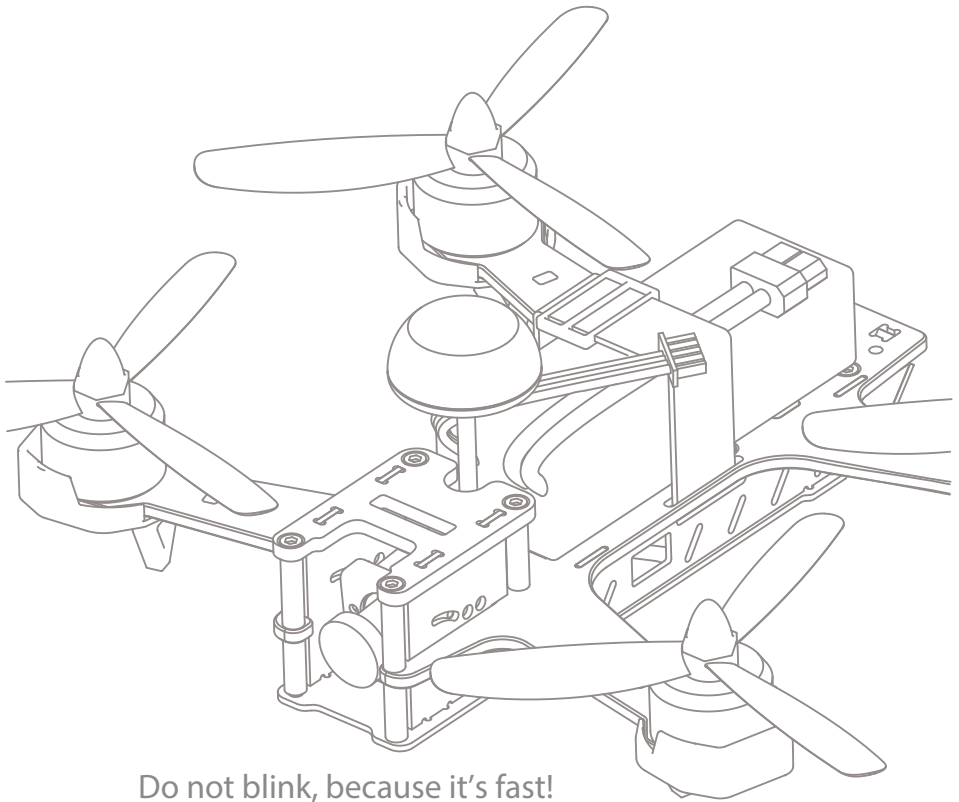

Do not blink, because it's fast!

SwellPro

www.swellpro.com

INDEX

1. Getting to know your aircraft.....	3
2. Getting to know your remote controller	4
3. Specifications	6
4. Important – Before you fly !.....	8
5. Charging the battery.....	8
6. Preparing the drone	9
7. Ready for flight	11
8. Operating Instructions	13
9. At the end of the flight.....	16
10. Additional Instructions	17
11. Balance Charger – Instructions for use.....	24
12. Installation of Camera Mount.....	27

Introducing the SWIFT 2 Racing drone

A professional, compact and aggressive, ready to fly, and yet elegant racing drone.

Do not blink, because it's fast!

The Drone:

- Superior modular and highly integrated design.
- Championship level racing power system.
- Compatible with different types of blades.
- 3S 2600 mAh LiPo battery (can be used with 4S batteries for overhaul greater performance)
- 120° wide angle FPV camera lens.
- 800TVL/F2.5 aperture.
- Rugged construction, with anti drop ability
- Professionally designed, offering maximum protection.
- Easy to maintain and repair, suitable for the DIY enthusiast, or professional.
- 5.8G real time video transmitter.
- 5.8G clover antenna. – which is quick and easy to change.
- Top Quality ESC's , which enhances power and reduces maintenance.

The controller:

- User friendly Radio Controller, providing you with comprehensive information.
- Built in Buzzer – which helps to locate the drone, quickly and easily.
- Three flight modes, catering for the all pilots, from the least experienced to the most senior.
- Comes with elegant and adjustable flight indicator lights, at the rear, which can be turned ON/OFF on the radio controller.
- On Screen Data (OSD) on the controller can be turned On or Off . The Pilot information Display parameters can easily be customized to suit individual requirements.
- Lock/unlock the motor by switch. This is very convenient and protects the drone and prevents accidents.
- Compact package design.

1. Getting to know your Aircraft

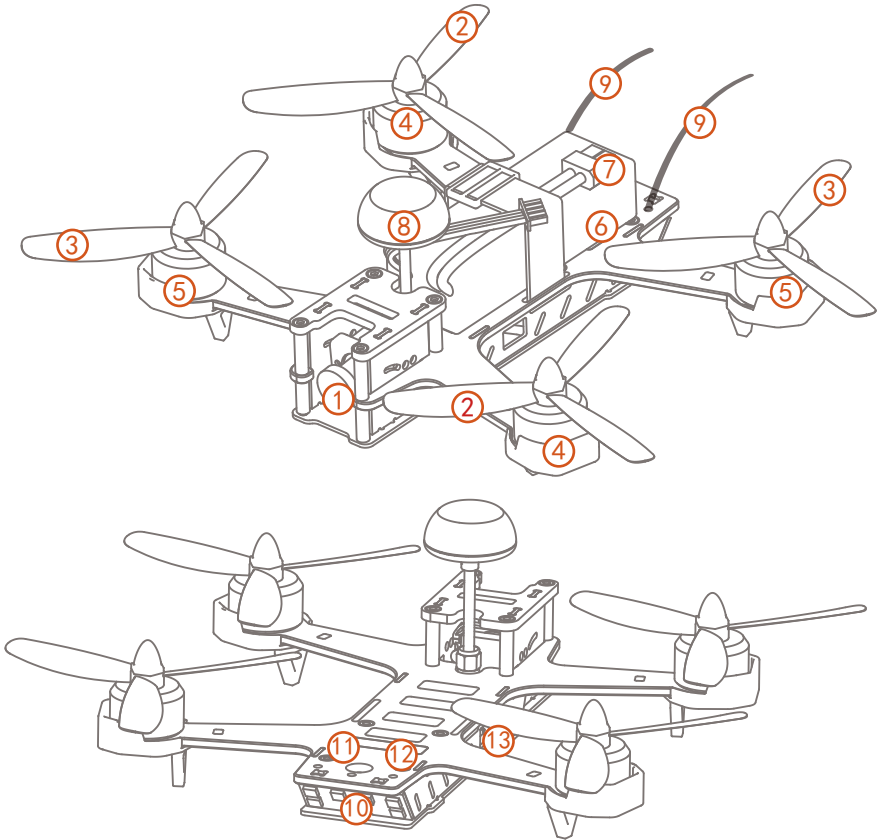

- | | |
|---------------------------|------------------------------------|
| 1. Camera | 8. Mushroom antenna |
| 2. Propeller(CW) | 9. Receiver antennas |
| 3. Propeller(CCW) | 10. Indicator lights – on the tail |
| 4. Clockwise motor | 11. Transmitter monitor |
| 5. Counterclockwise motor | 12. Transmitter control switch |
| 6. Li-Po Battery | 13. USB Ports |
| 7. Power connector | |

2. Getting to know your remote controller

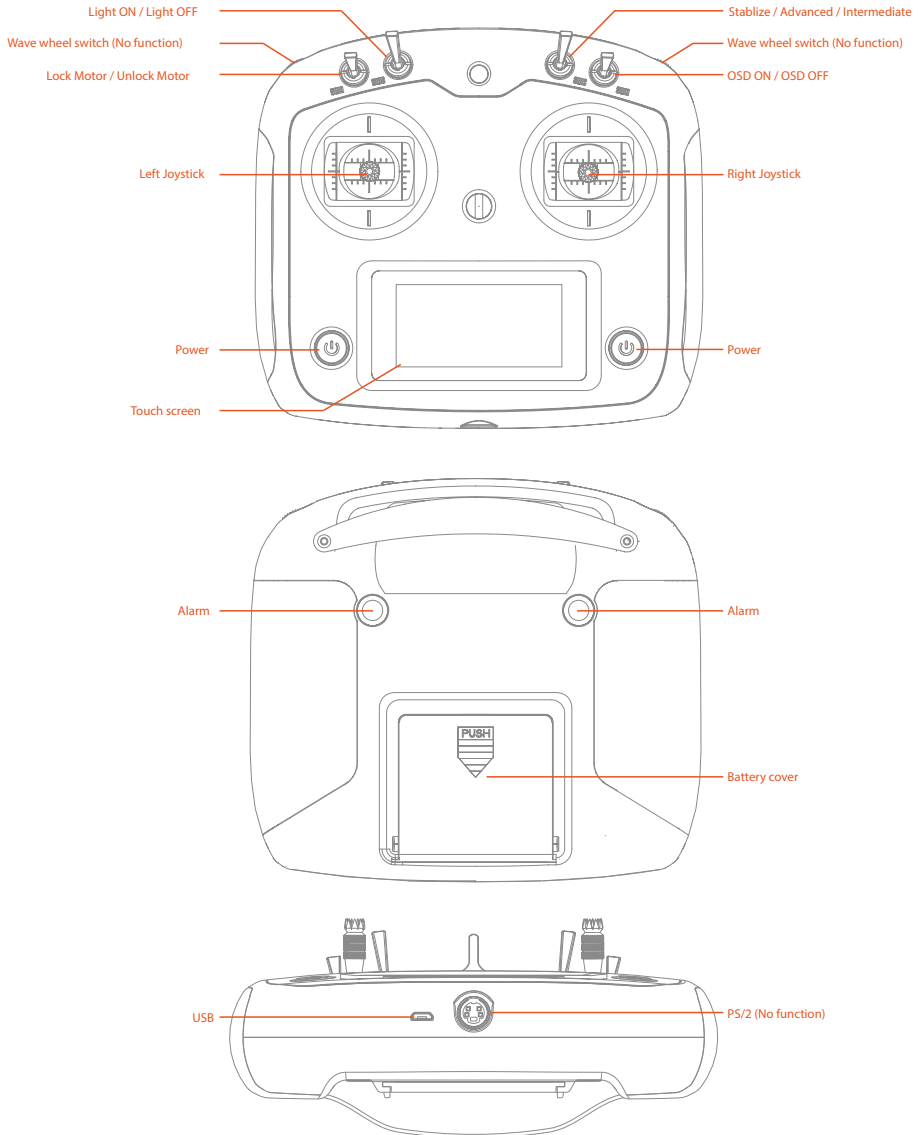

Please Note: The factory default setting of the remote controller is the left hand setting. The controller can be configured in the right hand setting.

Please make a note of your requirements to enable customization of your controller.

The Swift 2 system offers 3 useful flight modes,

STABILIZE Flight Mode

INTERMEDIATE Flight Mode

ADVANCED(RATE) Flight Mode

Flight modes are selected by SWC.(Please select the appropriate mode according to your flight skills)

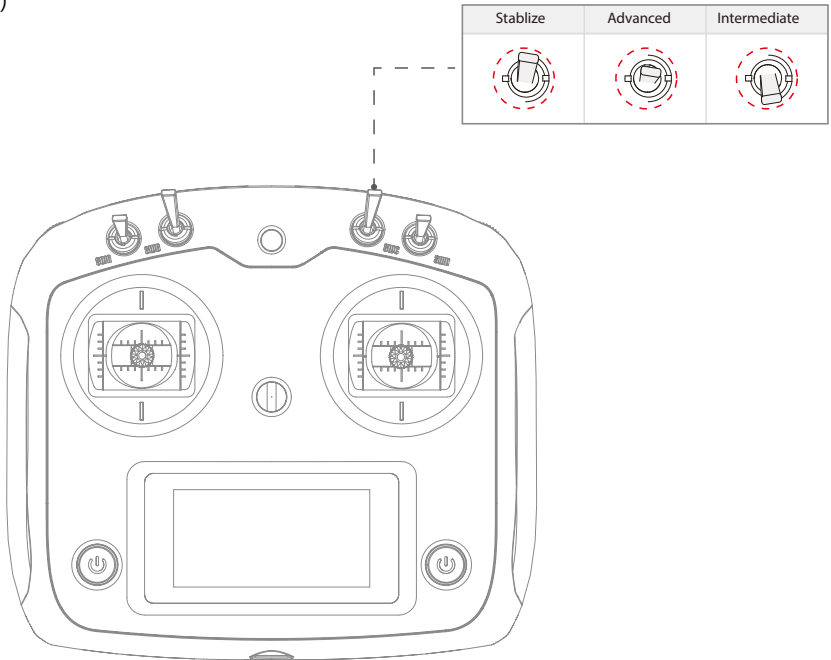

STABILIZE Flight mode: in this mode , the Swift's operation is relatively stable, it can not roll, it is recommended for beginners.

INTERMEDIATE flight mode: in this mode , the Swift's operation is with partial stabilization function, it's operation is relatively flexible, and it can roll.

ADVANCED Flight Mode: in this mode , the Swift's operation is without stabilization function, it's operation is very flexible, it can roll.

Please Note: The different flight modes are set using the main flight controller

3. Specifications

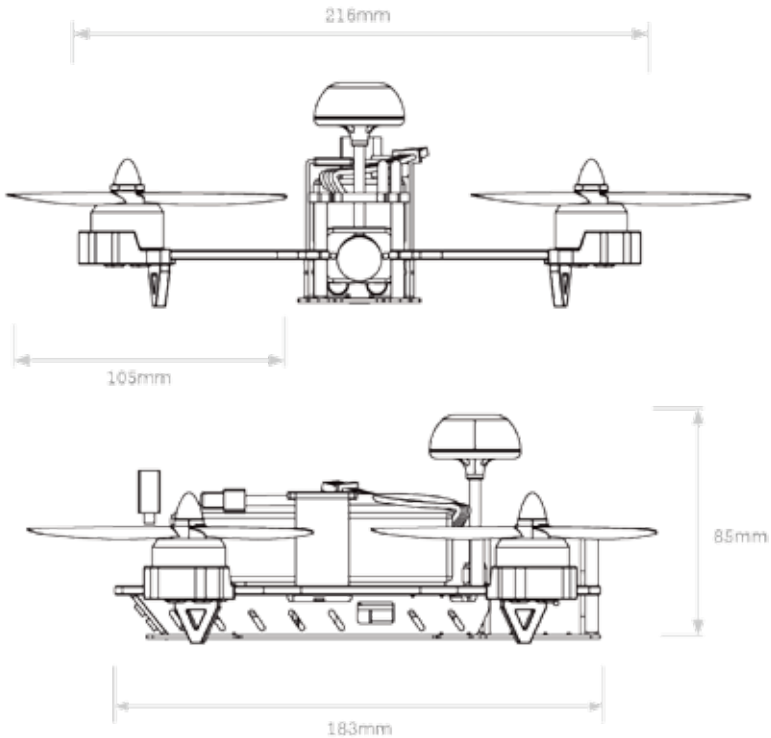

Main carbon frame: 3.5mm 3K ultra strong carbon fibre frame

Aircraft

Propeller: #5045 3 Blades

Axis Diameter: 220mm

Overall Dimensions (L x W x H): 183 x 216 x 85mm

Weight: 378g (Battery excluded)

Brushless Motor: #2205 2300KV

Brushless ESC: 25A

Battery: 3S 2600 mAh LiPo (Weight: 214g)

Transmitter: 5.8G 40CH, Digital Channel Selector

Flight Time: 12~15 mins (2600mAh)

Max Flight Speed: 150km/h

Max Flight Distance: 1000m

Operating Temperature: -10C°~ 40C°

Flight Controller: F3 enhanced version

OSD: Integrated

Remote Controller

Net Weight: 435g (Battery Excluded)

Frequency Channel: 2405 ~ 2475MHz

Remote Control Distance: 1.0 KM

Receiver Sensitivity (1%PER) : -105dbm

Working Current: 120 mA

Battery Operating Voltage: 7.4V-11.1V

Channels: 10

Camera

Horizontal Resolution: 800TVL

Video Options: PAL/NTSC

Power input: 5V

FOV: 120 Degree

Aperture: F2.5

Transmitter

Transmitter: 5.8G Wireless Image Transmission

Channels: 40CH

Power Output: 25mW, 200mW, 400mW

4. Attention: before your intended flight...

- The Swift is recommended for pilots, 15 years or older, with some RC hobby experience.
- Only fly the Swift in dry weather, with low wind.
- Please do not fly in rain or heavy foggy conditions.
- Always choose large open fields for flying.
- Please Check local laws and regulations governing the use of drones and for legal flying areas.
- Always keep at least 10 feet distance to the aircraft, to avoid injury from high-speed propellers on the ground, or while flying.
- Do not fly close to high-voltage power lines, cellphone towers, or radio towers, as these may disrupt your control signal.
- NEVER fly over crowds, concerts or sports stadiums.

5. Charge the battery

Connect the power-cable to the wall-outlet, the E3 charger can connect to a supply voltage from 100v to 240v .

When correctly powered, the charger LED will be flashing green.

Insert the LiPo battery balance plug into the E3 charger.

During charging the LED will be flashing green and display power.

When charging is completed, the charger will display a solid BLUE LED.

Attention:

1. When the 4 LED lights flashes at the same time, there maybe something wrong with charger or battery, so please stop charging.
2. Please refer to Page 24 for details of the E3 Balance Charger.

6. Preparation of the drone for flight.

First, install the mushroom antenna to the mounting brackets as shown.

Next, push the assembled mushroom antenna into the Video Transmitter.

Finally tighten the rotating collar with the supplied wrench.

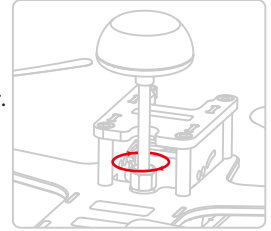

Installation of the propellers

Fix the clockwise propeller onto the clockwise motor according to the direction of blue arrow.

Fix the counter clockwise propeller onto the counterclockwise motor according to the direction of orange arrow.

Tighten the propellers manually making sure the propellers are installed in proper way, and securely fastened.

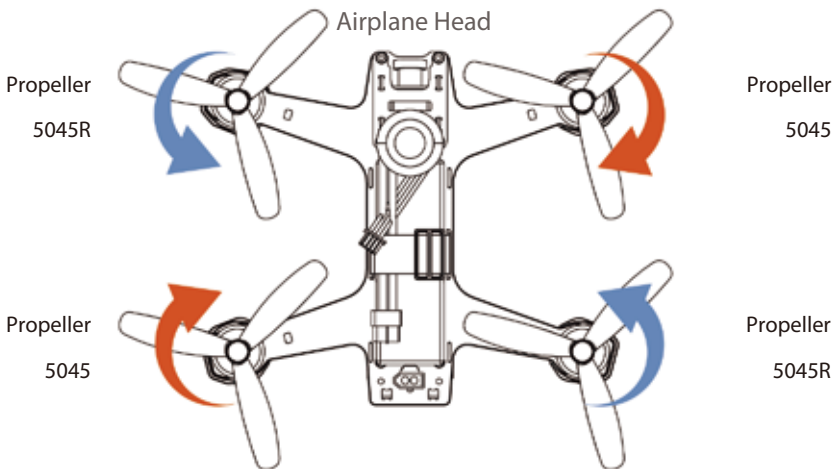

Attention:

Install prop by hand, tighten by with the included wrench, whilst holding the motor.

You can also use the wrench to help remove broken props in the event of damage, or in the event of a crash.

Battery installation

First insert the battery anti-slip mat into the battery compartment. Put the battery on top of the anti-slip mat.

Move the battery forward-backwards as required to establish perfect balance, then firmly secure the battery with the velcro strap. Please read

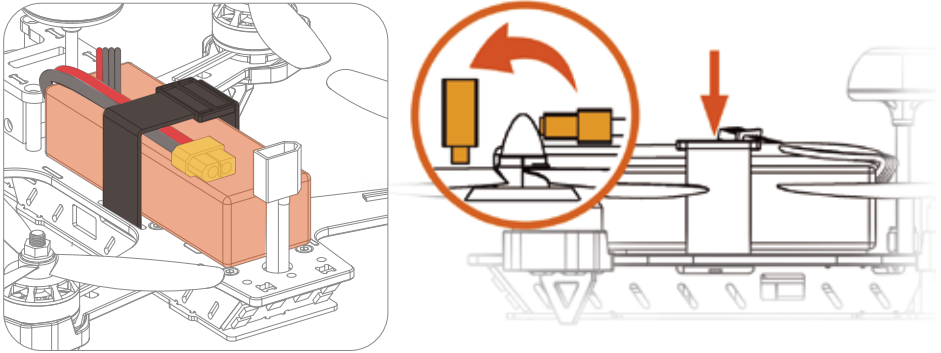

Fit & fasten battery with velcro

Centre of Gravity adjustment

Hold the Swift by the COG line (center of gravity). See the illustration above for the COG

Re-position the battery forward-backwards, until the quad balances.

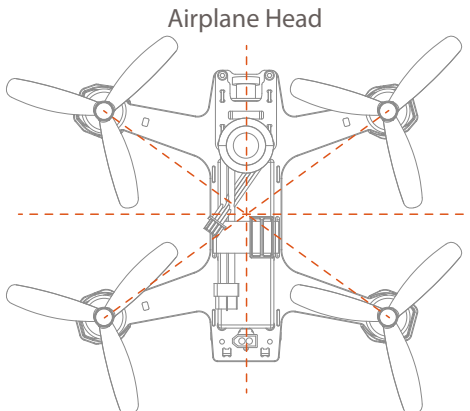

7. Ready for flight

1. Place the aircraft in a wide open space, with the rear facing you.
2. Please ensure that video receiving equipment is setup and ready for use, displaying an image and OSD information.
3. When all is setup, prepare for take off, and flight.

Please consider the points mentioned below:

Attention:

- Put the motor switch to the lock mode position, move the throttle to the lowest position.
- When voltage reaches below 10.8 volts, the rear LED lights will flash quickly and the beeper will sound an alarm.
- Please prepare to land, without hesitation when you hear the alarm, or see the OSD indicating 10.8 volts or less.

7.1 Binding the drone with the controller

To bind the controller with the Swift, press the two power on buttons simultaneously to turn the controller on.

Put the aircraft on a horizontal place and connect the aircraft power.

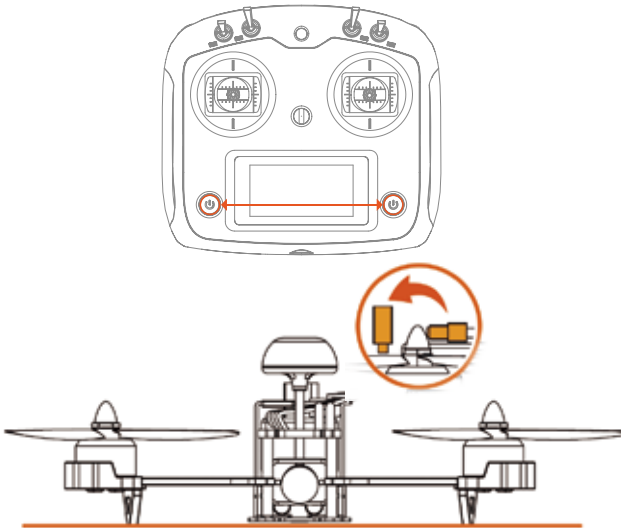

7.2 Motor unlock

Place the throttle joystick at the lowest position.

Move switch SWA to it's lowest position to unlock the motors.

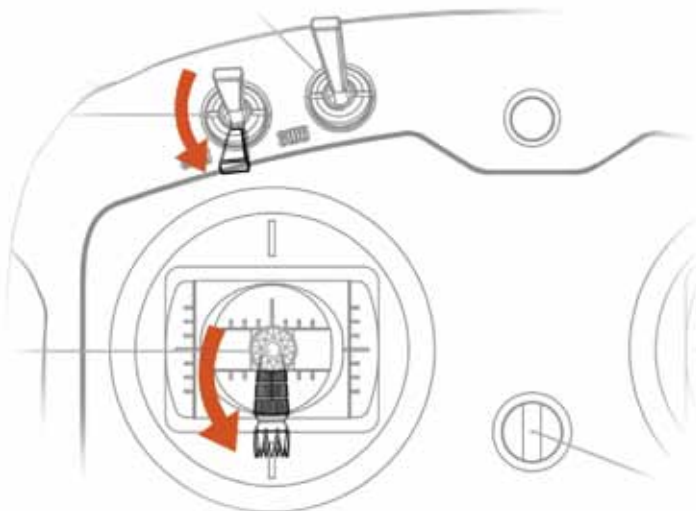

8. Operation instructions

Aircraft Reaction

( the direction of the head)

Remote Controller Instructions

Throttle

up/down

(The rear toward operator)

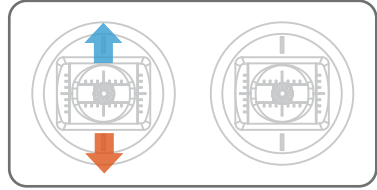
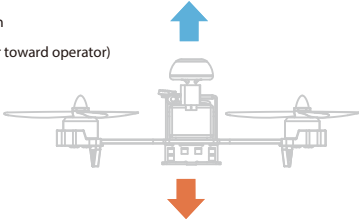

Pitch

forward/backward

(Indicator light instruction)

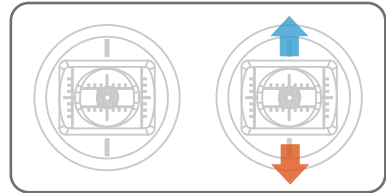
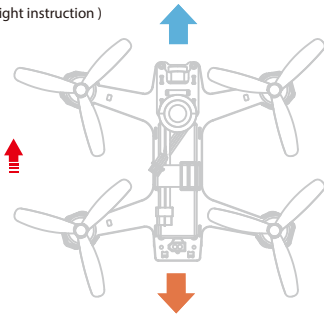

ROLL (lean)

left/right

(Indicator light instruction)

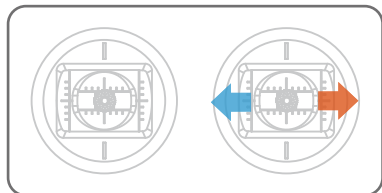
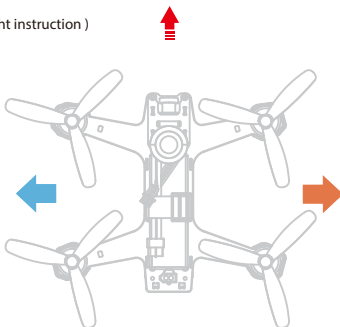

Aircraft Reaction

(← the direction of the head)

Remote Controller Instructions

YAW(turn)

left/right

(Indicator light instruction)

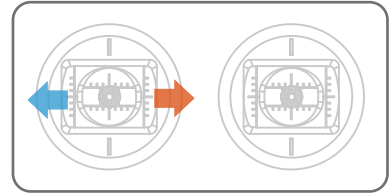
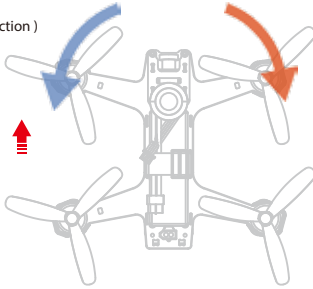

The aircraft roll forward

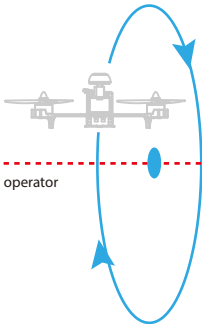

The rear toward operator

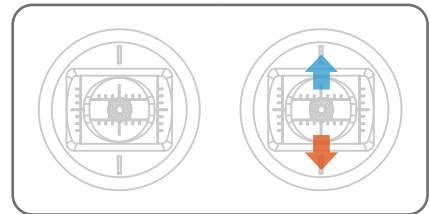
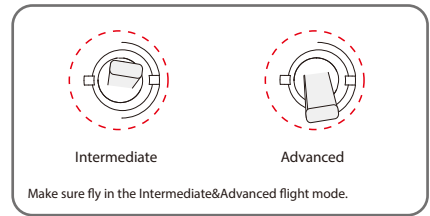

The aircraft roll backward

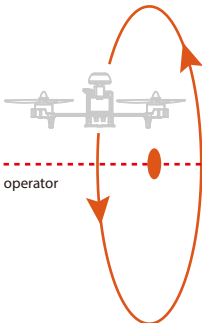

The rear toward operator

Attention:

Always select large open spaces with soft ground for flying.

Rolls and flips are best suited for experienced pilots.

Match throttle power whilst in flight to manage the altitude.

The aircraft roll left

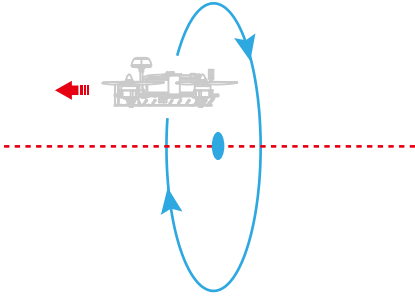

The aircraft roll right

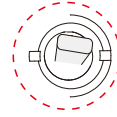
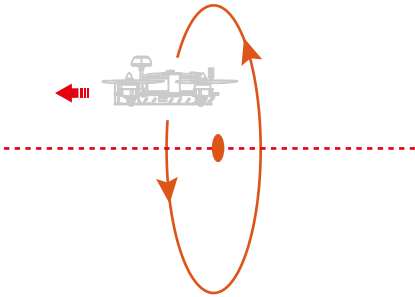

Intermediate

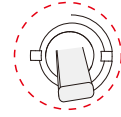

Advanced

Make sure fly in the Intermediate&Advanced flight mode.

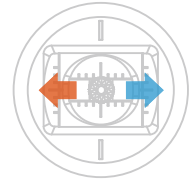
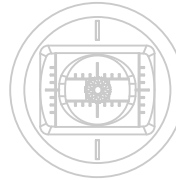

Attention:

Always select large open spaces with soft ground for flying.

Rolls and flips are best suited for experienced pilots.

Match throttle power whilst in flight to manage the altitude.

Obstacle flying



Attention:

Obstacle flying is more suitable for experienced pilots.

Recommended FPV range 300m (depending on the local environment).

Avoid flying over people, animals or high voltage lines.

9. Ending the flight

Land the aircraft

Lock the motors

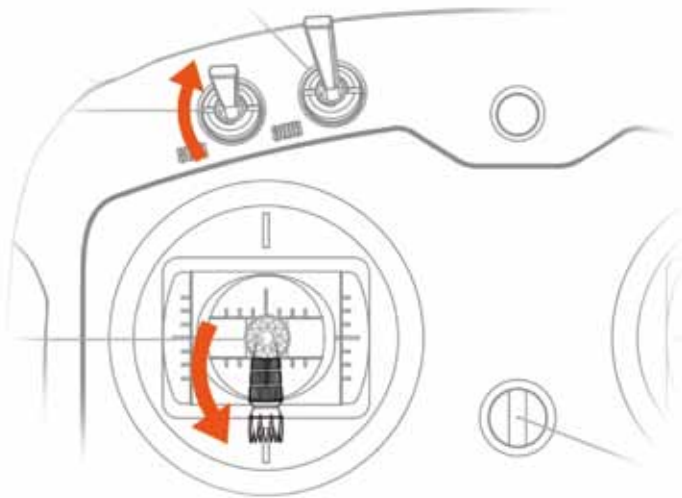

First Power off the aircraft, then turn off the radio.

Finally, remove the battery from the aircraft.

Please Note:

1. After 5 minutes without any operation, the indicator lights will flash and the motors will sound an alarm, to remind you of the powering off the motors.
2. If the aircraft goes down in some areas that are not easy to find, you can hold the alarm button, resulting in the buzzer sounding on the drone, to assist you in finding it.

10. Additional Instructions

10.1 Remote controller settings

Attention: We strongly recommend that the default settings of remote controller are not changed. These setting changes are intended for senior pilots.

Boot screen(Main interface)

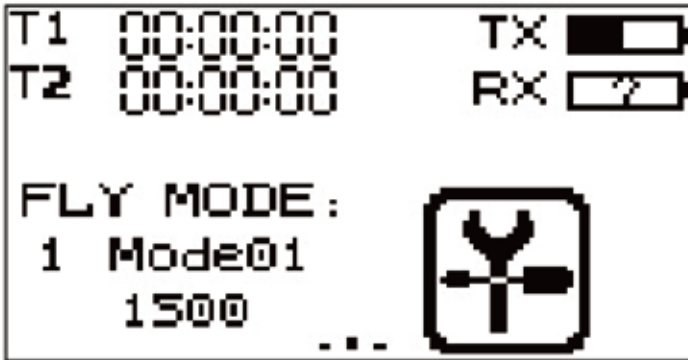

T1 \T2: Timer and setting menu

FLY MODE: Current flight mode and setting menu

TX/RX: Status and voltage settings menu

Display actuator

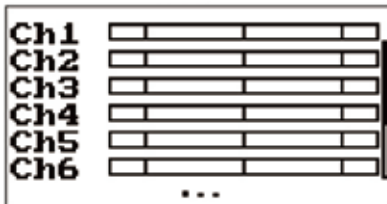

Name	ID	Value

Slide the acutators up and/or down to adjust, long press to check the position or status.

Caution: Power off the throttle to avoid damage and personnel injuries before checking the actuator.

Main interface display.

Making operation more easier and simple

- Sliding the screen to the right to check the channel status, Slide the screen to the left to check the sensor list.
- Click the wrench icon to enter the main menu.
- Slide the screen down to view the settings menu.
- Touch the function name to enter the function setting menu.
- Slide the screen up and down to skim the function menu, and select a menu item in the list to enter the settings menu.
- Click the return icon to return to the previous menu.

Positive reversal

The reverse function changes a channels direction of movement in relation to its input.

For example: If the blades are spinning in the wrong direction, pushing the Swift towards the ground instead of taking off, this function can be used to correct this.

	← REVERSE			
Ch1	Nor	Ch2	Nor	
Ch3	Nor	Ch4	Nor	
Ch5	Rev	Ch6	Nor	
Ch7	Rev	Ch8	Nor	
Ch9	Nor	Ch10	Nor	

Setup:

To change between normal and reverse touch the box to the right side of the desired channel.

Nor=Normal, Rev=Reverse.

Select the **【Back】** icon to save and return to the previous menu.

End points

The end points function changes the range of movement available to a channel. This can be used to limit the tilt of the Swift, therefore it is easier to control. The left box is the low end point, the right box is the high end point, marked below as low end point being blue and red being the high end point.

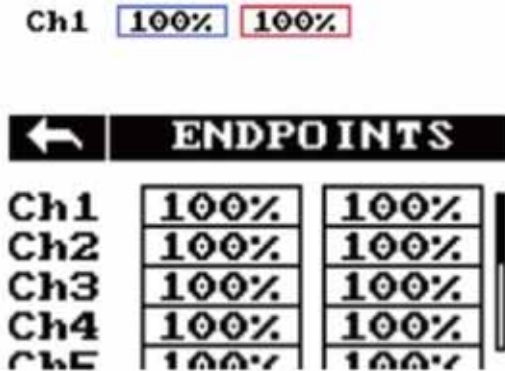

Setting method:

- 1.Touch the low or high end points box.
- 2.Touch the desired digit to be changed, then use the onscreen up and down arrows to change it's value.
- 3.Select [✓] to confirm the value, or choose [X] to quit the edit menu.
- 4.Select [back] to save and back to the previous menu.

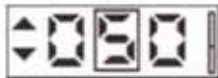

output mode

This function can select between the two output modes of the receiver, PWM mode and PPM mode. Select the applicable output mode according to requirements. The black dot icon indicates the currently selected mode.

Below graphic

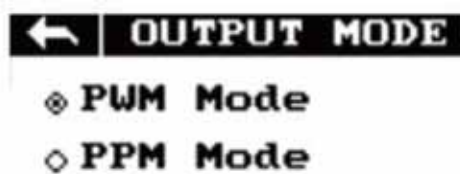

Select [back] to save and return to the previous menu.

10.2 OSD information

A video receiver is required to display the OSD information.

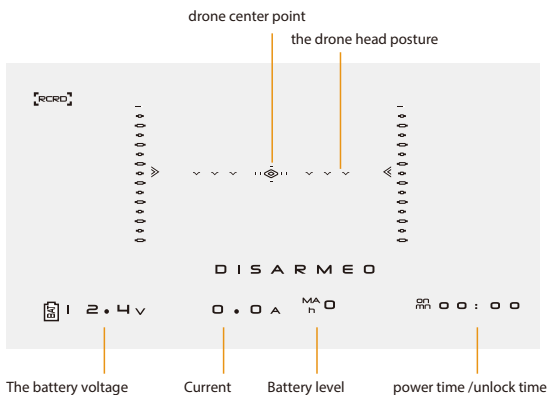

10.3 Video transmitter channel selection

There are 40 channels available.

Select the best video quality based on your screen.

Caution: Transmitter channel and video receiver channel correspond on a “one to one” system of transmission and reception.

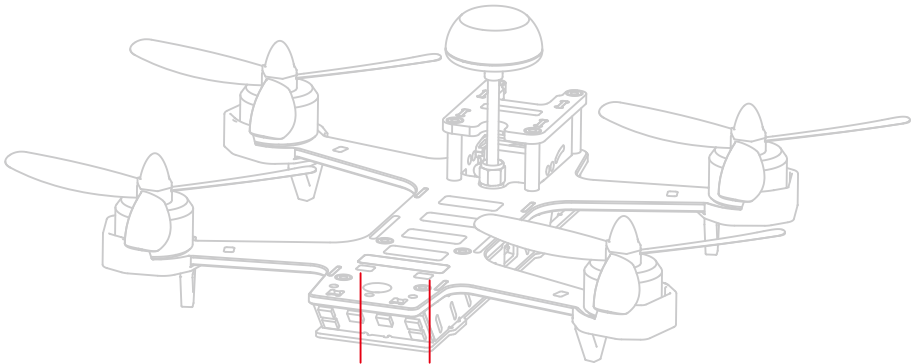

display window



Adjustment button

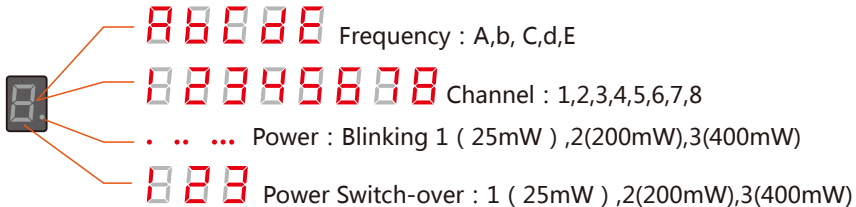

Tuning Channels

Once powering up the drone system, the current frequency will initially be displayed on the LED display, followed by the current channel, at-sight power is identified by blinking sequence of the red dot in the lower right corner. (Blinking sequence: once represents 25mW, twice represents 200mW, triple represents 400mW.)

Example: To set up channel E5

1. Long press the button for 3s and then release, the system enables the selection of a frequency from A B C D E circular fashion. To select channel E, short press the button to choose channel E1. Now, the system will circularly indicate frequency "E" & channel "1" without any operation.
2. In order to get E5, please short press the button 4 times continuously. When the system circularly indicates frequency "E" & channel "5", long press the button for 2s to confirm the selection, then release the button.

Note: The red dot in the lower right corner will blink once to confirm a successful set-up.

After completing above steps, the frequency "E" will be showed in the system first, and channel "5" follows next, and the number of blinks of the red dot stands for the current power selected.

Power selection

1. Long press the button for 5s to enter into "Power switch-over" mode.

The system will show the current power level, the number blinks slowly.

2. To enable the change of power level, short press the button once to select the desired power level from the following options: 1=(25mW) - 2=(200mW) 3=(400mW), the corresponding number will blink indicating the power level.

3. After selecting the desired power level, long press the button for 2s to confirm the selection and quit the "Power switch-over" mode, the red dot will flash once to indicate the successful set-up.

4. After releasing the button, the system will firstly indicate the expected Frequency, then comes with channel, finally the number of flashes of the red dot represents the selected Power.

10.4 Main Board Connection Diagram

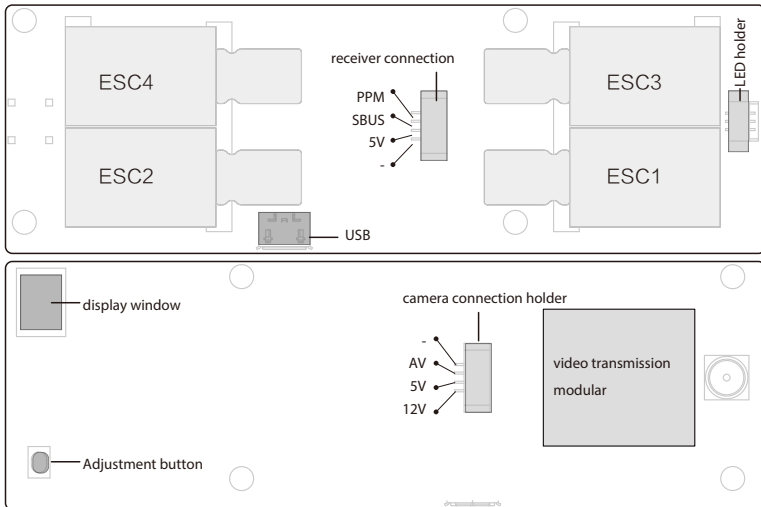

Connection Diagram - Brushless ESC and brushless motors

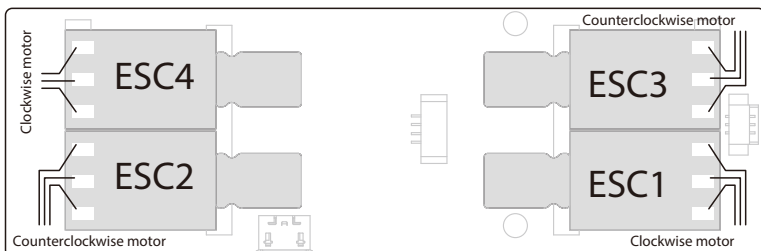

10.5 Flight controller upgrade method

OSD adjustment method

Move the 2 joysticks to their top locations in opposite direction to setting PID,

Right stick to selects the item.

Use the left stick to adjust the value (pull right to increase the value and pull left to decrease the value)

Adjustment method of the flight controller and ESC's - via USB

Please refer to the official website of F3 (<http://cleanflight.com/>)

The ESCs and flight controller can both be adjusted via USB

Please refer to the official website of F3 (<http://cleanflight.com/>) for adjustment to the flight controller.

Please download and install the Cleanflight in Google apps to adjust the flight controller.

To adjust the ESCs, please download the application and documents at swellpro.com.

Please Note: The power should be on when adjusting the ESCs.

10.6 LED indicator setting

Factory default setting (the rear toward operator)

The green indicators stay on solid after powering up the drone.

Moving the direction joystick to the left, the left yellow indicator lights turn on.

Moving the direction joystick to the right, the right yellow indicator lights turn on.

Moving the direction joystick down, the yellow indicator lights on the left and right are both on and blink.

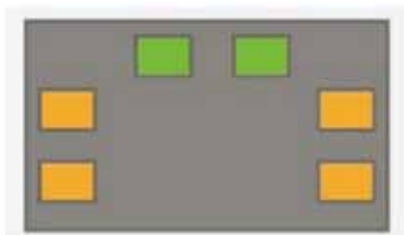

To customize the LED light colors:

For Detailed adjustment methods, please refer to the official website of the F3 Controller - (<http://cleanflight.com/>)

11. Instructions for balance charger

General specification of the balance charger

Input voltage: AC100-240V

Charging power : 35W

Support battery: LiPo 2-4S

Balance current: 400mA

Charging current: $3A \pm 10\%$

Operation instructions :

1. Insert the AC power cord into changer and connect to a suitable 100-240V AC socket
2. Connect the battery to the balance charger, after the LED indicator lights stay on for 1 second.
3. Charging is complete when all the indicator lights stay on solid.

Charging connection diagram

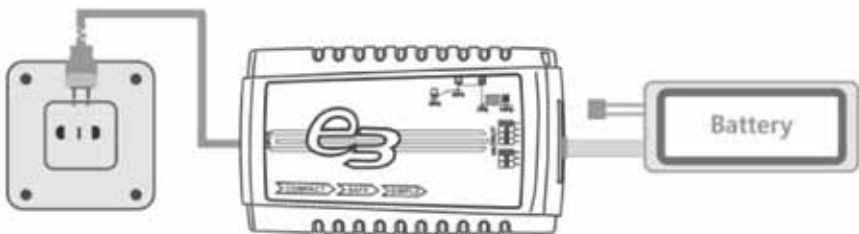

Attention :

1. Please make sure the correct battery type is used, always power on the charger before connecting a battery, or damage to the hanger and battery can result.
2. During the charging process, if the 4 LEDs keep blinking, that indicates an ERROR, stop charging and establish the reason for the error.

Notice

- Do not leave the battery and charger unattended when charging.
- Place the charger in a dry and well ventilated place during charging.
- Do not charge waste , damaged or wet batteries.
- Do not charge different types of battery packs.
- Do not allow children under 15 years to use the charger, to avoid accidents.
- Do not charge in overheated or overcooled places, avoid placing the charger in direct sunlight.
- Do not charge if the battery connecting wires are damaged or short-circuited.
- Do not connect the 12V car battery when the car is moving.
- Do not disassemble or use the broken charger.
- Do not cover the charger cooling fan .

12. Installation of Camera Mount

1. Using GoPro HERO 3,4 and 5 cameras.

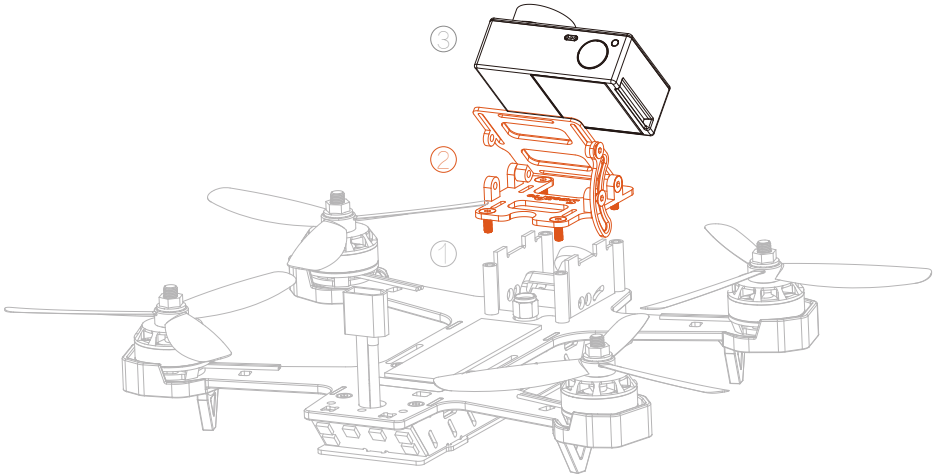

- ① Loosen the screws and release the frame on the top of the camera.
- ② Fix the "G" mount on the top, with screws provided. Please ensure it is in the right direction.
- ③ Fasten the camera with the strap, loosen the side screws, adjust the camera angle to your own preferred angle, and then tighten the screw.

1. Runcam camera mount (Such as: GoPro HERO Session)

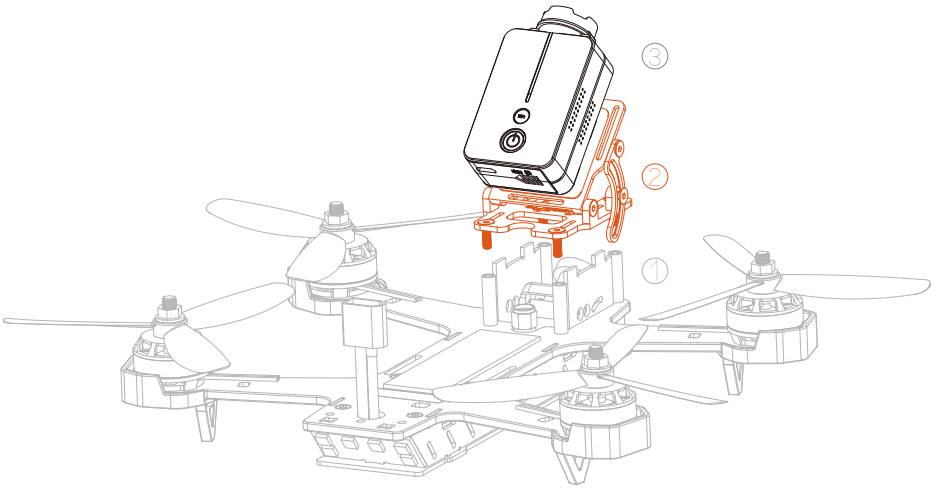

- ① Loosen the screws and release the frame on the top of the camera
- ② Fix the "R" mount on the top with screws in the right direction
Fasten the camera with the strap, loosen the side screws, adjust
- ③ the camera angle to your own preferred angle, and then tighten the screw.

Please Note:

"G" mount is for GoPro HERO 3,4,5 camera.

"R" mount is for Runcam cameras, (Such as: GoPro HERO Session).

Please select the right model of mount at the time of purchasing.



SwellPro

SWELLPRO TECHNOLOGY Co., LTD

TEL: 0755-82266175

Email: info@swellpro.com

Address: D15.shengang Flower Center , Shohe West Road, ShenZhen, China 51800

V 1.1

2017.02.20