

DDR Module Connectors

AP_DQ0	BA15	AP_M_DQ0	UT	AP_A0
AP_DQ1	BA15	AP_M_DQ0	AP_M_A0	AP_A1
AP_DQ2	AY14	AP_M_DQ1	AP_M_A1	AP_A2
AP_DQ3	AW13	AP_M_DQ2	AP_M_A2	AP_A3
AP_DQ4	AY10	AP_M_DQ3	AP_M_A3	AP_A4
AP_DQ5	AW9	AP_M_DQ4	AP_M_A4	AP_A5
AP_DQ6	BA9	AP_M_DQ5	AP_M_A5	AP_A6
AP_DQ7	AW8	AP_M_DQ6	AP_M_A6	AP_A7
AP_DQ8	BA7	AP_M_DQ7	AP_M_A7	AP_A8
AP_DQ9	AW7	AP_M_DQ8	AP_M_A8	AP_A9
AP_DQ10	AV6	AP_M_DQ9	AP_M_A9	AP_A10
AP_DQ11	AV8	AP_M_DQ10	AP_M_A10	AP_A11
AP_DQ12	AW5	AP_M_DQ11	AP_M_A11	AP_A12
AP_DQ13	AW3	AP_M_DQ12	AP_M_A12	AP_A13
AP_DQ14	AV2	AP_M_DQ13	AP_M_A13	AP_A14
AP_DQ15	BA2	AP_M_DQ14	AP_M_A14	AP_A15
AP_DQ16	AW1	AP_M_DQ15	AP_M_A15	AP_A16
AP_DQ17	AV1	AP_M_DQ16	AP_M_A16	AP_A17
AP_DQ18	AW2	AP_M_DQ17	AP_M_A17	AP_A18
AP_DQ19	AV1	AP_M_DQ18	AP_M_A18	AP_A19
AP_DQ20	AW1	AP_M_DQ19	AP_M_A19	AP_A20
AP_DQ21	AV2	AP_M_DQ20	AP_M_A20	AP_A21
AP_DQ22	AW3	AP_M_DQ21	AP_M_A21	AP_A22
AP_DQ23	AV3	AP_M_DQ22	AP_M_A22	AP_A23
AP_DQ24	AW4	AP_M_DQ23	AP_M_A23	AP_A24
AP_DQ25	AV5	AP_M_DQ24	AP_M_A24	AP_A25
AP_DQ26	AW6	AP_M_DQ25	AP_M_A25	AP_A26
AP_DQ27	AV7	AP_M_DQ26	AP_M_A26	AP_A27
AP_DQ28	AW8	AP_M_DQ27	AP_M_A27	AP_A28
AP_DQ29	AV8	AP_M_DQ28	AP_M_A28	AP_A29
AP_DQ30	AW9	AP_M_DQ29	AP_M_A29	AP_A30
AP_DQ31	AV9	AP_M_DQ30	AP_M_A30	AP_A31
AP_DQ32	AW10	AP_M_DQ31	AP_M_A31	AP_A32
AP_DQ33	AV10	AP_M_DQ32	AP_M_A32	AP_A33
AP_DQ34	AW11	AP_M_DQ33	AP_M_A33	AP_A34
AP_DQ35	AV11	AP_M_DQ34	AP_M_A34	AP_A35
AP_DQ36	AW12	AP_M_DQ35	AP_M_A35	AP_A36
AP_DQ37	AV12	AP_M_DQ36	AP_M_A36	AP_A37
AP_DQ38	AW13	AP_M_DQ37	AP_M_A37	AP_A38
AP_DQ39	AV13	AP_M_DQ38	AP_M_A38	AP_A39
AP_DQ40	AW14	AP_M_DQ39	AP_M_A39	AP_A40
AP_DQ41	AV14	AP_M_DQ40	AP_M_A40	AP_A41
AP_DQ42	AW15	AP_M_DQ41	AP_M_A41	AP_A42
AP_DQ43	AV15	AP_M_DQ42	AP_M_A42	AP_A43
AP_DQ44	AW16	AP_M_DQ43	AP_M_A43	AP_A44
AP_DQ45	AV16	AP_M_DQ44	AP_M_A44	AP_A45
AP_DQ46	AW17	AP_M_DQ45	AP_M_A45	AP_A46
AP_DQ47	AV17	AP_M_DQ46	AP_M_A46	AP_A47
AP_DQ48	AW18	AP_M_DQ47	AP_M_A47	AP_A48
AP_DQ49	AV18	AP_M_DQ48	AP_M_A48	AP_A49
AP_DQ50	AW19	AP_M_DQ49	AP_M_A49	AP_A50
AP_DQ51	AV19	AP_M_DQ50	AP_M_A50	AP_A51
AP_DQ52	AW20	AP_M_DQ51	AP_M_A51	AP_A52
AP_DQ53	AV20	AP_M_DQ52	AP_M_A52	AP_A53
AP_DQ54	AW21	AP_M_DQ53	AP_M_A53	AP_A54
AP_DQ55	AV21	AP_M_DQ54	AP_M_A54	AP_A55
AP_DQ56	AW22	AP_M_DQ55	AP_M_A55	AP_A56
AP_DQ57	AV22	AP_M_DQ56	AP_M_A56	AP_A57
AP_DQ58	AW23	AP_M_DQ57	AP_M_A57	AP_A58
AP_DQ59	AV23	AP_M_DQ58	AP_M_A58	AP_A59
AP_DQ60	AW24	AP_M_DQ59	AP_M_A59	AP_A60
AP_DQ61	AV24	AP_M_DQ60	AP_M_A60	AP_A61
AP_DQ62	AW25	AP_M_DQ61	AP_M_A61	AP_A62
AP_DQ63	AV25	AP_M_DQ62	AP_M_A62	AP_A63
AP_DQ64	AW26	AP_M_DQ63	AP_M_A63	AP_A64
AP_DQ65	AV26	AP_M_DQ64	AP_M_A64	AP_A65
AP_DQ66	AW27	AP_M_DQ65	AP_M_A65	AP_A66
AP_DQ67	AV27	AP_M_DQ66	AP_M_A66	AP_A67
AP_DQ68	AW28	AP_M_DQ67	AP_M_A67	AP_A68
AP_DQ69	AV28	AP_M_DQ68	AP_M_A68	AP_A69
AP_DQ70	AW29	AP_M_DQ69	AP_M_A69	AP_A70
AP_DQ71	AV29	AP_M_DQ70	AP_M_A70	AP_A71
AP_DQ72	AW30	AP_M_DQ71	AP_M_A71	AP_A72
AP_DQ73	AV30	AP_M_DQ72	AP_M_A72	AP_A73
AP_DQ74	AW31	AP_M_DQ73	AP_M_A73	AP_A74
AP_DQ75	AV31	AP_M_DQ74	AP_M_A74	AP_A75
AP_DQ76	AW32	AP_M_DQ75	AP_M_A75	AP_A76
AP_DQ77	AV32	AP_M_DQ76	AP_M_A76	AP_A77
AP_DQ78	AW33	AP_M_DQ77	AP_M_A77	AP_A78
AP_DQ79	AV33	AP_M_DQ78	AP_M_A78	AP_A79
AP_DQ80	AW34	AP_M_DQ79	AP_M_A79	AP_A80
AP_DQ81	AV34	AP_M_DQ80	AP_M_A80	AP_A81
AP_DQ82	AW35	AP_M_DQ81	AP_M_A81	AP_A82
AP_DQ83	AV35	AP_M_DQ82	AP_M_A82	AP_A83
AP_DQ84	AW36	AP_M_DQ83	AP_M_A83	AP_A84
AP_DQ85	AV36	AP_M_DQ84	AP_M_A84	AP_A85
AP_DQ86	AW37	AP_M_DQ85	AP_M_A85	AP_A86
AP_DQ87	AV37	AP_M_DQ86	AP_M_A86	AP_A87
AP_DQ88	AW38	AP_M_DQ87	AP_M_A87	AP_A88
AP_DQ89	AV38	AP_M_DQ88	AP_M_A88	AP_A89
AP_DQ90	AW39	AP_M_DQ89	AP_M_A89	AP_A90
AP_DQ91	AV39	AP_M_DQ90	AP_M_A90	AP_A91
AP_DQ92	AW40	AP_M_DQ91	AP_M_A91	AP_A92
AP_DQ93	AV40	AP_M_DQ92	AP_M_A92	AP_A93
AP_DQ94	AW41	AP_M_DQ93	AP_M_A93	AP_A94
AP_DQ95	AV41	AP_M_DQ94	AP_M_A94	AP_A95
AP_DQ96	AW42	AP_M_DQ95	AP_M_A95	AP_A96
AP_DQ97	AV42	AP_M_DQ96	AP_M_A96	AP_A97
AP_DQ98	AW43	AP_M_DQ97	AP_M_A97	AP_A98
AP_DQ99	AV43	AP_M_DQ98	AP_M_A98	AP_A99
AP_DQ100	AW44	AP_M_DQ99	AP_M_A99	AP_A100
AP_DQ101	AV44	AP_M_DQ100	AP_M_A100	AP_A101
AP_DQ102	AW45	AP_M_DQ101	AP_M_A101	AP_A102
AP_DQ103	AV45	AP_M_DQ102	AP_M_A102	AP_A103
AP_DQ104	AW46	AP_M_DQ103	AP_M_A103	AP_A104
AP_DQ105	AV46	AP_M_DQ104	AP_M_A104	AP_A105
AP_DQ106	AW47	AP_M_DQ105	AP_M_A105	AP_A106
AP_DQ107	AV47	AP_M_DQ106	AP_M_A106	AP_A107
AP_DQ108	AW48	AP_M_DQ107	AP_M_A107	AP_A108
AP_DQ109	AV48	AP_M_DQ108	AP_M_A108	AP_A109
AP_DQ110	AW49	AP_M_DQ109	AP_M_A109	AP_A110
AP_DQ111	AV49	AP_M_DQ110	AP_M_A110	AP_A111
AP_DQ112	AW50	AP_M_DQ111	AP_M_A111	AP_A112
AP_DQ113	AV50	AP_M_DQ112	AP_M_A112	AP_A113
AP_DQ114	AW51	AP_M_DQ113	AP_M_A113	AP_A114
AP_DQ115	AV51	AP_M_DQ114	AP_M_A114	AP_A115
AP_DQ116	AW52	AP_M_DQ115	AP_M_A115	AP_A116
AP_DQ117	AV52	AP_M_DQ116	AP_M_A116	AP_A117
AP_DQ118	AW53	AP_M_DQ117	AP_M_A117	AP_A118
AP_DQ119	AV53	AP_M_DQ118	AP_M_A118	AP_A119
AP_DQ120	AW54	AP_M_DQ119	AP_M_A119	AP_A120
AP_DQ121	AV54	AP_M_DQ120	AP_M_A120	AP_A121
AP_DQ122	AW55	AP_M_DQ121	AP_M_A121	AP_A122
AP_DQ123	AV55	AP_M_DQ122	AP_M_A122	AP_A123
AP_DQ124	AW56	AP_M_DQ123	AP_M_A123	AP_A124
AP_DQ125	AV56	AP_M_DQ124	AP_M_A124	AP_A125
AP_DQ126	AW57	AP_M_DQ125	AP_M_A125	AP_A126
AP_DQ127	AV57	AP_M_DQ126	AP_M_A126	AP_A127
AP_DQ128	AW58	AP_M_DQ127	AP_M_A127	AP_A128
AP_DQ129	AV58	AP_M_DQ128	AP_M_A128	AP_A129
AP_DQ130	AW59	AP_M_DQ129	AP_M_A129	AP_A130
AP_DQ131	AV59	AP_M_DQ130	AP_M_A130	AP_A131
AP_DQ132	AW60	AP_M_DQ131	AP_M_A131	AP_A132
AP_DQ133	AV60	AP_M_DQ132	AP_M_A132	AP_A133
AP_DQ134	AW61	AP_M_DQ133	AP_M_A133	AP_A134
AP_DQ135	AV61	AP_M_DQ134	AP_M_A134	AP_A135
AP_DQ136	AW62	AP_M_DQ135	AP_M_A135	AP_A136
AP_DQ137	AV62	AP_M_DQ136	AP_M_A136	AP_A137
AP_DQ138	AW63	AP_M_DQ137	AP_M_A137	AP_A138
AP_DQ139	AV63	AP_M_DQ138	AP_M_A138	AP_A139
AP_DQ140	AW64	AP_M_DQ139	AP_M_A139	AP_A140
AP_DQ141	AV64	AP_M_DQ140	AP_M_A140	AP_A141
AP_DQ142	AW65	AP_M_DQ141	AP_M_A141	AP_A142
AP_DQ143	AV65	AP_M_DQ142	AP_M_A142	AP_A143
AP_DQ144	AW66	AP_M_DQ143	AP_M_A143	AP_A144
AP_DQ145	AV66	AP_M_DQ144	AP_M_A144	AP_A145
AP_DQ146	AW67	AP_M_DQ145	AP_M_A145	AP_A146
AP_DQ147	AV67	AP_M_DQ146	AP_M_A146	AP_A147
AP_DQ148	AW68	AP_M_DQ147	AP_M_A147	AP_A148
AP_DQ149	AV68	AP_M_DQ148	AP_M_A148	AP_A149
AP_DQ150	AW69	AP_M_DQ149	AP_M_A149	AP_A150
AP_DQ151	AV69	AP_M_DQ150	AP_M_A150	AP_A151
AP_DQ152	AW70	AP_M_DQ151	AP_M_A151	AP_A152
AP_DQ153	AV70	AP_M_DQ152	AP_M_A152	AP_A153
AP_DQ154	AW71	AP_M_DQ153	AP_M_A153	AP_A154
AP_DQ155	AV71	AP_M_DQ154	AP_M_A154	AP_A155
AP_DQ156	AW72	AP_M_DQ155	AP_M_A155	AP_A156
AP_DQ157	AV72	AP_M_DQ156	AP_M_A156	AP_A157
AP_DQ158	AW73	AP_M_DQ157	AP_M_A157	AP_A158
AP_DQ159	AV73	AP_M_DQ158	AP_M_A158	AP_A159
AP_DQ160	AW74	AP_M_DQ159	AP_M_A159	AP_A160
AP_DQ161	AV74	AP_M_DQ160	AP_M_A160	AP_A161
AP_DQ162	AW75	AP_M_DQ161	AP_M_A161	AP_A162
AP_DQ163	AV75	AP_M_DQ162	AP_M_A162	AP_A163
AP_DQ164	AW76	AP_M_DQ163	AP_M_A163	AP_A164
AP_DQ165	AV76	AP_M_DQ164	AP_M_A164	AP_A165
AP_DQ166	AW77	AP_M_DQ165	AP_M_A165	AP_A166
AP_DQ167	AV77	AP_M_DQ166	AP_M_A166	AP_A167
AP_DQ168	AW78	AP_M_DQ167	AP_M_A167	AP_A168
AP_DQ169	AV78	AP_M_DQ168	AP_M_A168	AP_A169
AP_DQ170	AW79	AP_M_DQ169	AP_M_A169	AP_A170
AP_DQ171	AV79	AP_M_DQ170	AP_M_A170	AP_A171
AP_DQ172	AW80	AP_M_DQ171	AP_M_A171	AP_A172
AP_DQ173	AV80	AP_M_DQ172	AP_M_A172	AP_A173
AP_DQ174	AW81	AP_M_DQ173	AP_M_A173	AP_A174
AP_DQ175	AV81	AP_M_DQ174	AP_M_A174	AP_A175
AP_DQ176	AW82	AP_M_DQ175	AP_M_A175	AP_A176
AP_DQ177	AV82	AP_M_DQ176	AP_M_A176	AP_A177
AP_DQ178	AW83	AP_M_DQ177	AP_M_A177	AP_A178
AP_DQ179	AV83	AP_M_DQ178	AP_M_A178	AP_A179
AP_DQ180	AW84	AP_M_DQ179	AP_M_A179	AP_A180
AP_DQ181	AV84	AP_M_DQ180	AP_M_A180	AP_A181
AP_DQ182	AW85	AP_M_DQ181	AP_M_A181	AP_A182
AP_DQ183	AV85	AP_M_DQ182	AP_M_A182	AP_A183
AP_DQ184	AW86	AP_M_DQ183	AP_M_A183	AP_A184
AP_DQ185	AV86	AP_M_DQ184	AP_M_A184	AP_A185
AP_DQ186	AW87	AP_M_DQ185	AP_M_A185	AP_A186
AP_DQ187	AV87	AP_M_DQ186	AP_M_A186	AP_A187
AP_DQ188	AW88	AP_M_DQ187	AP_M_A187	AP_A188
AP_DQ189	AV88	AP_M_DQ188	AP_M_A188	AP_A189
AP_DQ190	AW89	AP_M_DQ189	AP_M_A189	AP_A190
AP_DQ191	AV89	AP_M_DQ190	AP_M_A190	AP_A191
AP_DQ192	AW90	AP_M_DQ191	AP_M_A191	AP_A192
AP_DQ193	AV90	AP_M_DQ192	AP_M_A192	AP_A193
AP_DQ194	AW91	AP_M_DQ193	AP_M_A193	AP_A194
AP_DQ195	AV91	AP_M_DQ194	AP_M_A194	AP_A195
AP_DQ196	AW92	AP_M_DQ195	AP_M_A195	AP_A196
AP_DQ197	AV92	AP_M_DQ196	AP_M_A196	AP_A197
AP_DQ198	AW93	AP_M_DQ197	AP_M_A197	AP_A198
AP_DQ199	AV93	AP_M_DQ198		

Processor SERDESes

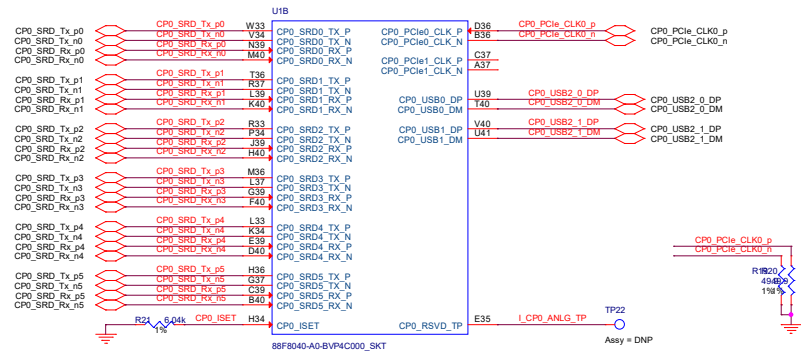

I2C Mux to SFP and dual SFP+ connectors

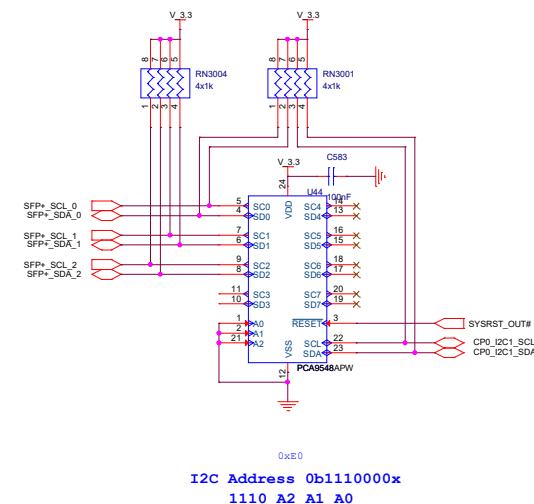

eMMC (bootable)

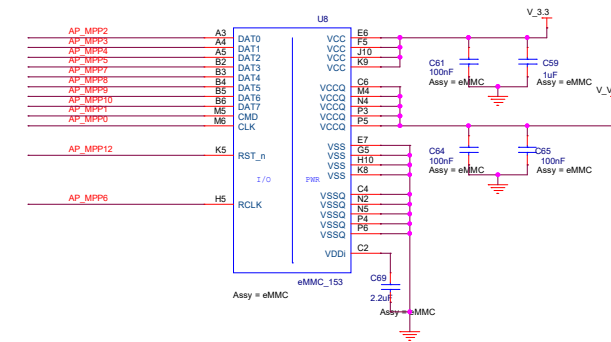

micro SD connector (bootable)

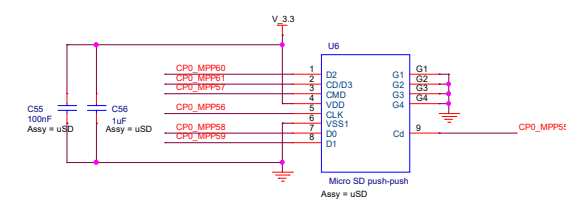

SPI Flash (bootable)

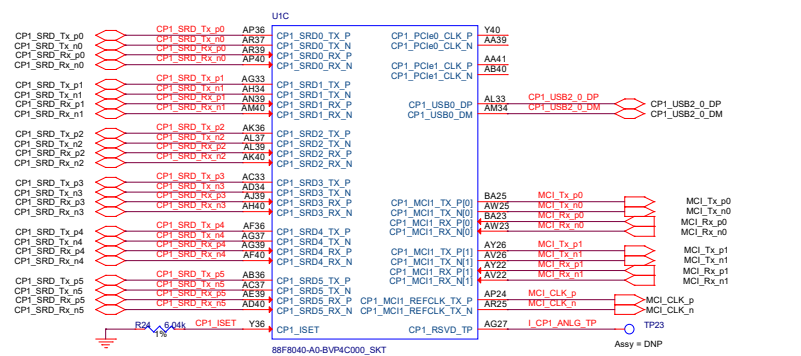
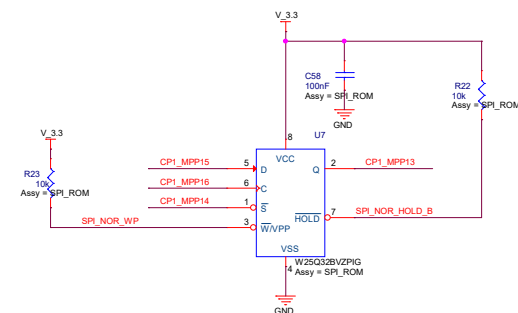

UART Headers

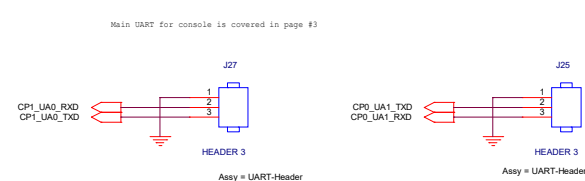

JTAG Connector

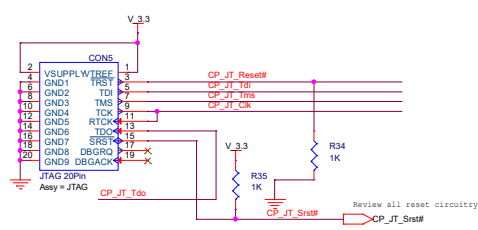

Misc reset straps

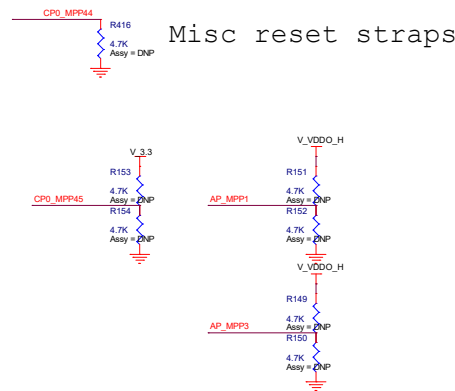

Processor GPIOs, JTAG and Crystals

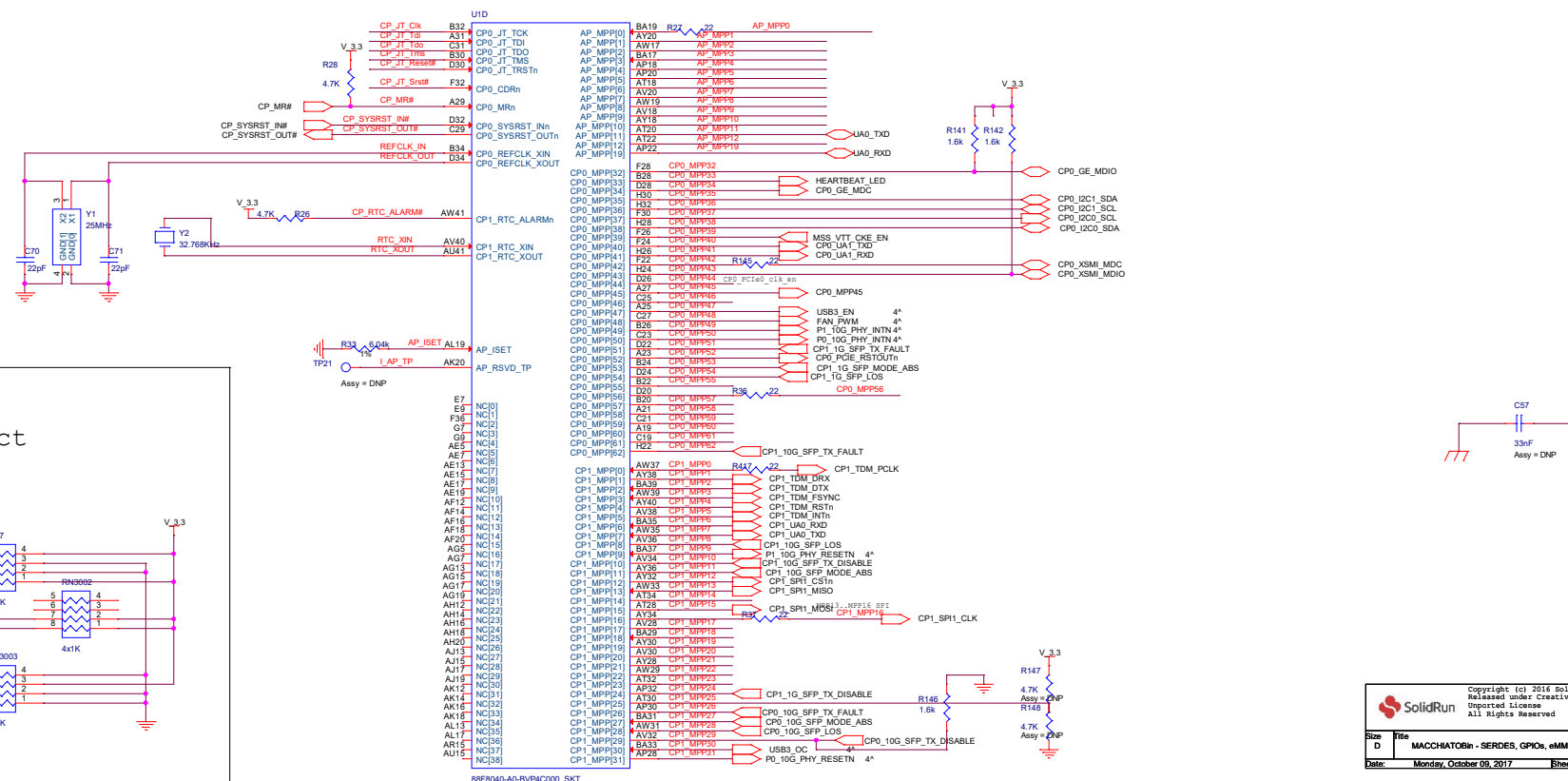

Reset logic

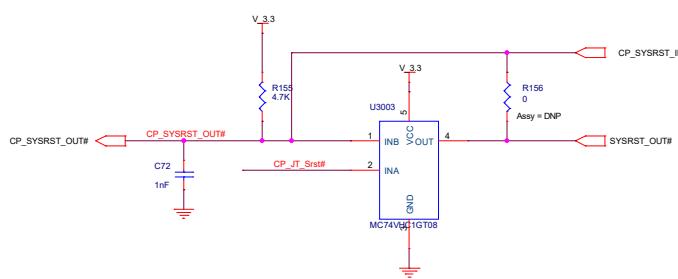

Boot and frequency select

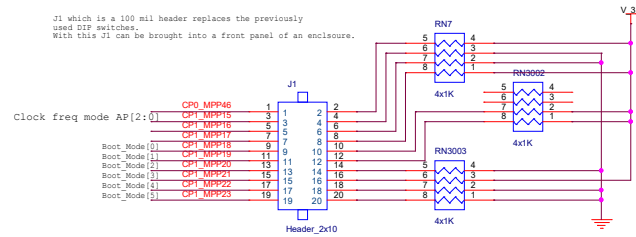

1Gbps Ethernet copper

